

ORDINANCE NO. 201, 2025  
OF THE COUNCIL OF THE CITY OF FORT COLLINS  
AMENDING CHAPTER 9, ARTICLE I OF THE CODE OF THE CITY OF FORT  
COLLINS FOR THE PURPOSE OF UPDATING LOCAL AMENDMENTS TO THE 2024  
INTERNATIONAL FIRE CODE

A. Since 1924, the City has reviewed, amended and adopted the latest nationally recognized building standards available for the times.

B. Upon recommendation of City staff, the City Council has determined that it is in the best interests of the City to align eleven interconnected basic construction codes under one publication year.

C. The eleven interconnected basic construction codes are the *International Building Code*, *International Residential Code*, *International Mechanical Code*, *International Fuel Gas Code*, *International Energy Conservation Code*, *International Property Maintenance Code*, *International Swimming Pool and Spa Code*, *International Existing Building Code*, *International Plumbing Code*, *International Fire Code*, and the *International Wildland-Urban Interface Code* to the extent adopted by the *Colorado Wildfire Resiliency Code*.

D. On June 17, 2025, City Council adopted Ordinance No. 051, 2025, and the *2024 International Fire Code* with local amendments.

E. The *2024 International Fire Code* and local amendments were initially adopted separately from the other ten interconnected basic construction codes, which were still undergoing review.

F. Now that the other ten interconnected basic construction codes have been reviewed and are ready for adoption concurrently with this Ordinance, the City's local amendments to the *2024 International Fire Code* require some corrections to align with the other ten codes.

G. The City Council has determined that it is in the best interest of the health, safety and welfare of the City and its residents that the local amendments to the *2024 International Fire Code* be updated, as set forth in this Ordinance.

In light of the foregoing recitals, which the Council hereby makes and adopts as determinations and findings, BE IT ORDAINED BY THE COUNCIL OF THE CITY OF FORT COLLINS as follows:

Section 1. Section 9-2 of the Code of the City of Fort Collins is hereby amended as follows:

**Sec. 9-2. Amendments and deletions to the 2024 International Fire Code.**

The 2024 *International Fire Code* adopted in §9-1 is amended to read as follows:

...

6. **Section 202 General Definitions** is amended to modify, or add, in alphabetical order, the following definitions:

...

...

32. A new **Section 505.1.7 Interior wayfinding** is added to read as follows:

**505.1.7 Interior wayfinding.** *Approved* wayfinding signage shall be posted in conspicuous locations within buildings to provide clear direction to locate any suite, apartment, or unit within the building. Interior wayfinding signage shall be a minimum of one inch in height with a minimum 1/4 inch stroke. Directory type signage intended to provide general listings or wayfinding to groups of occupants shall not be subject to the dimensional requirements of this section.

...

37. **Section 507.5.1 Where required** is amended to read as follows:

**507.5.1 Where required.** Where the furthest portion of a facility or building or portion thereof hereafter constructed or moved into or within the jurisdiction is more than 300 feet (91 m) from a hydrant on a fire apparatus access road, as measured by an *approved* route around the exterior of the facility or building, on-site fire hydrants and mains shall be provided where required by the *fire code official*.

**Exceptions:**

1. For Group R-3, one- and two-family dwellings, and Group U occupancies, the distance requirement shall be 400 feet (121 m).
2. For buildings equipped throughout with an *approved automatic sprinkler system* installed in accordance with Section 903.3.1.1 or 903.3.1.2, the *fire code official* is authorized to extend the distance requirement up to 600 feet (183 m).

- 37.1 **Section 510.1 Emergency responder communications enhancement systems in new buildings** is amended to read as follows:

**510.1 Emergency responder communications enhancement systems**

**in new buildings.** *Approved* in-building emergency responder communications enhancement system (ERCES) for emergency responders shall be provided in all new buildings. In-building ERCES within the building shall be based on the existing coverage levels of the public safety communications systems utilized by the jurisdiction, measured at the exterior of the building. The ERCES, where required, shall be of a type determined by the *fire code official* and the *frequency license holder(s)*. This section shall not require improvement of the existing public safety communications systems.

**Exceptions:**

...

4. In all buildings not exceeding 10,000 square feet and any Type V construction building not exceeding 15,000 square feet.

...

52. **Section 903.2.10 Group S-2 parking garages** is amended to read as follows:

**903.2.10 Group S-2 parking garages.** *An automatic sprinkler system* shall be provided throughout all buildings containing a Group S-2 occupancy where any of the following conditions exists:

1. Where a Group S-2 fire area exceeds 5,000 square feet (464.5 m<sup>2</sup>).

...

...

54. **Section 903.3.1.2.3 Attics** is amended to add subsection 5 and its Exceptions to read as follows:

5. In buildings containing dwelling or sleeping units, the automatic fire sprinkler system shall be designed and installed in accordance with NFPA 13, regardless of the fire sprinkler installation standard allowed for other portions of the building.

**Exceptions:**

1. Buildings that do not contain more than 6 individual dwelling units or sleeping units and the units are separated from each other with a 1-hour fire barrier.
2. Buildings that do not contain more than 12 individual dwelling units or sleeping units and is divided into no more than 6 individual dwellings units (complying with number 1 above) by a minimum 2-hour fire barrier to the roof deck.
3. Buildings containing only Group R-3 occupancy.

...

- 59. **Section 907.5.2.1.3.2 Smoke alarm signal in sleeping rooms** is amended to read as follows:

**907.5.2.1.3.2 Smoke alarm signal in sleeping rooms.** In sleeping rooms of Group R-1, R-2 and I-1 occupancies that are required by Section 907.2.8 or 907.2.9 to have a *fire alarm system*, the audible alarm signal activated by single- or multiple-station smoke alarms in the *dwelling unit* or *sleeping unit* shall be a 520-Hz signal complying with NFPA 72.

Where a sleeping room smoke alarm is unable to produce a 520-Hz alarm signal, the 520-Hz alarm signal shall be provided by a *listed* notification appliance or an alternative means approved by the *fire code official*.

...

- 81. A new **CHAPTER 68 APPENDIX ADOPTION STATUS** is added to read as follows:

APPENDIX	TITLE	STATUS
A	Board of Appeals	Not Adopted
...	...	...

...

- 85. **APPENDIX D FIRE APPARATUS ACCESS ROADS** is deleted in its entirety and replaced with the following:

...

**FIGURE D103.1 - DEAD END FIRE APPARATUS ACCESS ROAD TURNAROUND**

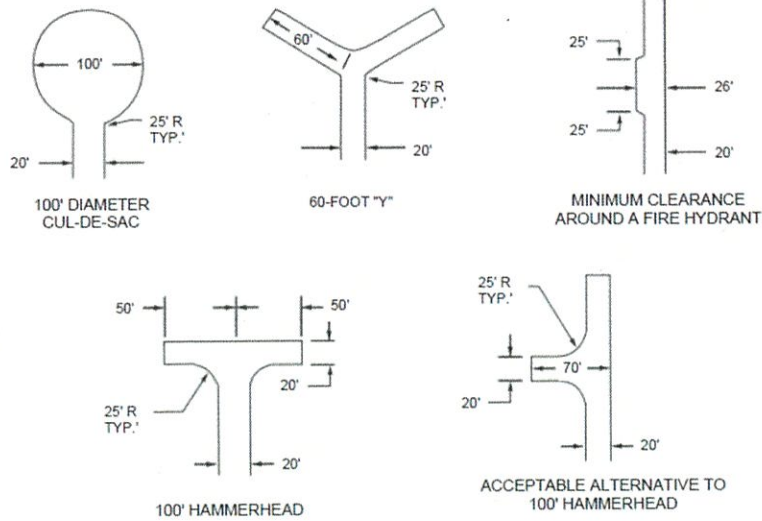

...

**D103.4 Dead Ends.** Dead-end fire apparatus access roads in excess of 150 feet (46 m) shall be provided with width and turnaround provisions in accordance with Table D103.4.

...

**D103.6 Signs.** Where required by the *fire code official*, fire apparatus access roads shall be marked with permanent NO PARKING-FIRE LANE signs complying with Figure D 103.6 or other *approved* sign. Signs shall have a minimum dimension of 12 inches (305 mm) wide by 18 inches (457 mm) high and have red letters on a white reflective background. Signs shall be posted on one or both sides of the fire apparatus road as required by Sections D103.8.1 or D103.8.2.

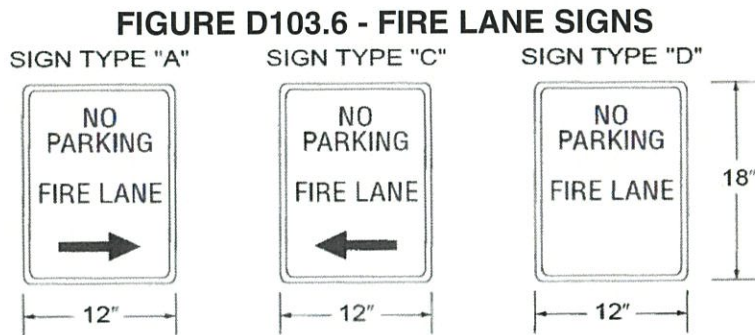

**D103.6.1 Roads 20 to 26 feet in width.** *Fire lanes* signs as specified in D103.6 shall be posted on both sides of fire apparatus access roads that are 20 to 26 feet wide (6096 to 7925 mm).

**D103.6.2 Roads more than 26 feet in width.** *Fire lanes* signs as specified in D103.6 shall be posted on one side of the fire apparatus access roads more than 26 feet wide (7925 mm) and less than 32 feet wide (9754 mm).

...

...

Section 2. Chapter 10 of the *2024 International Fire Code*, entitled “MEANS OF EGRESS,” along with all its local amendments contained in paragraphs 61 through 67 of Section 9-2 of the Code of the City of Fort Collins are hereby deleted in their entirety and replaced with the following local amendment, with all subsequent paragraph numbers renumbered:

61. **CHAPTER 10 MEANS OF EGRESS** is deleted in its entirety and replaced with the following:

**CHAPTER 10 MEANS OF EGRESS**

**SECTION 1001 ADMINISTRATION**

**1001.1 General.** Any buildings or portions thereof regulated by this code shall be provided with a means of egress system as required by Chapter 10 of the adopted *International Building Code*.

Section 3. The codifier of the Code of the City of Fort Collins is hereby directed to amend all existing cross references in the City Code and the Land Use Code in accordance with the provisions of this ordinance.

Section 4. The City Attorney and the City Clerk are hereby authorized to modify the formatting and to make such other amendments to this Ordinance as necessary to facilitate publication in the Fort Collins City Code; provided, however, that such modifications and amendments shall not change the substance of the Code provisions.

Section 5. Violations of the City Code provisions set forth above, on or after April 1, 2026, shall be subject to enforcement.

Introduced, considered favorably on first reading on December 2, 2025, and approved on second reading for final passage on December 16, 2025.

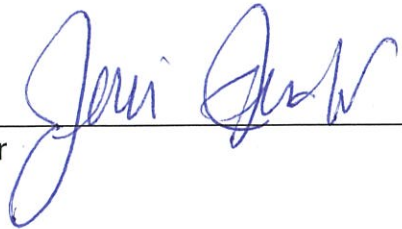
\_\_\_\_\_  
Mayor 

ATTEST:

\_\_\_\_\_  
City Clerk 



Effective Date: December 26, 2025  
Approving Attorney: Madelene Shehan

Exhibit: None