

APPENDIX P-1: - EROSION CONTROL NOTES

1. The contractor shall install erosion/sedimentation controls and tree/natural area protective fencing prior to any site preparation work (clearing, grubbing or excavation).
2. The placement of erosion/sedimentation controls shall be in accordance with the Environmental Criteria Manual and the approved Erosion and Sedimentation Control Plan. The COA ESC Plan shall be consulted and used as the basis for a TPDES required SWPPP. If a SWPPP is required, it shall be available for review by the City of Austin Environmental Inspector at all times during construction, including at the Pre-Construction meeting. The checklist below contains the basic elements that shall be reviewed for permit approval by COA EV Plan Reviewers as well as COA EV Inspectors.

— Plan sheets submitted to the City of Austin MUST show the following:

- ✓ Direction of flow during grading operations.
- ✓ Location, description, and calculations for off-site flow diversion structures.
- ✓ Areas that will not be disturbed; natural features to be preserved.
- ✓ Delineation of contributing drainage area to each proposed BMP (e.g., silt fence, sediment basin, etc.)
- ✓ Location and type of E&S BMPs for each phase of disturbance.
- ✓ Calculations for BMPs as required.
- ✓ Location and description of temporary stabilization measures.
- ✓ Location of on-site spoils, description of handling and disposal of borrow materials, and description of on-site permanent spoils disposal areas, including size, depth of fill and revegetation procedures.
- ✓ Describe sequence of construction as it pertains to ESC including the following elements:
 1. Installation sequence of controls (e.g. perimeter controls, then sediment basins, then temporary stabilization, then permanent, etc)
 2. Project phasing if required (LOC greater than 25 acres)
 3. Sequence of grading operations and notation of temporary stabilization measures to be used
 4. Schedule for converting temporary basins to permanent WQ controls
 5. schedule for removal of temporary controls
 6. Anticipated maintenance schedule for temporary controls

— Categorize each BMP under one of the following areas of BMP activity as described below:

- 3.1 Minimize disturbed area and protect natural features and soil
- 3.2 Control Stormwater flowing onto and through the project
- 3.3 Stabilize Soils
- 3.4 Protect Slopes
- 3.5 Protect Storm Drain Inlets
- 3.6 Establish Perimeter Controls and Sediment Barriers
- 3.7 Retain Sediment On-Site and Control Dewatering Practices
- 3.8 Establish Stabilized Construction Exits
- 3.9 Any Additional BMPs

— Note the location of each BMP on your site map(s).

— For any structural BMPs, you should provide design specifications and details and refer to them.

— For more information, see City of Austin Environmental Criteria Manual 1.4.

3. The Placement of tree/natural area protective fencing shall be in accordance with the City of Austin standard Notes for Tree and Natural Area Protection and the approved Grading/Tree and Natural Area Plan.
4. A pre-construction conference shall be held on-site with the contractor, design Engineer/permit applicant and Environmental Inspector after installation of the erosion/sedimentation controls and tree/natural area protection measures and prior to beginning any site preparation work. The owner or owner's representative shall notify the Planning and Development Review Department, 974-2278, at least three days prior to the meeting date. COA approved ESC Plan and TPDES SWPPP (if required) should be reviewed by COA EV Inspector at this time.
5. Any major variation in materials or locations of controls or fences from those shown on the approved plans will require a revision and must be approved by the reviewing Engineer, Environmental Specialist or City Arborist as appropriate. Major revisions must be approved by ~~the Planning and Development Review Department~~ authorized COA staff. Minor changes to be made as field revisions to the Erosion and Sedimentation Control Plan may be required by the Environmental Inspector during the course of construction to correct control inadequacies.
6. The contractor is required to provide a certified inspector with either a Certified Professional in Erosion and Sediment Control (CPESC), Certified Erosion, Sediment and Stormwater-Inspector (CESSWI) or Certified Inspector of Sedimentation and Erosion Controls (CISEC) certification to inspect the controls and fences at weekly intervals and after significant rainfall events to insure that they are functioning properly. The person(s) responsible for maintenance of controls and fences shall immediately make any necessary repairs to

damaged areas. Silt accumulation at controls must be removed when the depth reaches six (6) inches.

7. Prior to final acceptance by the City, haul roads and waterway crossings constructed for temporary contractor access must be removed, accumulated sediment removed from the waterway and the area restored to the original grade and revegetated. All land clearing debris shall be disposed of in approved spoil disposal sites.
8. All work must stop if a void in the rock substrate is discovered which is; one square foot in total area; blows air from within the substrate and/or consistently receives water during any rain event. At this time it is the responsibility of the Project Manager to immediately contact a City of Austin Environmental Inspector for further investigation.
9. Temporary and Permanent Erosion Control: All disturbed areas shall be restored as noted below.
 - A. All disturbed areas to be revegetated are required to place a minimum of six (6) inches of topsoil [see Standard Specification Item No. 601S.3(A)]. Do not add topsoil within the critical root zone of existing trees. ~~The topsoil shall be composed of 4 parts of soil mixed with 1 part compost, by volume. The compost shall meet the definition of compost as defined by TxDOT Specification Item 161. The soil shall be locally available native soil that meets the following specifications:~~
 - ~~• Shall be free of trash, weeds, deleterious materials, rocks, and debris.~~
 - ~~• 100% shall pass through a 1.5-inch (38-mm) screen.~~
 - ~~• Soil to be a loamy material that meets the requirements of the table below in accordance with the USDA textural triangle. Soil known locally as "red death" is not an allowable soil. Textural composition shall meet the following criteria:~~

Textural Class	Minimum	Maximum
Clay	5%	50%
Silt	10%	50%
Sand	15%	67%

- Topsoil salvaged from the existing site is encouraged for use, but it should meet the standards set forth in 601S.

An owner/engineer may propose use of onsite salvaged topsoil which does not meet the criteria of Standard Specification 601S soil texture class required above by

providing a soil analysis and a written statement from a qualified professional in soils, landscape architecture, or agronomy indicating the onsite topsoil will provide an equivalent growth media and specifying what, if any, soil amendments are required.

- Soil amendments shall be worked into the existing onsite topsoil with a disc or tiller to create a well-blended material.

~~Topsoil salvaged from the existing site may often be used, but it should meet the same standards as set forth in these standards.~~

The vegetative stabilization of areas disturbed by construction shall be as follows:

TEMPORARY VEGETATIVE STABILIZATION:

1. From September 15 to March 1, seeding shall be with or include a cool season cover crops:~~(Western Wheatgrass (*Pascopyrum smithii*) at 0.5 pounds per 1000 SF-5.6 pounds per acre, Oats (*Avena sativa*) at 0.5 pounds per 1000 SF-4.0 pounds per acre, Cereal Rye Grain (*Secale cereale*) at 0.5 pounds per 1000 SF) 45 pounds per acre with a total rate of 1.5 pounds per 1000 SF. Contractor must ensure that any seed application requiring a cool season cover crop does not utilize annual ryegrass (*Lolium multiflorum*) or perennial ryegrass (*Lolium perenne*). Cool season cover crops are not permanent erosion control.~~
2. From March 2 to September 14, seeding shall be with hulled Bermuda at a rate of ~~1 pounds per 1000 SF~~45 pounds per acre or a native plant seed mix conforming to Items 604S or 609S.
 - A. Fertilizer shall be ~~water soluble with an analysis of 15-15-15 to be applied once at planting and once during the period of establishment at a rate of 1/2 pound per 1000 SF~~applied only if warranted by a soil test and shall conform to Item No. 606S, Fertilizer. Fertilization should not occur when rainfall is expected or during slow plant growth or dormancy. Chemical fertilizer may not be applied in the Critical Water Quality Zone.
 - B. Hydromulch shall comply with Table 1, below.
 - C. Temporary erosion control shall be acceptable when the grass has grown at least 1½ inches high with a minimum of 95% total coverage so that all areas of a site that rely on vegetation for temporary stabilization are uniformly vegetated, and provided there are no bare spots larger than 10 16-square feet exist.
 - D. When required, native ~~grass plant~~ seeding shall comply with requirements of the City of Austin Environmental Criteria Manual, and Standard Specifications 604S or 609S.

Table 1: Hydromulching for Temporary Vegetative Stabilization

Material	Description	Longevity	Typical Applications	Application Rates

100% or any blend of wood, cellulose, straw, and/or cotton plant material (except no mulch shall exceed 30% paper)	70% or greater Wood/Straw 30% or less Paper or Natural Fibers	0-3 months	Moderate slopes; from flat to 3:1	1500 to 2000 lbs per acre
--	---	------------	-----------------------------------	---------------------------

PERMANENT VEGETATIVE STABILIZATION:

1. From September 15 to March 1, seeding is considered to be temporary stabilization only. If cool season cover crops exist where permanent vegetative stabilization is desired, the grasses shall be mowed to a height of less than one-half (½) inch and the area shall be re-seeded in accordance with Table 2 below. Alternatively, the cool season cover crop can be mixed with Bermudagrass or native seed and installed together, understanding that germination of warm-season seed typically requires soil temperatures of 60 to 70 degrees.
2. From March 2 to September 14, seeding shall be with hulled Bermuda at a rate of ~~1 pound per 1000 SF~~ 45 pounds per acre with a purity of 95% and with 85% germination a minimum pure live seed (PLS) of 0.83. Bermuda grass is a warm season grass and is considered permanent erosion control. Permanent vegetative stabilization can also be accomplished with a native plant seed mix conforming to Items 604S or 609S.
 - A. Fertilizer use shall follow the recommendation of a soil test. See Item 606S, Fertilizer. Applications of fertilizer (and pesticide) on City-owned and managed property requires the yearly submittal of a Pesticide and Fertilizer Application Record, along with a current copy of the applicator’s license. For current copy of the record template contact the City of Austin’s IPM Coordinator. ~~shall be a water soluble with an analysis of 15-15-15 to be applied once at planting and once during the period of establishment at a rate of ½ pound per 1000 SF.~~ Hydromulch shall comply with Table 2, below.
 - C. ~~The planted area shall be irrigated or sprinkled in a manner that will not erode the topsoil, but will sufficiently soak the soil to a depth of six inches. The irrigation shall occur at daily intervals (minimum) during the first two months. Rainfall occurrences of ½ inch or more shall postpone the watering schedule for one week.~~ Water the seeded areas immediately after installation to achieve germination and a healthy stand of plants that can ultimately survive without supplemental water. Apply the water uniformly to the planted areas without causing displacement or erosion of the materials or soil. Maintain the seedbed in a moist condition favorable for plant growth. All watering shall comply with City Code Chapter 6-4 (Water Conservation), at rates and frequencies determined by a licensed irrigator or other qualified professional, and as allowed by the Austin Water Utility and current water restrictions and water conservation initiatives.

- D. Permanent erosion control shall be acceptable when the grass has grown at least 1½ inches high with 95%—a minimum of 95 percent for the non-native mix, and 95 percent coverage for the native mix so that all areas of a site that rely on vegetation for stability must be uniformly vegetated, and provided there are no bare spots larger than 16 square feet—exist.
- E. When required, native ~~grass~~ plant seeding shall comply with requirements of the City of Austin Environmental Criteria Manual, Items # 604S and 609S.

Table 2: Hydromulching for Permanent Vegetative Stabilization

Material	Description	Longevity	Typical Applications	Application Rates
Bonded Fiber Matrix (BFM)	80% Organic defibrated fibers			
10% Tackifier	6 months	On slopes up to 2:1 and erosive soil conditions	2500 to 4000 lbs per acre (see manufacturers recommendations)	
Fiber Reinforced Matrix (FRM)	65% Organic defibrated fibers 25% Reinforcing Fibers or less 10% Tackifier	Up to 12 months	On slopes up to 1:1 and erosive soil conditions	3000 to 4500 lbs per acre (see manufacturers recommendations)

10. Developer Information:

Owner _____ Phone # _____

Address _____

Owner's representative responsible for plan alterations: _____ Phone # _____

Person or firm responsible for erosion/sedimentation control maintenance: _____ Phone # _____

Person or firm responsible for tree/natural area protection Maintenance: _____ Phone #

11. The contractor shall not dispose of surplus excavated material from the site without notifying the Planning and Development Review Department at 974-2278 at least 48 hours prior with the location and a copy of the permit issued to receive the material.

NEW APPENDIX R-8

**APPENDIX R-8
POROUS PAVEMENT SYSTEM CALCULATIONS
FOR DEVELOPMENT PERMITS**

Porous Pavement Data:

Porous Pavement System Proposed (See ECM 1.6.7.E) circle one:

Open-Jointed Block Paver

Porous Asphalt

Porous Concrete (pedestrian use only)

Impervious Cover Percentage	100	%
Capture Depth (CD)	1.3	inches
Depth of Porous Pavement System Gravel or Open Graded Base Layer	≥ 5	inches
Effective Porosity of Gravel Bed	assume 0.30	
Saturated Hydraulic Conductivity (Ksat) of Subgrade	≥ 0.2	inches / hour

WATER QUALITY CONTROL CALCULATIONS

Provided

Porous Pavement System Proposed in acres (A_{pp})

(No off site run on allowed $A_{pp} = A_{total}$)

_____ **acres**

Required Water Quality Volume ($WQV = CD * A_{total} * 3630$)

_____ **cubic feet**

Saturated Hydraulic Conductivity

_____ **in/hr**

Porous Pavement System Drawdown Time

_____ **hours**

REMOVE EXISTING APPENDIX R-8

APPENDIX R-8 - POROUS PAVEMENT SYSTEM CALCULATIONS PEDESTRIAN USE ONLY FOR DEVELOPMENT PERMITS

APPENDIX R-8 POROUS PAVEMENT SYSTEM CALCULATIONS PEDESTRIAN USE ONLY FOR DEVELOPMENT PERMITS

POROUS PAVEMENT DATA:

Porous Pavement Proposed in acres - no off site run on ($A_{pp} = A_{total}$)

_____ cf

Impervious cover %

100 %

Capture Depth (CD)

13 in

Total Site Required Water Quality Volume ($WQV = CD * A_{pp} * 3630$)

_____ cf

WATER QUALITY CONTROL CALCULATIONS:

Required _____

Provided _____

The Water Quality Control is to be Porous Pavement

Depth of Porous Pavement System (L)

> 3.0 in

_____ in

Effective Porosity of Gravel Bed (n_e)

assume 0.30

Water Quality Volume Reduction (WQV)

_____ cf

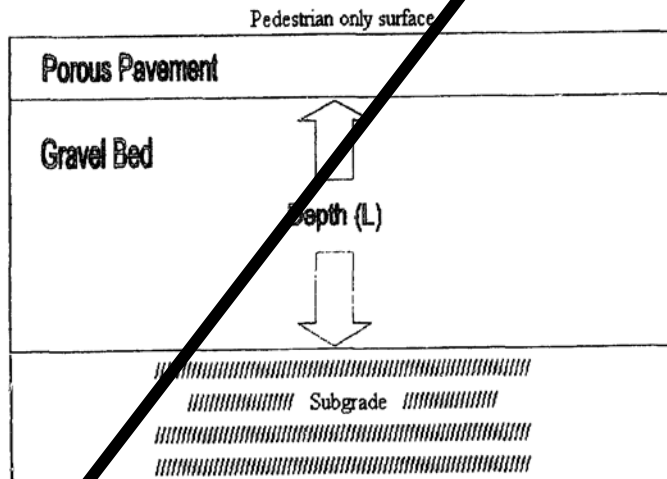

APPENDIX R: - WATER QUALITY CONTROL CALCULATIONS

R-1 Full and Partial Sedimentation/Filtration pond, Biofiltration pond, and Vegetative Filter Strips Calculations for Preliminary Plans and Final Plans

R-2 Full Sedimentation/Filtration Pond Calculations for Development Permits.

R-3 Partial Sedimentation/Filtration Pond Calculations for Development Permits

R-4 Wet Pond Calculations for Development Permits

R-5 Retention/Irrigation System Calculations for Development Permits

R-6 Full or Partial Biofiltration Pond Calculations for Development Permits

R-7 Rainwater Harvesting System Calculations for Development Permits

R-8 Porous Pavement System ~~for Pedestrian Use~~ Calculations for Development Permits

R-9 Vegetative Filter Strip - Disconnected Impervious Cover Calculations for Developments Permits

R-10 Non-Required Vegetation Calculations for Development Permits

R-11 Rain Garden Calculations for Development Permits

Appendix X: Functional Assessment of Floodplain Health

Introduction: The Functional Assessment was developed by a cross-discipline team of ecologists, engineers, statisticians, and policymakers. The intent was to provide a simple, accurate, and locally-derived tool to assess specific functional characteristics of three discrete units: the floodplain outside of the Critical Water Quality Zone (CWQZ), the Critical Water Quality Zone, and the active channel. For more detail on the regulatory requirements for floodplain modification, see 1.7.0 (*Floodplain Modification Criteria*) of this manual.

With the exception of Zone 4, A a 100 meter transect length will be the base unit for this assessment, which is consistent with other stream assessment tools. However, depending on the size of the area being modified, the heterogeneity of the system, and other variables, the measurement unit can vary, as long as the rationale and scale are clearly defined in the application process. These tools will be utilized to assess floodplains with modifications proposed as well as to assess the Critical Water Quality Zone and/or the active channel before they are restored. These tools will also be used post-restoration to assess the successful completion of the restoration required in the Critical Water Quality Zone and/or the active channel.

The measures selected for the Zone 1 assessment tool are based primarily on riparian vegetation, but also include soil compaction. These measures are a subset of a City of Austin-developed tool called the Riparian Functional Assessment (RFA), which is currently used by the Watershed Protection Department to perform riparian zone assessments citywide. The Zone 1 assessment will require a tape measure, a soil compaction meter, and some experience with field vegetative assessment methods. For a 100 meter transect, the assessment should take about 1 hour, but ultimately will depend on the age of the vegetative community. The more degraded the site, the faster the assessment will go. If the assessment needs to be performed between November and February, the assessment may be performed by staff from the Watershed Protection Department, due to a seasonal lack of vegetation.

The measures selected for the Zone 2 assessment are also taken from the Riparian Functional Assessment and are intended to measure the functional characteristics of riparian vegetation plus a measure of soil compaction. The Zone 2 assessment will use the same field instruments as Zone 1 and should

take approximately 1.5 hours for a 100 meter reach of a stream. Again, this will depend on the age and structure of the riparian community. If the assessment needs to be performed between November and February, the assessment may be performed by staff from the Watershed Protection Department, due to a seasonal lack of vegetation.

The Zone 3 assessment includes riparian measures along the immediate banks and overbank, geomorphic characteristics including channel stability characteristics, and in-stream aquatic habitat characteristics. The majority of the measures for the Zone 3 assessment were derived from national assessment tools developed by the U.S. Forest Service (Pfankuch 1975) and the Environmental Protection Agency (Barbour et al. 1999), but it also includes riparian measures from the Riparian Functional Assessment and geomorphic measures developed by the EPA (Harman et al. 2012) and the Watershed Protection Department. The Zone 3 assessment may be performed by staff from the Watershed Protection Department and is required when a proposed site development includes modifications to the active channel to achieve a “significant, demonstrable environmental benefit.” This assessment will require the same field instruments as the Zone 1 and 2 assessments, plus a densiometer and a stadia rod. It will assess the existing conditions and proposed improvements by characterizing the channel in 100 meter reach lengths. Depending on the stream length where proposed improvements are planned, the assessment should take between 2 to 8 hours to complete.

The Zone 4 assessment includes three measures that focus exclusively on the density, structure, and diversity of riparian vegetation. These measures are also utilized in the assessments for the other zones, but are more appropriate for the shoreline of constant-level lakes which may include a significant component of residential land-use. The total transect length is dependent on the linear distance of shoreline for the parcel.

The applicant should submit the applicable worksheets (scoring and field sheets), depending on the level and scale of floodplain modification proposed. In addition to the completed worksheets, the applicant should also submit:

- a map of the area proposed for floodplain modification
- a map of the area proposed for riparian restoration
- a map of the established 100-meter transects
- photo documentation of the areas assessed

Scoring: Zone 1 – Floodplain Health

Site/Project Name: _____

Date: _____ Time: _____

Transect Number: _____

Staff (if applicable): _____

Parameter	Excellent (4)	Good (3)	Fair (2)	Poor (1)	Score
Gap Frequency <i>A visual assessment of the number of gaps in vegetation.</i>	0 - 20% of area has visual gaps in vegetation	20% - 40% of area has visual gaps in vegetation	40 - 60% of area has visual gaps in vegetation	> 60% of area has visual gaps in vegetation	
Large Woody Debris <i>An evaluation of the amount of large woody debris.</i>	7 or more pieces of large woody debris	5 - 6 pieces of large woody debris	3 - 4 pieces of large woody debris	2 or less pieces of large woody debris	
Soil Compaction <i>An assessment of the bulk density of the soil.</i>	0 - 200 <u>125</u> pounds per square inch	201 <u>126</u> - 400 <u>175</u> pounds per square inch	401 <u>176</u> - 600 <u>225</u> pounds per square inch	> 600 <u>225</u> pounds per square inch	
Structural Diversity <i>An evaluation of the canopy and understory vegetation.</i>	> 65% canopy; or > 50% canopy and > 50% understory	51 - 65% canopy; or 0 - 50% canopy and > 40% understory	31 - 50% canopy; or 0 - 30% canopy and > 30% understory	0 - 30% canopy; or 0 - 15% canopy and 0 - 30% understory	
Tree Demography <i>An assessment of the age class distribution of all canopy tree species.</i>	Canopy tree species are present in all 4 age classes	Canopy tree species are present in 3 of 4 age classes	Canopy tree species are present in 2 of 4 age classes	Canopy tree species are present in only 1 age class or no trees	

Assessed Condition (Circle One)

Excellent: 18 - 20

Good: 13 - 17

Zone 1 Score: _____
Fair: 8 - 12

Poor: 5 - 7

Methodology: Zone 1 – Floodplain Health

Establishing Transects and Sample Plots: For the area proposed for floodplain modification in Zone 1, the applicant should establish 100 meter transects along the edge closest to the waterway. Each 100 meter transect will need a separate assessment and scoring sheet. Establish 100 square meter sampling plots at 5, 50, and 95 meters along each transect on the side of the transect within the area proposed for floodplain modification. This is done by running 5 meters upstream and 5 meters downstream along the transect and then moving outward 10 meters perpendicular to the transect and away from the stream.

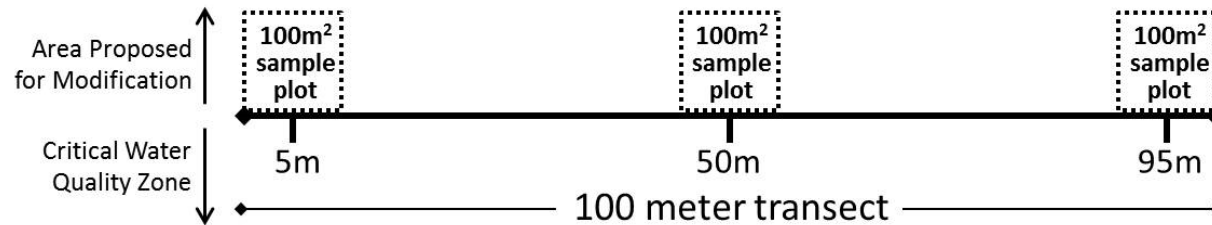

Gap Frequency: Along the entire 100 meter transect, estimate the relative frequency of vegetative buffer gaps observed within 10 meters upslope of the transect. A vegetative buffer gap is defined as a void in vegetation ≥ 1 meter wide where surface runoff has an unimpeded path toward the stream channel. An unimpeded path exists if no vegetation higher than 12 inches is present. Woody vegetation must consist of a multi-stemmed trunk with a total diameter of ≥ 5 inches or a single trunk with a diameter of ≥ 5 inches in order to be considered as impeding the flow path. Tally all 1 meter buffer gaps along the 100 meter transect which equates to the overall percentage because the transect is 100 meters.

Large Woody Debris: Along the entire 100 meter transect, record the number of large woody debris pieces observed within 10 meters upslope of the transect. Large woody debris is defined as wood that is fully or partially exposed and is at least 6 inches in diameter and 3 feet in length.

Soil Compaction: In the center of each 100 square meter sample plot, position the tip of the soil compaction meter on the ground. Apply even downward pressure on both handles at a slow, even pace and record the gauge reading at a depth of 3 inches. A total of three measurements should be taken from each plot. Average all the readings from the three sample plots to calculate the overall score.

Structural Diversity: Within each 100 square meter sample plot, estimate the percent cover of the canopy and understory vegetation layers by using the shadow cast by each particular layer. The canopy layer is > 5 meters high and the understory is 0.5 to 5 meters high. The surveyors should walk the sample plot, focusing on one vegetation category at a time and then agree on one value to record. To help obtain an accurate estimate, run a measuring tape to better define the study area or divide the sample plot into smaller units. Average the percentages from the three sample plots to calculate the overall score.

Tree Demography: Within each 100 square meter sample plot, record the species of canopy trees present and then record the presence or absence of canopy woody species at multiple age classes (seedlings, saplings, mature, and snags). See reference list of canopy woody species below. Seedlings are defined as 12 inches or less, having sprouted within the last year. Saplings are > 12 inches in height, but have yet to reach half their mature height and lack a fully-developed canopy. Mature trees are approaching their maximum height and display a fully-developed canopy. Snags are standing dead trees with little to no vegetation and reduced canopy coverage. Average the number of age classes observed from the three sample plots to calculate the overall score.

Methodology: Zone 1 – Floodplain Health

Reference List of Canopy Woody Species

(Significant Shade Providers from ECM Appendix F: Descriptive Categories of Tree Species)

Common Name	Scientific Name	Common Name	Scientific Name
Anacua	<i>Ehretia anacua</i>	Oak, Chinquapin	<i>Quercus muehlenbergii</i>
Ash, Green	<i>Fraxinus pennsylvanica</i>	Oak, Durand	<i>Quercus sinuata</i> var. <i>sinuata</i>
Bois D'Arc	<i>Maclura pomifera</i>	Oak, Lacey	<i>Quercus laceyi</i>
Bumelia, Gum	<i>Sideroxylon lanuginosum</i>	Oak, Live (Coastal)	<i>Quercus virginiana</i>
Catalpa	<i>Catalpa</i> spp.	Oak, Live (Plateau)	<i>Quercus fusiformis</i>
Cedar, Eastern Red	<i>Juniperus virginiana</i>	Oak, Mexican White	<i>Quercus polymorpha</i>
Cherry, Escarpment Black	<i>Prunus serotina</i> var. <i>eximia</i>	Oak, Post	<i>Quercus stellata</i>
Cherry-Laurel, Carolina	<i>Prunus caroliniana</i>	Oak, Shin	<i>Quercus sinuata</i> var. <i>breviloba</i>
Cypress, Arizona	<i>Cupressus arizonica</i>	Oak, Shumard Red	<i>Quercus shumardii</i>
Cypress, Bald	<i>Taxodium distichum</i>	Oak, Texas Red	<i>Quercus texana</i>
Cypress, Montezuma	<i>Taxodium mucronatum</i>	Pecan	<i>Carya illinoensis</i>
Elm, American	<i>Ulmus Americana</i>	Persimmon, Common	<i>Diospyros virginiana</i>
Elm, Cedar	<i>Ulmus crassifolia</i>	Pistache, Texas	<i>Pistacia texana</i>
Hackberry	<i>Celtis</i> spp.	Soapberry	<i>Sapindus drummondii</i>
Hickory, Mockernut	<i>Carya alba</i>	Sycamore, American	<i>Platanus occidentalis</i>
Juniper, Ashe	<i>Juniperus ashei</i>	Sycamore, Mexican	<i>Platanus mexicana</i>
Magnolia, Southern	<i>Magnolia grandiflora</i>	Walnut, Arizona	<i>Juglans major</i>
Maple, Bigtooth	<i>Acer grandidentatum</i>	Walnut, Eastern Black	<i>Juglans nigra</i>
Oak, Blackjack	<i>Quercus marilandica</i>	Walnut, Little	<i>Juglans microcapra</i>
Oak, Bur	<i>Quercus macrocarpa</i>		

Field Sheet: Zone 1 – Floodplain Health

Site/Project Name: _____

Date: _____ Time: _____

Transect Number: _____

Staff (if applicable): _____

Gap Frequency

Number of 1 meter gaps: _____

Large Woody Debris

Percent of Transect: _____ %

Number of Large Woody Debris Pieces: _____

Soil Compaction

Plot 1 (5 meters)	Plot 2 (50 meters)	Plot 3 (95 meters)
#1: _____ psi #2: _____ psi #3: _____ psi	#1: _____ psi #2: _____ psi #3: _____ psi	#1: _____ psi #2: _____ psi #3: _____ psi
Average for Plot 1: _____ psi	Average for Plot 2: _____ psi	Average for Plot 3: _____ psi

Average for All Sample Plots: _____ psi

Structural Diversity

Plot 1 (5 meters)	Plot 2 (50 meters)	Plot 3 (95 meters)
Canopy: _____ % Understory: _____ %	Canopy: _____ % Understory: _____ %	Canopy: _____ % Understory: _____ %

Average for All Sample Plots: Canopy: _____ % Understory: _____ %

Tree Demography

Plot 1 (5 meters)	Plot 2 (50 meters)	Plot 3 (95 meters)
Number of Age Classes: _____	Number of Age Classes: _____	Number of Age Classes: _____

Average for All Sample Plots: _____

Scoring: Zone 2 – Critical Water Quality Zone

Site/Project Name: _____

Date: _____

Time: _____

Transect Number: _____

Staff (if applicable): _____

Parameter	Excellent (4)	Good (3)	Fair (2)	Poor (1)	Score
Gap Frequency <i>A visual assessment of the number of gaps in vegetation.</i>	0 - 20% of riparian area has visual gaps in vegetation	20% - 40% of riparian area has visual gaps in vegetation	40 - 60% of riparian area has visual gaps in vegetation	> 60% of riparian area has visual gaps in vegetation	
Large Woody Debris <i>An evaluation of the amount of large woody debris.</i>	7 or more pieces of large woody debris	5 - 6 pieces of large woody debris	3 - 4 pieces of large woody debris	2 or less pieces of large woody debris	
Soil Compaction <i>An assessment of the bulk density of the soil.</i>	0 - 200 <u>125</u> pounds per square inch	201 <u>126</u> - 400 <u>175</u> pounds per square inch	401 <u>176</u> - 600 <u>225</u> pounds per square inch	> 600 <u>225</u> pounds per square inch	
Structural Diversity <i>An evaluation of the canopy and understory vegetation.</i>	> 65% canopy; or > 50% canopy and > 50% understory	51 - 65% canopy; or 0 - 50% canopy and > 40% understory	31 - 50% canopy; or 0 - 30% canopy and > 30% understory	0 - 30% canopy; or 0 - 15% canopy and 0 - 30% understory	
Tree Demography <i>An assessment of the age class distribution of all canopy tree species.</i>	Canopy tree species are present in all 4 age classes	Canopy tree species are present in 3 of 4 age classes	Canopy tree species are present in 2 of 4 age classes	Canopy tree species are present in only 1 age class or no trees	
Wetland Tree Status <i>Percent of total trees that are defined as FAC+ or greater with respect to wetland status.</i>	> 65% of trees are FAC+ or greater	50 - 65% of trees are FAC+ or greater	25 - 49% of trees are FAC+ or greater	< 25% of trees are FAC+ or greater	
Riparian Zone Width <i>A measure of the width of the undisturbed riparian zone.</i>	> 18 meters or > 75% of the CWQZ	12 - 18 meters or 50 - 75% of the CWQZ	6 - 12 meters or 25 - 49% of the CWQZ	< 6 meters or < 25% of the CWQZ	

Zone 2 Score: _____

Assessed Condition (Circle One)

Excellent: 25 - 28

Good: 18 - 24

Fair: 11 - 17

Poor: 7 - 10

Methodology: Zone 2 – Critical Water Quality Zone

Establishing Transects and Sample Plots: For the area proposed for restoration in Zone 2, the applicant should establish 100 meter transects. Each 100 meter transect will need a separate assessment and scoring sheet. Establish 100 square meter sampling plots at 5, 50, and 95 meters along the transect on the side of the stream adjacent to the proposed floodplain modification (Zone 1). This is done by running 5 meters upstream and 5 meters downstream and then moving outward 10 meters perpendicular to the transect and into the riparian zone.

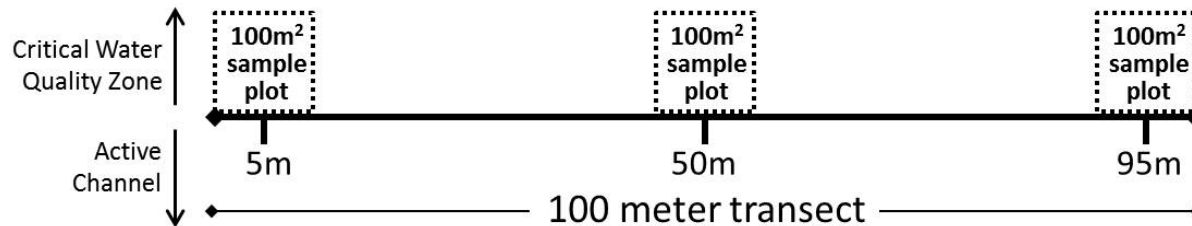

Gap Frequency: Along the entire 100 meter transect, estimate the relative frequency of riparian buffer gaps. A riparian buffer gap is defined as a void in vegetation ≥ 1 meter wide where surface runoff has an unimpeded path to the stream channel. An unimpeded path exists if no vegetation higher than 12 inches is present. Woody vegetation must consist of a multi-stemmed trunk with a total diameter of ≥ 5 inches or a single trunk with a diameter of ≥ 5 inches in order to be considered as impeding the flow path. Tally all 1 meter buffer gaps along the 100 meter transect which equates to the overall percentage because the transect is 100 meters.

Large Woody Debris: Along the entire 100 meter transect, record the number of large woody debris pieces observed. Large woody debris is defined as wood that is fully or partially exposed and is at least 6 inches in diameter and 3 feet in length.

Soil Compaction: In the center of each 100 square meter sample plot, position the tip of the soil compaction meter on the ground. Apply even downward pressure on both handles at a slow, even pace and record the gauge reading at a depth of 3 inches. A total of three measurements should be taken from each plot. Average all the readings from the three sample plots to calculate the overall score.

Structural Diversity: Within each 100 square meter sample plot, estimate the percent cover of the canopy and understory vegetation layers by using the shadow cast by each particular layer. The canopy layer is > 5 meters high and the understory is 0.5 to 5 meters high. The surveyors should walk the sample plot, focusing on one vegetation category at a time and then agree on one value to record. To help obtain an accurate estimate, run a measuring tape to better define the study area or divide the sample plot into smaller units. Average the percentages from the three sample plots to calculate the overall score.

Tree Demography: Within each 100 square meter sample plot, record the species of canopy trees present and then record the presence or absence of canopy woody species at multiple age classes (seedlings, saplings, mature, and snags). See reference list of canopy woody species in Zone 1 Methodology. Seedlings are defined as 12 inches or less, having sprouted within the last year. Saplings are > 12 inches in height, but have yet to reach half their mature height and lack a fully-developed canopy. Mature trees are approaching their maximum height and display a fully-developed canopy. Snags are standing dead trees with little to no vegetation and reduced canopy coverage. Average the number of age classes observed from the three sample plots to calculate the overall score.

Wetland Tree Status: Within each 100 square meter sample plot, perform a brief inventory of tree species composition and abundance. Verify the wetland status of each taxa and convert to a percent of total trees that are FAC+ or greater (FAC+, FACW-, FACW, FACW+, and OBL) with respect to wetland indicator

status (i.e. number of FAC+ or greater trees / total number of trees present). See reference list of FAC+ or greater tree species below. Average the percentages from the three sample plots to calculate the overall score.

Methodology: Zone 2 – Critical Water Quality Zone

Reference List of FAC+ or Greater Tree Species

(from National List of Plant Species that Occur in Wetlands)

Common Name(s)	Scientific Name	Wetland Rating
American elder, elderberry	<i>Sambucus canadensis</i>	FAC+
American sycamore	<i>Platanus occidentalis</i>	FAC+
Pecan	<i>Carya illinoensis</i>	FAC+
Box elder	<i>Acer negrundo</i>	FACW-
Deciduous holly, possum haw	<i>Ilex decidua</i>	FACW-
Green ash	<i>Fraxinus pennsylvanica</i>	FACW-
Hemp sesbania	<i>Sesbania herbacea (S. exaltata)</i>	FACW-
Northern spicebush	<i>Lindera benzoin</i>	FACW-
Black walnut	<i>Juglans nigra</i>	FACW
Delta post oak	<i>Quercus stellata</i>	FACW
False indigo bush	<i>Amorpha fruticosa</i>	FACW
Rattle bush	<i>Sesbania drummondii</i>	FACW
Black willow	<i>Salix nigra</i>	FACW+
Bald cypress	<i>Taxodium dystichum</i>	OBL
Buttonbush	<i>Cephalanthus occidentalis</i>	OBL

Note: Refer to the most recent version of the National Wetland Plant List at <http://rsgisias.crrel.usace.army.mil/NWPL/>

Riparian Zone Width: At 5, 50, and 95 meters along the transect, run a measuring tape from the edge of the active channel perpendicular away from the stream channel to the edge of the undisturbed riparian vegetation or the end of the Critical Water Quality Zone, whichever comes first. The edge of the riparian zone buffer is often dictated by a human structure (house, fence, road) or management activity (agriculture, mowing) that inhibits plant growth and alters the availability of the soil and vegetation to filter surface runoff. Average the measurements from the three locations to calculate the overall score.

Field Sheet: Zone 2 – Critical Water Quality Zone

Site/Project Name: _____

Date: _____ Time: _____

Transect Number: _____

Staff (if applicable): _____

Gap Frequency

Number of 1 meter gaps: _____

Large Woody Debris

Percent of Transect: _____ %

Number of Large Woody Debris Pieces: _____

Soil Compaction

Plot 1 (5 meters)	Plot 2 (50 meters)	Plot 3 (95 meters)
#1: _____ psi #2: _____ psi #3: _____ psi	#1: _____ psi #2: _____ psi #3: _____ psi	#1: _____ psi #2: _____ psi #3: _____ psi
Average for Plot 1: _____ psi	Average for Plot 2: _____ psi	Average for Plot 3: _____ psi

Average for All Sample Plots: _____ psi

Structural Diversity

Plot 1 (5 meters)	Plot 2 (50 meters)	Plot 3 (95 meters)
Canopy: _____ % Understory: _____ %	Canopy: _____ % Understory: _____ %	Canopy: _____ % Understory: _____ %

Average for All Sample Plots: Canopy: _____ % Understory: _____ %

Tree Demography

Plot 1 (5 meters)	Plot 2 (50 meters)	Plot 3 (95 meters)
Number of Age Classes: _____	Number of Age Classes: _____	Number of Age Classes: _____

Average for All Sample Plots: _____

Field Sheet: Zone 2 – Critical Water Quality Zone

Site/Project Name: _____

Date: _____ Time: _____

Transect Number: _____

Staff (if applicable): _____

Wetland Tree Status

Plot 1 (5 meters)	Plot 2 (50 meters)	Plot 3 (95 meters)
Number of FAC+ or Greater Trees: _____	Number of FAC+ or Greater Trees: _____	Number of FAC+ or Greater Trees: _____
Total Number of Trees: _____	Total Number of Trees: _____	Total Number of Trees: _____
Percent FAC+ or Greater: _____ %	Percent FAC+ or Greater: _____ %	Percent FAC+ or Greater: _____ %

Average for All Sample Plots: _____ %

Riparian Zone Width

Measurement 1 (5 meters)	Measurement 2 (50 meters)	Measurement 3 (95 meters)
Riparian Zone Width: _____ m	Riparian Zone Width: _____ m	Riparian Zone Width: _____ m

Average for All Measurements: _____ m

Scoring: Zone 3 – Active Channel

Riparian Zone

Site/Project Name: _____

Date: _____

Time: _____

Transect Number: _____

Staff (if applicable): _____

Parameter	Excellent (4)	Good (3)	Fair (2)	Poor (1)	Score
Gap Frequency <i>A visual assessment of the number of gaps in vegetation.</i>	0 - 20% of riparian area has visual gaps in vegetation	20% - 40% of riparian area has visual gaps in vegetation	40 - 60% of riparian area has visual gaps in vegetation	> 60% of riparian area has visual gaps in vegetation	
Large Woody Debris <i>An evaluation of the amount of large woody debris.</i>	7 or more pieces of large woody debris	5 - 6 pieces of large woody debris	3 - 4 pieces of large woody debris	2 or less pieces of large woody debris	
Soil Compaction <i>An assessment of the bulk density of the soil.</i>	0 - 200 <u>125</u> pounds per square inch	201 <u>126</u> - 400 <u>175</u> pounds per square inch	401 <u>176</u> - 600 <u>225</u> pounds per square inch	> 600 <u>225</u> pounds per square inch	
Structural Diversity <i>An evaluation of the canopy and understory vegetation.</i>	> 65% canopy; or > 50% canopy and > 50% understory	51 - 65% canopy; or 0 - 50% canopy and > 40% understory	31 - 50% canopy; or 0 - 30% canopy and > 30% understory	0 - 30% canopy; or 0 - 15% canopy and 0 - 30% understory	
Tree Demography <i>An assessment of the age class distribution of all canopy tree species.</i>	Canopy tree species are present in all 4 age classes	Canopy tree species are present in 3 of 4 age classes	Canopy tree species are present in 2 of 4 age classes	Canopy tree species are present in only 1 age class or no trees	
Wetland Tree Status <i>Percent of total trees that are defined as FAC+ or greater with respect to wetland status.</i>	> 65% of trees are FAC+ or greater	50 - 65% of trees are FAC+ or greater	25 - 49% of trees are FAC+ or greater	< 25% of trees are FAC+ or greater	
Riparian Zone Width <i>A measure of the width of the undisturbed riparian zone.</i>	> 18 meters or > 75% of the CWQZ	12 - 18 meters or 50 - 75% of the CWQZ	6 - 12 meters or 25 - 49% of the CWQZ	< 6 meters or < 25% of the CWQZ	
In-Stream Canopy Cover <i>An assessment of the amount of canopy cover extending over the stream banks.</i>	> 75% canopy cover	50 - 75% canopy cover	25 - 49% canopy cover	< 25% canopy cover	

Riparian Zone Score: _____

Assessed Condition (Circle One)

Excellent: 29 - 32

Good: 21 - 28

Fair: 13 - 20

Poor: 8 - 12

Scoring: Zone 3 – Active Channel

Geomorphology

Site/Project Name: _____

Date: _____

Time: _____

Transect Number: _____

Staff (if applicable): _____

Parameter	Excellent (4)	Good (3)	Fair (2)	Poor (1)	Score
Mass Wasting <i>An evaluation of the existing and the potential for future major bank sloughing within the reach.</i>	No evidence of past or any potential for future mass wasting into channel.	Infrequent and/or very small. Mostly healed over. Low future potential.	Moderate frequency and size, with some raw spots eroded by water during high flows.	Frequent or large, causing sediment nearly yearlong or imminent danger of same.	
Vegetative Bank Protection <i>An evaluation of the amount and variety of vegetation covering the channel banks within the stream reach.</i>	> 90% plant density. Vigor and variety suggests a deep, dense, soil binding root mass.	70 - 90% density. Fewer plant species or lower vigor suggests a less dense or deep root mass.	50 - 70% density. Lower vigor and species form a somewhat shallow and discontinuous root mass.	< 50% density plus fewer species and vigor indicate discontinuous and shallow root mass.	
Obstructions, Deflectors, Sediment Traps <i>An evaluation of the presence of obstructions, deflectors, and sediment traps within the reach and of its relative permanence in the channel.</i>	Rocks and old logs firmly embedded. Flow pattern without cutting or deposition. Pools and riffles stable.	Some present, causing erosive cross currents and minor pool filling. Obstructions and deflectors newer and less firm.	Moderately frequent, unstable obstructions and deflectors move with high water causing bank cutting and filling of pools.	Frequent obstructions and deflectors cause bank erosion. Sediment traps' full channel migration occurring.	
Undercutting <i>An assessment of the prevalence and the height of cut and raw banks along the channel reach.</i>	Little or none evident. Infrequent, raw banks < 15 cm high.	Some, intermittently at outcurves and constrictions. Raw banks < 30 cm.	Significant. Cuts 30 - 60 cm high. Root mat overhangs and sloughing evident.	Almost continuous cuts, some > 60 cm high. Failure of overhangs.	
Deposition <i>An analysis of the amount of recent deposition of sediments in the reach resulting in new in-stream features such as bars, or filled-in pools.</i>	Little or no enlargement of channel or point bars.	Some new increase in bar formation, mostly from coarse gravels.	Moderate deposition of new gravel and coarse sand on old and some new bars.	Extensive deposits of predominantly fine particles. Accelerated bar development.	

Scoring: Zone 3 – Active Channel

Geomorphology

Site/Project Name: _____

Date: _____

Time: _____

Transect Number: _____

Staff (if applicable): _____

Parameter	Excellent (4)	Good (3)	Fair (2)	Poor (1)	Score
-----------	---------------	----------	----------	----------	-------

Consolidation or Particle Packing <i>An analysis of the degree to which stream bed particles are stabilized in the bed, either due to embeddedness or the orientation of the particles.</i>	Assorted sizes tightly packed and/or overlapping.	Moderately packed with some overlapping.	Mostly a loose assortment with no apparent overlap.	No packing evident. Loose, easily moved.	
Scouring and Deposition <i>An analysis of the extent of bed material mobilization within the reach, evidenced by scouring and/or deposition.</i>	< 5% of the bottom affected by scouring and deposition.	5 - 30% affected. Scour at constrictions and where steep. Pool deposition.	30 - 50% affected. Deposits and scour at obstructions, constrictions, and bends.	> 50% of bed in a state of flux or change nearly year-long.	
Entrenchment Ratio <i>An assessment of how entrenched the stream is.</i>	Little or no entrenchment. Ratio > 2.5	Minimal entrenchment. Ratio of 2.0 - 2.5	Moderate entrenchment. Ratio of 1.2 - 2.0	Highly entrenched. Ratio < 1.2	
Floodplain Connectivity/ Bank Height Ratio <i>An assessment of how easily storm flows inundate the floodplain.</i>	Functioning floodplain. Ratio of 1.0 - 1.2	Floodplain functioning but at risk. Ratio of 1.3 - 1.5	Floodplain not functioning. Ratio of 1.5 - 1.7	Severely degraded floodplain function. Ratio > 1.7	

Subtract up to 4 points for **Exposed Infrastructure** (2 pts.) and **Evidence of Headcuts** (2 pts.) **Deductions:** _____
Geomorphology Score: _____

Assessed Condition (Circle One) **Excellent:** ~~3229~~ - ~~3632~~ **Good:** ~~2321~~ - ~~3128~~ **Fair:** ~~1413~~ - ~~2220~~ **Poor:** ~~54~~ - ~~1312~~

Scoring: Zone 3 – Active Channel

Aquatic Habitat

Site/Project Name: _____

Date: _____

Time: _____

Transect Number: _____

Staff (if applicable): _____

Parameter	Excellent (4)	Good (3)	Fair (2)	Poor (1)	Score
-----------	---------------	----------	----------	----------	-------

<p>Epifaunal Substrate and Available Cover <i>An evaluation of the channel substrate, snags, submerged logs, and other stable habitat features to determine the amount of habitat available for epifaunal community colonization.</i></p>	<p>Greater than 70% of substrate favorable for epifaunal colonization and fish cover; mix of snags, submerged logs, undercut banks, cobble or other stable habitat and at stage to allow full colonization potential (i.e., logs/snags that are not new fall and not transient).</p>	<p>40 - 70% mix of stable habitat; well-suited for full colonization potential; adequate habitat for maintenance of populations; presence of additional substrate in the form of new fall, but not yet prepared for colonization.</p>	<p>20 - 40% mix of stable habitat; habitat availability less than desirable; substrate frequently disturbed or removed.</p>	<p>Less than 20% stable habitat; lack of habitat is obvious; substrate unstable or lacking.</p>	
<p>Embeddedness <i>An evaluation of the degree to which gravel, cobble, and boulder particles are surrounded by fine sediments.</i></p>	<p>Gravel, cobble, and boulder particles are 0 - 25% surrounded by fine sediment. Layering of cobble provides diversity of niche space.</p>	<p>Gravel, cobble, and boulder particles are 25 - 50% surrounded by fine sediment.</p>	<p>Gravel, cobble, and boulder particles are 50 - 75% surrounded by fine sediment.</p>	<p>Gravel, cobble, and boulder particles are more than 75% surrounded by fine sediment.</p>	
<p>Velocity/Depth Regimes <i>An evaluation of the presence of four categories of regimes: slow-deep, slow-shallow, fast-deep, and fast-shallow. Highest scores are assigned to reaches with all four velocity/depth regimes.</i></p>	<p>All four velocity/depth regimes present (slow-deep, slow-shallow, fast-deep, fast-shallow). Slow is < 0.3 m/s, deep is > 0.5 m.</p>	<p>Only 3 of the 4 regimes present (if fast-shallow is missing, score lower than if missing other regimes).</p>	<p>Only 2 of the 4 habitat regimes present (if fast-shallow or slow-shallow are missing, score low).</p>	<p>Dominated by 1 velocity/depth regime (usually slow-deep).</p>	

Scoring: Zone 3 – Active Channel

Aquatic Habitat

Site/Project Name: _____

Date: _____

Time: _____

Transect Number: _____

Staff (if applicable): _____

Parameter	Excellent (4)	Good (3)	Fair (2)	Poor (1)	Score
Sediment Deposition <i>An analysis of the degree to which in-stream features are enlarging, with areas with less than 5 percent of the reach affected by deposition receiving the highest scores.</i>	Little or no enlargement of islands or point bars and less than 5% (< 20% for low-gradient streams) of the bottom affected by sediment deposition.	Some new increase in bar formation, mostly from gravel, sand, or fine sediment; 5–30% (20–50% for low-gradient) of the bottom affected; slight deposition in pools.	Moderate deposition of new gravel, sand, or fine sediment on old and new bars; 30–50% (50–80% for low gradient) of the bottom affected; sediment deposits at obstructions, constrictions, and bends; moderate deposition of pools prevalent.	Heavy deposits of fine material, increased bar development; more than 50% (80% for low gradient) of the bottom changing frequently; pools almost absent due to substantial sediment deposition.	
Frequency of Riffles <i>An analysis of the occurrence of riffles, with reaches in which the average distance between riffles is less than seven times the channel's bankfull width receiving the highest scores.</i>	Riffles relatively frequent; ratio of distance between riffles divided by width of the stream < 7:1 (generally 5 to 7); variety of habitat is key.	Occurrence of riffles infrequent; distance between riffles divided by the width of the stream is between 7 to 15.	Occasional riffle or bend; bottom contours provide some habitat; distance between riffles divided by the width of the stream is between 15 to 25.	Generally all flat water or shallow riffles; poor habitat; distance between riffles divided by the width of the stream is a ratio of > 25.	
Flow Permanence Score <i>A statistical assessment of the degree of perennial flow for a stream reach, based on historical site visit and gage data.</i>	Flow permanence score from proximate EII reach > 85	Flow permanence score from proximate EII reach between 75 - 85	Flow permanence score from proximate EII reach between 45 - 74	Flow permanence score from proximate EII reach < 45	

Aquatic Habitat Score: _____

Assessed Condition (Circle One)

Excellent: ~~2218~~ - ~~2420~~

Good: ~~1613~~ - ~~2117~~

Fair: ~~108~~ - ~~1512~~

Poor: ~~65~~ - ~~97~~

Scoring: Zone 3 – Active Channel

Total Score

Site/Project Name: _____

Date: _____

Time: _____

Transect Number: _____

Staff (if applicable): _____

Final Scoring

Riparian Zone Score: _____
+ Geomorphology Score: _____
+ Aquatic Habitat Score: _____
Total Zone 3 Score: _____

Assessed Condition (Circle One) Excellent: ~~8275~~ - ~~9284~~ Good: ~~5954~~ - ~~8174~~ Fair: ~~3633~~ - ~~5853~~ Poor: ~~1917~~ - ~~3532~~

Methodology: Zone 3 – Active Channel

Establishing Transects and Sample Plots: For the active channel in Zone 3, the assessment will be performed using 100 meter in-stream longitudinal transects. Each 100 meter transect will need a separate assessment and scoring sheet. Establish 100 square meter sampling plots at 5, 50, and 95 meters along the transect for both sides of the stream (for a total of six). This is done by running 5 meters upstream and downstream and 10 meters perpendicular to the stream into the riparian zone beginning at the edge of active channel.

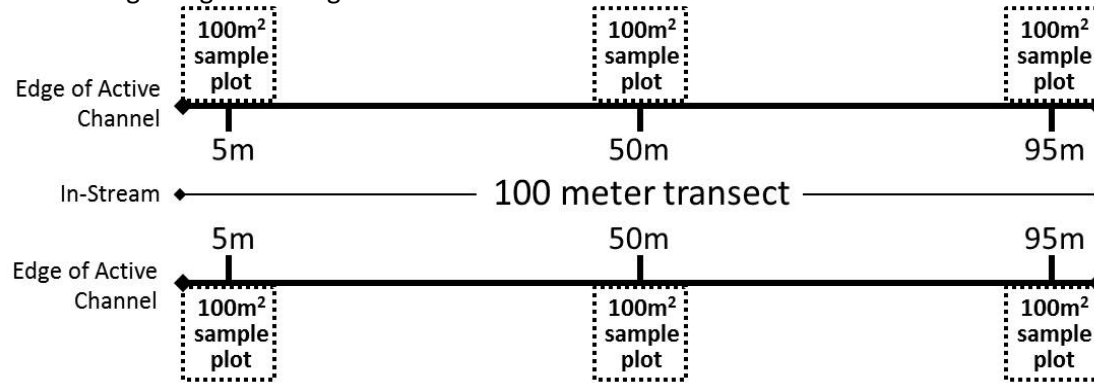

Riparian Zone

Gap Frequency: Along the entire 100 meter longitudinal transect, estimate the relative frequency of riparian buffer gaps on both sides of the creek (for a total of 200 possible meters). A riparian buffer gap is defined as a void in vegetation ≥ 1 meter wide where surface runoff has an unimpeded path to the stream channel. An unimpeded path exists if no vegetation higher than 12 inches is present. Woody vegetation must consist of a multi-stemmed trunk with a total diameter of ≥ 5 inches or a single trunk with a diameter of ≥ 5 inches in order to be considered as impeding the flow path. Tally all 1 meter buffer gaps along both banks of the 100 meter transect and divide by 200 then multiply by 100 to obtain an overall percentage for the transect.

Large Woody Debris: Along the entire 100 meter transect, record the number of large woody debris pieces observed. Large woody debris is defined as wood that is fully or partially exposed and is at least 6 inches in diameter and 3 feet in length.

Soil Compaction: In the center of each 100 square meter sample plot, position the tip of the soil compaction meter on the ground. Apply even downward pressure on both handles at a slow, even pace and record the gauge reading at a depth of 3 inches. A total of three measurements should be taken from each plot. Average all the readings from the six sample plots to calculate the overall score.

Structural Diversity: Within each 100 square meter sample plot, estimate the percent cover of the canopy and understory vegetation layers by using the shadow cast by each particular layer. The canopy layer is > 5 meters high and the understory is 0.5 to 5 meters high. The surveyors should walk the sample plot, focusing on one vegetation category at a time and then agree on one value to record. To help obtain an accurate estimate, run a measuring tape to better define the study area or divide the sample plot into smaller units. Average the percentages from the six sample plots to calculate the overall score.

Methodology: Zone 3 – Active Channel

Tree Demography: Within each 100 square meter sample plot, record the species of the canopy trees present and then record the presence or absence of canopy woody species at multiple age classes (seedlings, saplings, mature, and snags). See reference list of canopy woody species in Zone 1 Methodology. Seedlings are defined as 12 inches or less, having sprouted within the last year. Saplings are > 12 inches in height, but have yet to reach half their mature height and lack a fully-developed canopy. Mature trees are approaching their maximum height and display a fully-developed canopy. Snags are standing dead trees with little to no vegetation and reduced canopy coverage. Average the number of age classes observed from the six sample plots to calculate the overall score.

Wetland Tree Status: Within each 100 square meter sample plot, perform a brief inventory of tree species composition and abundance. Verify the wetland status of each taxa and convert to a percent of total trees that are FAC+ or greater (FAC+, FACW-, FACW, FACW+, and OBL) with respect to wetland indicator status (i.e. number of FAC+ or greater trees / total number of trees present). See reference list of FAC+ or greater tree species in Zone 2 Methodology. Average the percentages from the six sample plots to calculate the overall score.

Riparian Zone Width: At 5, 50, and 95 meters along the transect, run a measuring tape from the edge of active channel perpendicular away from the stream channel to the edge of the undisturbed riparian vegetation or the end of the Critical Water Quality Zone, whichever comes first. The edge of the riparian zone buffer is often dictated by a human structure (house, fence, road) or management activity (agriculture, mowing) that inhibits plant growth and alters the availability of the soil and vegetation to filter surface runoff. Average the measurements from the six locations to calculate the overall score.

In-Stream Canopy Cover: Take a densiometer measurement at 5, 50, and 95 meters along the transect. Facing downstream, hold the densiometer level 12 to 18 inches in front of the body so the operator's head is just outside of the grids. Count the number of quarter squares not occupied by vegetation. Multiply the total count by 1.04 and subtract from 100 to obtain percent canopy cover. Average the percentages from the three locations to calculate the overall score.

Geomorphology

Mass Wasting: Along each 100 meter transect, perform a visual observation that evaluates the existing and the potential for future major bank sloughing within the reach.

Bank Protection: Along each 100 meter transect, perform a visual observation that evaluates the amount and variety of vegetation covering the channel banks within the stream reach.

Obstructions, Deflectors, Sediment Traps: Along each 100 meter transect, perform a visual observation that evaluates the presence of obstructions, deflectors, and sediment traps within the reach and of its relative permanence in the channel.

Undercutting: Along each 100 meter transect, perform a visual observation that evaluates the prevalence and the height of cut and raw banks along the channel reach.

Deposition: Along each 100 meter transect, perform a visual observation that evaluates the amount of recent deposition of sediments in the reach resulting in new in-stream features such as bars or filled-in pools.

Consolidation or Particle Packing: Along each 100 meter transect, perform a visual observation that evaluates the degree to which stream bed particles are stabilized in the bed, either due to embeddedness or the orientation of the particles.

Scouring and Deposition: Along each 100 meter transect, perform a visual observation that evaluates the extent of bed material mobilization within the reach, evidenced by scouring and/or deposition.

Methodology: Zone 3 – Active Channel

Entrenchment Ratio: At a reference site along each 100 meter transect, measure the width of the floodprone area, bankfull channel width, and bankfull depth. Calculate the entrenchment ratio by dividing the floodprone width (channel width at 2 times the bankfull depth) by the width of the bankfull channel.

Measurement of Entrenchment Ratio (ER) at a Cross Section

$$ER = \text{Floodprone Width (FW)} / \text{Bankfull Width (BW)}$$

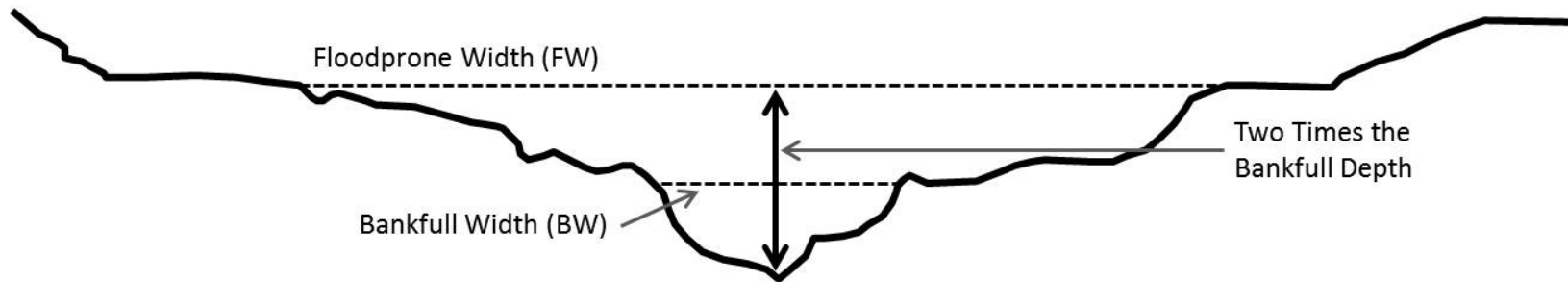

Floodplain Connectivity/Bank Height Ratio: Within each 100 meter transect, measure the bankfull depth and topographic low bank height. Estimate the bank height ratio by dividing the height of the low bank by the bankfull depth.

Measurement of Bank Height Ratio (BHR) at a Cross Section

BHR = 1.0 (Excellent)

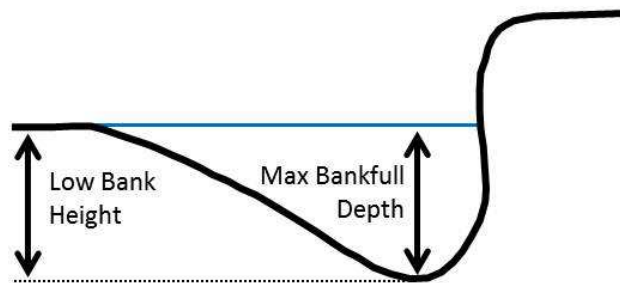

BHR = 1.63 (Fair)

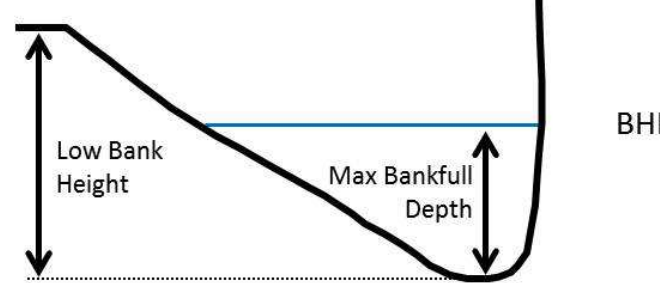

$$BHR = \frac{\text{Low Bank Height}}{\text{Max Bankfull Depth}}$$

Exposed Infrastructure: Along each 100 meter transect, perform a visual observation that determines if exposed infrastructure such as footings or pipes is evident.

Evidence of Headcuts: Along each 100 meter transect, perform a visual observation that determines if headcuts are evident. A headcut (also known as a

knickpoint) is an erosional feature where an abrupt vertical drop in the stream bed occurs.

Methodology: Zone 3 – Active Channel

Aquatic Habitat

Epifaunal Substrate and Available Cover: Along each 100 meter transect, perform a visual observation that evaluates the channel substrate, snags, submerged logs, and other stable habitat features to determine the amount of habitat available for epifaunal community colonization.

Embeddedness: Along each 100 meter transect, perform a visual observation that evaluates the degree to which gravel, cobble, and boulder particles are surrounded by fine sediments.

Velocity/Depth Regimes: Along each 100 meter transect, perform a visual observation that evaluates the presence of four categories of regimes: slow-deep, slow-shallow, fast-deep, and fast-shallow. Highest scores are assigned to reaches with all four velocity/depth regimes.

Sediment Deposition: Along each 100 meter transect, perform an assessment that evaluates the degree to which in-stream features are enlarging, with areas with less than 5 percent of the reach affected by deposition receiving the highest scores.

Frequency of Riffles: Along each 100 meter transect, perform an assessment that evaluates the occurrence of riffles, with reaches in which the average distance between riffles is less than seven times the channel's bankfull width receiving the highest scores.

Flow Permanence Score: For each 100 meter transect, utilize the flow permanence score calculated for the proximate Environmental Integrity Index (EII) reach. (Use <http://www.austintexas.gov/GIS/FindYourWatershed/> to find the EII reach name and consult the table of corresponding scores below.) Confirm in the field with a visual observation that evaluates the potential indicators of wetland and/or ephemeral status.

Flow Permanence Scores by EII Reach

EII Reach	Score	EII Reach	Score	EII Reach	Score	EII Reach	Score	EII Reach	Score
BAR1	69.8	BUL4	86.8	GIL1	90.9	MAR2	18	SLA2	37.5
BAR2	77.8	BUL5	94.7	GIL2	90.6	NFD1	19.6	SLA3	60.3
BAR3	88	CAR1	89.2	GIL3	90.4	ONI1	91.2	TAN1	63.4
BAR4	76.4	CAR2	65.3	GIL4	50	ONI2	91.3	TAN2	69.7
BAR5	81.2	CCE1	15.6	GIL5	90.6	ONI3	93	TAN3	76.5
BAR6	76.3	CCW1	26.4	GIL6	90.6	ONI4	94.2	TRK1	32.5
BEE1	72.2	CCW2	68.1	HRP1	77.2	ONI4a	68.1	TYN1	55.5
BEE2	46	CMF1	35.2	HRS1	79.6	ONI5	80.8	TYS1	89.6
BEE3	85.2	CRN1	28.1	HRS2	77.6	ONI6	76.8	WBL1	69.3
BER1	47.4	CTM1	32.6	JOH1	66.4	PAN1	49.5	WBL2	80.1
BER2	17.7	DKR1	65.7	LBA1	80.4	RAT1	30.2	WBO1	11.5
BER3	64.9	DKR3	36.7	LBA2	71.3	RAT2	36.4	WBO2	62.5
BLU1	93.6	DRE1	38.6	LBA3	62.7	RDR1	72.6	WBO3	43.7
BLU2	75.8	DRE2	32.8	LBE1	28.5	RIN1	88.6	WLN1	87.3
BLU3	70.6	DRN1	83.8	LBR1	48.7	RIN2	29.1	WLN2	88.3
BMK1	91.2	DRN2	80.5	LBR2	52	RIN3	13.3	WLN3	89.3
BMK2	34.8	EAN1	14.8	LKA	78.2	SBG1	67.6	WLN4	76.6
BMK3	40.6	EAN2	68.1	LKC1	79	SBG2	62	WLN5	87.3
BOG1	58.5	EBO1	81.9	LKC2	81.2	SFD1	45.2	WLR1	97
BOG2	84.3	EBO2	74.8	LKC3	89.5	SFD2	18.2	WLR2	89.8
BOG3	62.2	EBO3	47	LWA1	95.2	SHL1	97	WLR3	83.9
BRW1	71.8	ELM2	19.2	LWA2	84.7	SHL2	79.8	WMS1	92.2
BUL1	93	FOR2	20.4	LWA3	79.5	SHL3	74	WMS2	26.4
BUL2	87.6	FOR3	53.3	LWA4	75	SHL4	61.1	WMS3	29.2

BUL3	85.5	FOR4	75.7	MAR1	83.3	SLA1	74.1	WMS3	29.2
------	------	------	------	------	------	------	------	------	------

Field Sheet: Zone 3 – Active Channel

Riparian Zone

Site/Project Name: _____

Date: _____

Time: _____

Transect Number: _____

Staff (if applicable): _____

Gap Frequency

Number of 1 meter gaps (right bank): _____

Number of 1 meter gaps (left bank): _____

Percent of Transect: _____ %

Large Woody Debris

Number of Large Woody Debris Pieces: _____

Soil Compaction

Plot 1 (5 meters) – Right Bank #1: _____ psi #2: _____ psi #3: _____ psi Average for Plot 1: _____ psi	Plot 2 (50 meters) – Right Bank #1: _____ psi #2: _____ psi #3: _____ psi Average for Plot 2: _____ psi	Plot 3 (95 meters) – Right Bank #1: _____ psi #2: _____ psi #3: _____ psi Average for Plot 3: _____ psi
Plot 4 (5 meters) – Left Bank #1: _____ psi #2: _____ psi #3: _____ psi Average for Plot 1: _____ psi	Plot 5 (50 meters) – Left Bank #1: _____ psi #2: _____ psi #3: _____ psi Average for Plot 2: _____ psi	Plot 6 (95 meters) – Left Bank #1: _____ psi #2: _____ psi #3: _____ psi Average for Plot 3: _____ psi

Average for All Sample Plots: _____ psi

Structural Diversity

Plot 1 (5 meters) – Right Bank Canopy: _____ % Understory: _____ %	Plot 2 (50 meters) – Right Bank Canopy: _____ % Understory: _____ %	Plot 3 (95 meters) – Right Bank Canopy: _____ % Understory: _____ %
Plot 4 (5 meters) – Left Bank Canopy: _____ % Understory: _____ %	Plot 5 (50 meters) – Left Bank Canopy: _____ % Understory: _____ %	Plot 6 (95 meters) – Left Bank Canopy: _____ % Understory: _____ %

Average for All Sample Plots: Canopy: _____ % Understory: _____ %

Field Sheet: Zone 3 – Active Channel

Riparian Zone

Site/Project Name: _____

Date: _____ Time: _____

Transect Number: _____

Staff (if applicable): _____

Tree Demography

Plot 1 (5 meters) – Right Bank	Plot 2 (50 meters) – Right Bank	Plot 3 (95 meters) – Right Bank
Number of Age Classes: _____	Number of Age Classes: _____	Number of Age Classes: _____
Plot 4 (5 meters) – Left Bank	Plot 5 (50 meters) – Left Bank	Plot 6 (95 meters) – Left Bank
Number of Age Classes: _____	Number of Age Classes: _____	Number of Age Classes: _____

Average for All Sample Plots: _____

Wetland Tree Status

Plot 1 (5 meters) – Right Bank	Plot 2 (50 meters) – Right Bank	Plot 3 (95 meters) – Right Bank
Number of FAC+ or Greater Trees: _____ Total Number of Trees: _____ Percent FAC+ or Greater: _____%	Number of FAC+ or Greater Trees: _____ Total Number of Trees: _____ Percent FAC+ or Greater: _____%	Number of FAC+ or Greater Trees: _____ Total Number of Trees: _____ Percent FAC+ or Greater: _____%
Plot 4 (5 meters) – Left Bank	Plot 5 (50 meters) – Left Bank	Plot 6 (95 meters) – Left Bank
Number of FAC+ or Greater Trees: _____ Total Number of Trees: _____ Percent FAC+ or Greater: _____%	Number of FAC+ or Greater Trees: _____ Total Number of Trees: _____ Percent FAC+ or Greater: _____%	Number of FAC+ or Greater Trees: _____ Total Number of Trees: _____ Percent FAC+ or Greater: _____%

Average for All Sample Plots: _____%

Field Sheet: Zone 3 – Active Channel

Site/Project Name: _____

Transect Number: _____

Riparian Zone

Date: _____

Time: _____

Staff (if applicable): _____

Riparian Zone Width

<p>Measurement 1 (5 meters) – Right Bank</p> <p>Riparian Zone Width: _____ m</p>	<p>Measurement 2 (50 meters) – Right Bank</p> <p>Riparian Zone Width: _____ m</p>	<p>Measurement 3 (95 meters) – Right Bank</p> <p>Riparian Zone Width: _____ m</p>
<p>Measurement 4 (5 meters) – Left Bank</p> <p>Riparian Zone Width: _____ m</p>	<p>Measurement 5 (50 meters) – Left Bank</p> <p>Riparian Zone Width: _____ m</p>	<p>Measurement 6 (95 meters) – Left Bank</p> <p>Riparian Zone Width: _____ m</p>

Average for All Measurements: _____ m

In-Stream Canopy Cover

<p>Measurement 1 (5 meters)</p> <p>Quarter Squares Not Occupied: _____</p> <p>100 – (Count x 1.04): _____ %</p>	<p>Measurement 2 (50 meters)</p> <p>Quarter Squares Not Occupied: _____</p> <p>100 – (Count x 1.04): _____ %</p>	<p>Measurement 3 (95 meters)</p> <p>Quarter Squares Not Occupied: _____</p> <p>100 – (Count x 1.04): _____ %</p>
--	---	---

Average for All Measurements: _____ %

Field Sheet: Zone 3 – Active Channel

Geomorphology

Site/Project Name: _____

Date: _____

Time: _____

Transect Number: _____

Staff (if applicable): _____

Entrenchment Ratio (ER)

Width of Floodprone Area: _____ m

Bankfull Channel Width: _____ m

Bankfull Depth: _____ m

ER = Floodprone Width / Bankfull Width = _____

Measurement of Entrenchment Ratio (ER) at a Cross Section

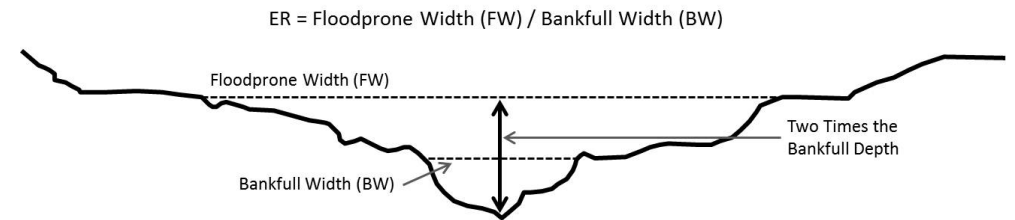

Bank Height Ratio (BHR)

Bankfull Depth: _____ m

Low Bank Height: _____ m

BHR = Low Bank Height / Bankfull Depth = _____

Measurement of Bank Height Ratio (BHR) at a Cross Section

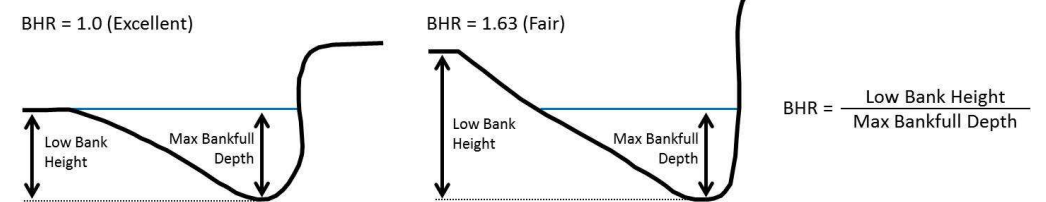

Note: There is no field sheet for Aquatic Habitat.

Scoring: Zone 4 – Lake Shoreline

Site/Project Name: _____

Date: _____ Time: _____

Total Length of Shoreline Frontage (in feet): _____

Staff (if applicable): _____

Parameter	Excellent (4)	Good (3)	Fair (2)	Poor (1)	Score
Gap Frequency <i>A visual assessment of the number of gaps in vegetation.</i>	0 - 20% of area has visual gaps in vegetation	20% - 40% of area has visual gaps in vegetation	40 - 60% of area has visual gaps in vegetation	> 60% of area has visual gaps in vegetation	
Structural Diversity <i>An evaluation of the canopy and understory vegetation.</i>	> 65% canopy; or > 50% canopy and > 50% understory	51 - 65% canopy; or 0 - 50% canopy and > 40% understory	31 - 50% canopy; or 0 - 30% canopy and > 30% understory	0 - 30% canopy; or 0 - 15% canopy and 0 - 30% understory	
Tree Demography <i>An assessment of the age class distribution of all canopy tree species.</i>	Canopy tree species are present in all 4 age classes	Canopy tree species are present in 3 of 4 age classes	Canopy tree species are present in 2 of 4 age classes	Canopy tree species are present in only 1 age class or no trees	

Zone 4 Score: _____

Assessed Condition (Circle One)

Excellent: 11 - 12

Good: 8 - 10

Fair: 5 - 7

Poor: 3 - 4

Methodology: Zone 4 – Lake Shoreline

Establishing Sample Areas: The entire shoreline frontage of the lot to a depth of 7.6m (25ft) landward from the shoreline shall be the sample area. The number of sample plots in the sample area shall equal the maximum number of whole 7.6m x 7.6m sample plots that fit in the available space. To determine the number of plots, simply divide the linear distance of lot shoreline frontage (in feet) by the number 25 and round down to the nearest whole number.

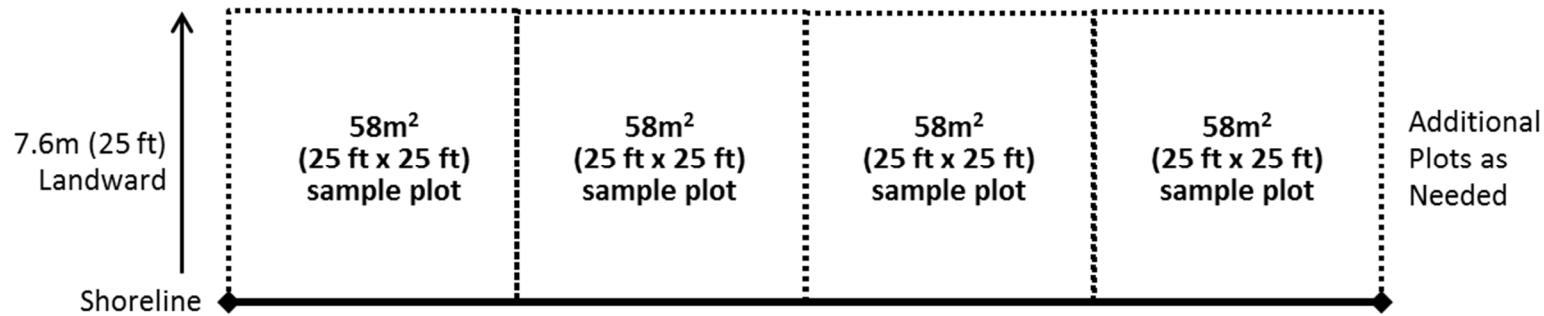

Gap Frequency: Along the entire shoreline frontage transect, estimate the relative frequency of vegetative buffer gaps observed within 10 meters upslope of the transect. A vegetative buffer gap is defined as a void in vegetation ≥ 1 meter wide where surface runoff has an unimpeded path toward the stream channel. An unimpeded path exists if no vegetation higher than 12 inches is present. Woody vegetation must consist of a multi-stemmed trunk with a total diameter of ≥ 5 inches or a single trunk with a diameter of ≥ 5 inches in order to be considered as impeding the flow path. Tally all 1 meter buffer gaps along the shoreline transect and divide by the entire length of the transect to calculate the overall percentage.

Structural Diversity: Use a measuring tape to define the study area. Within each 7.6 square meter sample plot, estimate the percent cover of the canopy and understory vegetation layers by estimating the "shadow" cast by each particular layer. The canopy layer is > 5 meters high and the understory is 0.5 to 5 meters high. Average the percentages for canopy and understory from all sample plots to calculate the overall score.

Tree Demography: Within each 7.6 m x 7.6 m sample plot, record the species of canopy trees present and then record the presence or absence of canopy woody species at multiple age classes (seedlings, saplings, mature, and snags). See reference list of canopy woody species in Zone 4 Methodology. Seedlings are defined as 12 inches or less, having sprouted within the last year. Saplings are > 12 inches in height, but have yet to reach half their mature height and lack a fully-developed canopy. Mature trees are approaching their maximum height and display a fully-developed canopy. Snags are standing dead trees with little to no vegetation and reduced canopy coverage. Average the number of age classes observed from all sample plots to calculate the overall score.

Methodology: Zone 4 – Lake Shoreline

Reference List of Canopy Woody Species

(Common Canopy Species and Significant Shade Providers from ECM Appendix F: Descriptive Categories of Tree Species)

Common Name	Scientific Name	Common Name	Scientific Name
Anacua	<i>Ehretia anacua</i>	Oak, Bur	<i>Quercus macrocarpa</i>
Ash, Green	<i>Fraxinus pennsylvanica</i>	Oak, Chinquapin	<i>Quercus muehlenbergii</i>
Bois D'Arc	<i>Maclura pomifera</i>	Oak, Durand	<i>Quercus sinuata var. sinuata</i>
Boxelder	<i>Acer negundo</i>	Oak, Lacey	<i>Quercus laceyi</i>
Bumelia, Gum	<i>Sideroxylon lanuginosum</i>	Oak, Live (Coastal)	<i>Quercus virginiana</i>
Catalpa	<i>Catalpa spp.</i>	Oak, Live (Plateau)	<i>Quercus fusiformis</i>
Cedar, Eastern Red	<i>Juniperus virginiana</i>	Oak, Mexican White	<i>Quercus polymorpha</i>
Cherry, Escarpment Black	<i>Prunus serotina var. eximia</i>	Oak, Post	<i>Quercus stellata</i>
Cherry-Laurel, Carolina	<i>Prunus caroliniana</i>	Oak, Shin	<i>Quercus sinuata var. breviloba</i>
Cottonwood, Eastern	<i>Populus deltoides</i>	Oak, Shumard Red	<i>Quercus shumardii</i>
Cypress, Arizona	<i>Cupressus arizonica</i>	Oak, Texas Red	<i>Quercus texana</i>
Cypress, Bald	<i>Taxodium distichum</i>	Pecan	<i>Carya illinoensis</i>
Cypress, Montezuma	<i>Taxodium mucronatum</i>	Persimmon, Common	<i>Diospyros virginiana</i>
Elm, American	<i>Ulmus Americana</i>	Pistache, Texas	<i>Pistacia texana</i>
Elm, Cedar	<i>Ulmus crassifolia</i>	Soapberry	<i>Sapindus drummondii</i>
Hackberry	<i>Celtis spp.</i>	Sycamore, American	<i>Platanus occidentalis</i>
Hickory, Mockernut	<i>Carya alba</i>	Sycamore, Mexican	<i>Platanus mexicana</i>
Juniper, Ashe	<i>Juniperus ashei</i>	Walnut, Arizona	<i>Juglans major</i>
Magnolia, Southern	<i>Magnolia grandiflora</i>	Walnut, Eastern Black	<i>Juglans nigra</i>
Maple, Bigtooth	<i>Acer grandidentatum</i>	Walnut, Little	<i>Juglans microcapra</i>
Oak, Blackjack	<i>Quercus marilandica</i>	Willow, Black	<i>Salix nigra</i>

Field Sheet: Zone 4 – Lake Shoreline

Site/Project Name: _____

Date: _____ Time: _____

Total Length of Shoreline Frontage (in feet): _____

Total Number of Plots*: _____

Staff (if applicable): _____

*To determine the total number of plots, divide the linear distance of shoreline (in feet) by the number 25 and round down to the nearest whole number. Record the data below for each of the consecutive plots in the sample area, crossing out the extra spaces as necessary. For lots with greater than 174 linear feet of shoreline, attach additional sheets and average all plots.

Gap Frequency

Number of 1 meter gaps: _____

Percent of Transect: _____ %

Structural Diversity

<u>Plot 1</u>	<u>Plot 2</u>	<u>Plot 3</u>	<u>Plot 4</u>	<u>Plot 5</u>	<u>Plot 6</u>
Canopy: _____ %	Canopy: _____ %	Canopy: _____ %	Canopy: _____ %	Canopy: _____ %	Canopy: _____ %
Understory: _____ %	Understory: _____ %	Understory: _____ %	Understory: _____ %	Understory: _____ %	Understory: _____ %

Average for percent cover for all Sample Plots: Canopy: _____ % Understory: _____ %

Tree Demography

<u>Plot 1</u>	<u>Plot 2</u>	<u>Plot 3</u>	<u>Plot 4</u>	<u>Plot 5</u>	<u>Plot 6</u>
Number of Age Classes: _____	Number of Age Classes: _____	Number of Age Classes: _____	Number of Age Classes: _____	Number of Age Classes: _____	Number of Age Classes: _____

Average age classes for all Sample Plots: _____

References

Barbour, M.T., J. Gerritsen, B.D. Snyder, and J.B. Stribling. 1999. Rapid Bioassessment Protocols for Use in Streams and Wadeable Rivers: Periphyton, Benthic Macroinvertebrates and Fish, Second Edition. EPA 841-B-99-002. U.S. Environmental Protection Agency; Office of Water; Washington, D.C.

<http://water.epa.gov/scitech/monitoring/rsi/bioassessment/index.cfm>

Harman, W., R. Starr, M. Carter, K. Tweedy, M. Clemmons, K. Suggs, C. Miller. 2012. A Function-Based Framework for Stream Assessment and Restoration Projects. US Environmental Protection Agency, Office of Wetlands, Oceans, and Watersheds, Washington, DC. EPA 843-K-12-006.

http://water.epa.gov/lawsregs/guidance/wetlands/upload/A_Function-Based_Framework-2.pdf

Pfankuch, D. J. 1975. Stream reach inventory and channel stability evaluation. U.S. Department of Agriculture Forest Service. Region 1. Missoula, Montana.

Richter, F.A. and A. Duncan. 2012. Riparian Functional Assessment: Choosing Metrics that Quantify Restoration Success in Austin, Texas. City of Austin, Watershed Protection Department, Environmental Resource Management. SR-12-12.