

**RULE NO.: R161-24.05****ADOPTION DATE: 05/08/24****NOTICE OF RULE ADOPTION**

By: Jorge L. Morales, P.E., CFM, Director  
Watershed Protection Department

The Director of the Watershed Protection Department has adopted the following rule. Notice of the proposed rule was posted on 03/28/24. Public comment on the proposed rule was solicited in the 03/28/24 notice. This notice is issued under Chapter 1-2 of the City Code. The adoption of a rule may be appealed to the City Manager in accordance with Section 1-2-10 of the City Code as explained below.

A copy of the complete text of the adopted rule is attached to this notice.

**EFFECTIVE DATE OF ADOPTED RULE**

A rule adopted by this notice is effective on 05/08/24.

**TEXT OF ADOPTED RULE**

The adopted rule contains no changes from the proposed rule as shown below.

R161-24.05: Modifies the Environmental Criteria Manual as follows:

- 1.6.2 B Water Quality Volume Diversion Structures – Clarification of Rainwater Harvesting controls and the Onsite Water Reuse Systems Ordinance of Chapter 15-13 of the City of Austin Code.
- 1.6.7- Green Stormwater Quality Infrastructure – Provide additional options for stormwater control through rainwater harvesting. Change includes definitions of the two approaches to rainwater harvesting, clarification of which LDC sections govern permitting and design requirements for each, and outlines how stormwater quality credit can be obtained for each.
- Appendix R-7 – Provides calculation for Development Permits for Type IIA Rainwater Harvesting Systems which provide 1 inch of capture depth off of rooftops and are outside of the Barton Springs Zone.

**SUMMARY OF COMMENTS**

The Watershed Protection Department did not receive comments regarding the rule adopted in this notice.

**AUTHORITY FOR ADOPTION OF RULE**

The authority and procedure for the adoption of a rule to assist in the implementation, administration, or enforcement of a provision of the City Code is established in Chapter 1-2 of the City Code. The authority to regulate water quality is established in Chapter 25-8 of the City Code.

**APPEAL OF ADOPTED RULE TO CITY MANAGER**

A person may appeal the adoption of a rule to the City Manager. **AN APPEAL MUST BE FILED WITH THE CITY CLERK NOT LATER THAN THE 30TH DAY AFTER THE DATE THIS NOTICE OF RULE ADOPTION IS POSTED. THE POSTING DATE IS NOTED ON**

**THE FIRST PAGE OF THIS NOTICE.** If the 30th day is a Saturday, Sunday, or official city holiday, an appeal may be filed on the next day which is not a Saturday, Sunday, or official city holiday.

An adopted rule may be appealed by filing a written statement with the City Clerk. A person who appeals a rule must (1) provide the person’s name, mailing address, and telephone number; (2) identify the rule being appealed; and (3) include a statement of specific reasons why the rule should be modified or withdrawn.

Notice that an appeal was filed and will be posted by the city clerk. A copy of the appeal will be provided to the City Council. An adopted rule will not be enforced pending the City Manager’s decision. The City Manager may affirm, modify, or withdraw an adopted rule. If the City Manager does not act on an appeal on or before the 60th day after the date the notice of rule adoption is posted, the rule is withdrawn. Notice of the City Manager’s decision on an appeal will be posted by the city clerk and provided to the City Council.

On or before the 16th day after the city clerk posts notice of the City Manager’s decision, the City Manager may reconsider the decision on an appeal. Not later than the 31st day after giving written notice of an intent to reconsider, the City manager shall make a decision.

**CERTIFICATION BY CITY ATTORNEY**

By signing this Notice of Rule Adoption (R161-24.05), the City Attorney certifies that the City Attorney has reviewed the rule and finds that adoption of the rule is a valid exercise of the Director’s administrative authority.

**REVIEWED AND APPROVED**

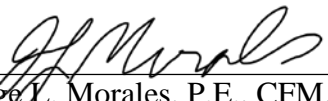
  
\_\_\_\_\_  
Jorge L. Morales, P.E., CFM, Director  
Watershed Protection Department

Date: 04/26/2024

*Anne L. Morgan*  
\_\_\_\_\_  
Anne L. Morgan  
City Attorney

Date: 5/5/24

## 1.6.2 General Design Guidelines

### B. Water Quality Volume Diversion Structures.

2. SCMs that are allowed to stack the required detention volume or allow all storm events to flowthrough the SCM above the water quality volume are as follows:
  - Partial sedimentation with sand filtration or biofiltration controls
  - Full sedimentation with sand filtration or biofiltration controls
  - Retention Irrigation controls that are not subject to compliance with the SOS ordinance.
  - Rainwater Harvesting controls [that are not subject to compliance with the Onsite Water Reuse Systems Ordinance of Chapter 15-13 of the City of Austin Code.](#)
  - Rain Gardens
  - Porous Pavement

In-line SCMs that propose to stack the required detention volume or allow all storm events to flow through the SCM above the water quality volume must comply with the following criteria:

- a) The velocity of the flows entering the SCM for the developed 100 year peak flow must not exceed two feet per second.
- b) Velocity breaks and energy dissipation should be incorporated into the design to reduce erosive impacts on the SCM and to protect the medium (sand or biofiltration) from washingout or eroding.
- c) Detention pond and SCM wall elevations must meet the minimum freeboard requirements provided in the Drainage Criteria Manual.

## 1.6.7 Green Storm Water Quality Infrastructure

### 1.6.7.2 Water Quality Credit

The water quality credit system presented in this section sets forth a method for designers to achieve full credit or partial credit for innovative controls that are either undersized or capture runoff from only a portion of the developed site. The objective of the water quality credit system is to provide flexibility for meeting the City's water quality requirements. For example, in many cases full water quality credit can be met through the use of a single control located at the downstream end of the developed site. Alternatively, water quality credit can be achieved through green stormwater quality infrastructure controls distributed throughout a developed site and integrated into the landscape. [Water quality credit can also be accrued for the drainage area with Rainwater Harvesting \(RWH\) systems that capture and beneficially reuse water on-site.](#) The remaining required water quality volume that is not treated with Section 1.6.7 controls must be treated using other controls approved in the Environmental Criteria Manual.

The amount of credit for the practices described below can be applied as either a reduction in the size of a water quality control or, in Urban Watersheds, a reduction in the payment instead of structural controls.

The basic credit equation is:

$$WQC = IAF * BMPDF \text{ (Equation 1.6.7-1)}$$

Where

- WQC = Water Quality Credit, a value between 0 and 1, with 1 meaning 100% credit;
- IAF = Impervious Area Factor, or the fraction of total impervious area treated by the control; and
- BMPDF = Best management practice (BMP) Design Factor, a measure of the degree of design equivalency with sedimentation-filtration systems. Values are on a scale of 0 to 1, with 1 meaning 100% credit.

For two of the practices, porous pavement for pedestrian use and non-required vegetation, the water quality credit is applied as a deduction in the drainage area for sizing water quality controls, as described in the subsections below.

For vegetated pond-type controls, which include biofiltration and rain garden controls, the BMPDF factor is based on the following factors:

$WQV_{bmp}$  = water quality capture depth provided by the BMP in inches, and  $WQV_{ecm}$  = ECM required water quality capture depth in inches.

Specific drawdown time requirements for vegetated pond-type controls are described below in respective subsections for each control. The BMPDF for vegetated pond-type shall be determined using Figure 1.6.7-1 below.

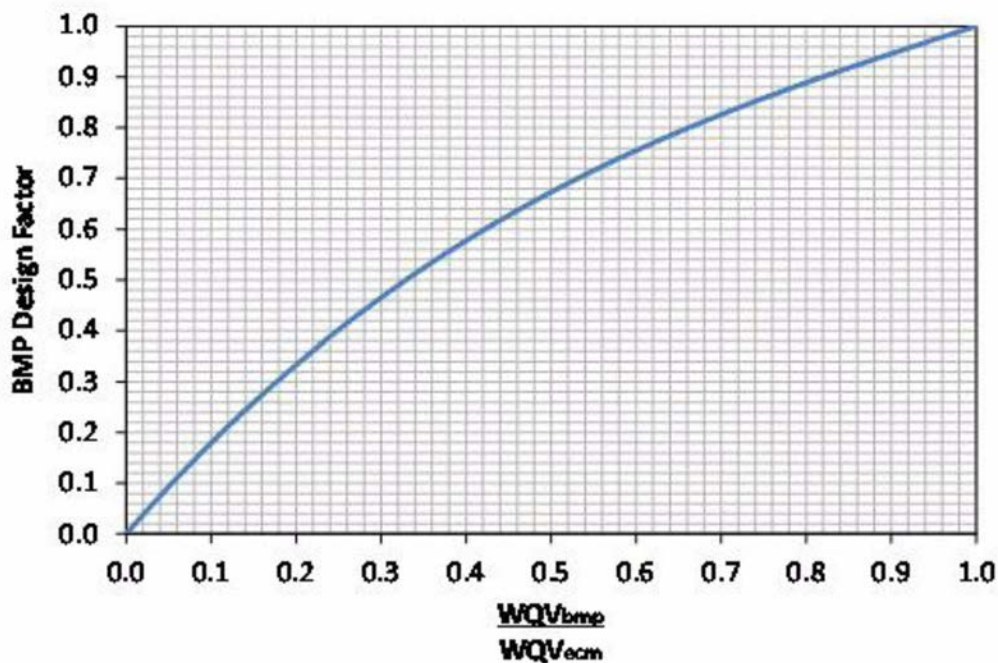

For Rainwater Harvesting systems, the BMPDF is a function of water quality capture depth and drawdown time depends on the type of system, the size of the tank, and how quickly the tank is emptied as described in 1.6.7.D.

For Vegetative Filter Strips (VFS) the water quality credit is a function of percent infiltration and hydraulic loading rate as described in 1.6.7.B.

Credit may be restricted or disallowed in some cases for watersheds in the Barton Springs Contributing and Recharge Zones as described below in the subsections for each control.

### 1.6.7.D. Rainwater Harvesting

1. Introduction. Rooftops can generate large volumes of runoff which, when discharged to paved surfaces and landscaped areas, can generate large pollutant loads. Rainwater Harvesting (RWH) systems can capture this runoff before it is discharged, thus preventing pollution while also putting the captured water to beneficial use, such as landscape irrigation, toilet flushing, or cooling water. In acknowledgement of the pollutant load removal provided by RWH, commercial developments that comply with and implement RWH as required by Chapter 15-13 shall be allowed a stormwater quality "credit" which would allow developers to reduce the size of their water quality ponds by a specified amount in the drainage area where the RWH system is located. The amount of runoff captured over the long-term, and thus the allowed stormwater credit will depend on the size volume of the cistern (water quality volume) and drawdown time of the rainwater harvesting system rate at which the cistern empties. *[Propose end Paragraph here]*

There are two types of RWH systems for the purposes of determining water quality credit. Type I systems generally are designed for stormwater control with ancillary potable water offset benefit. Type II systems are designed primarily for potable water offset with ancillary stormwater control. Both systems will be permitted for commercial developments and multifamily residential developments.

For the purposes of calculating water quality credit, the RWH system types are defined as follows:

- A. Type I – a RWH system in which the collection cistern has a maximum drawdown time of 120 hours. These can be either gravity drained (Type IA) or pumped (Type IB) to an infiltration area. These systems are prohibited from having a potable water supply connection.
- B. Type II – a RWH system in which the collection cistern empties as stored water is used to meet onsite demand. Type II systems are designed and permitted in accordance with Chapter 15-13 of the Code of Ordinances (Onsite Water Reuse) and will have potable back up water to supply demands when there is no rainwater available. For the purpose of calculating the stormwater credit, Type II RWH systems are further defined as follows:
  - Type IIA – a Type II system with a 1-inch capture depth and is located outside the Barton Springs Zone. This type allows a streamlined water quality crediting approach.
  - Type IIB – a Type II system with a custom-sized collection cistern and/or is located inside the Barton Springs Zone. This type requires site-specific engineering analysis to obtain water quality credit.

The Type I and Type II systems can also control the peak flow rate for the 2-year storm. See Section 1.6.8 if specifically designed for this purpose. Rainwater harvesting Type I RWH systems can provide equivalent treatment to a standard sedimentation/filtration system and may be used within the Barton Springs Zone if the design achieves the non-degradation load requirements detailed in Section 1.6.9. Rainwater Harvesting Type I and II RWH systems will only be permitted for commercial developments. All systems with pumps (whether Type I or Type II systems) are subject to cross-connection testing in accordance with Chapters 15-1 (Cross Connection Regulations) and 25-12 (Technical Codes).

In an effort to promote water conservation, the State of Texas offers financial incentives and tax exemptions to offset the equipment costs. Additionally, the Water Conservation staff of the City of Austin Water Utility Department is available to provide input on how to achieve cost efficient design and equipment selection that will also help reduce water and

wastewater costs.

2. Water Quality Credit.

The water quality credit will typically be applied as either a reduction in the water quality volume for a structural control or a reduction in the payment fee-in-lieu cost. The basic water quality credit equation is calculated using Equation 1.6.7-1.

A. Water Quality Credit for Type I rainwater harvesting systems.

For **rainwater harvesting Type I RWH** systems, the **BMP Design Factor (BMPDF)** variable is a function of the following factors:

- $WQV_{rwh}$  is the water quality capture depth provided by the rainwater harvesting system in inches,
- $WQV_{ecm}$  is the ECM required water quality capture depth in inches, and
- $DDT_{rwh}$  is the rainwater harvesting system drawdown time in hours (a maximum of 120 hrs.). The BMPDF **for Type I systems** shall be determined using Figure 1.6.7.D-1 below:

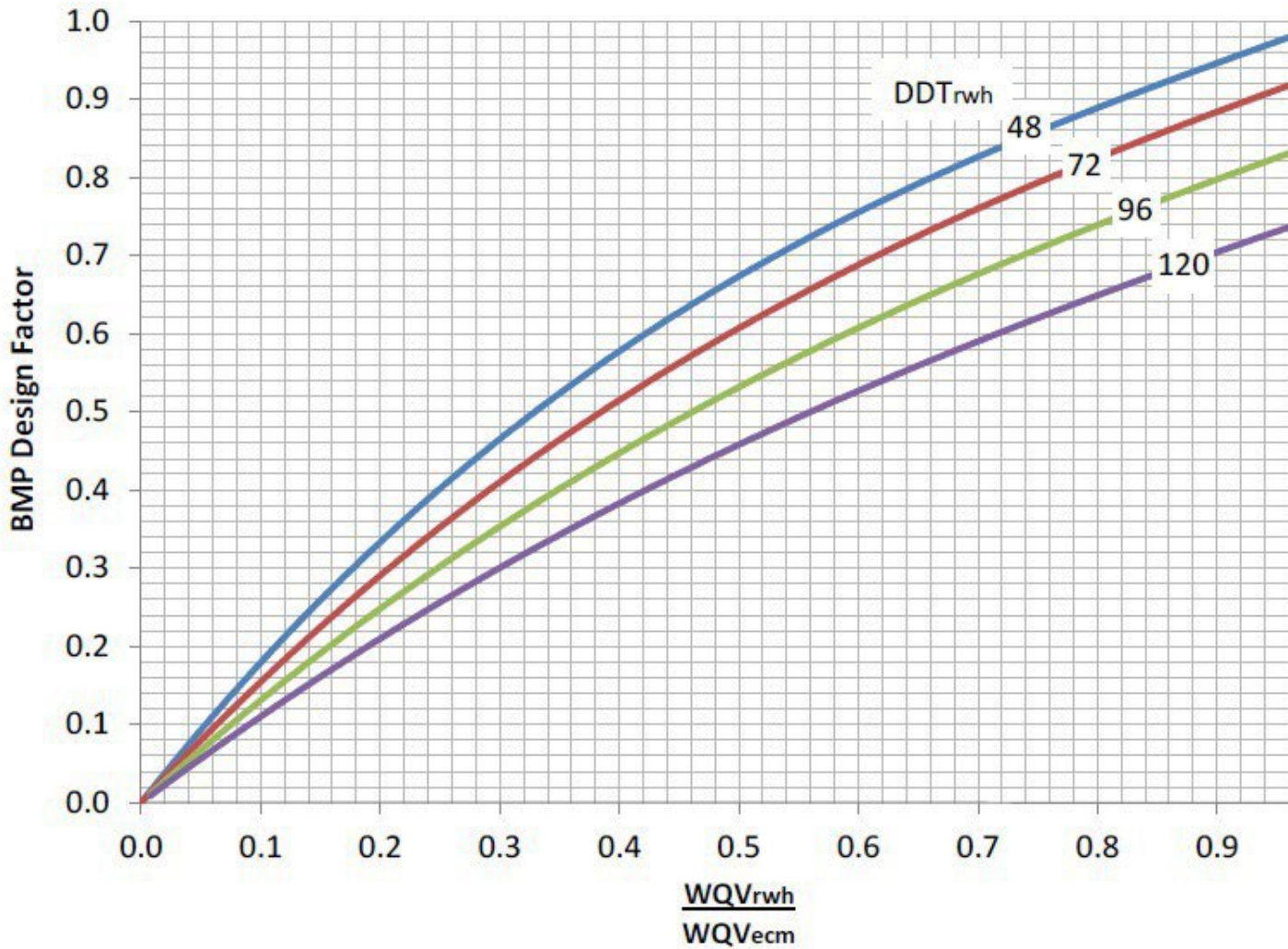

Figure 1.6.7.D-1. BMP Design Factor for **Type I** Rainwater Harvesting Systems.

The derivation of the drawdown time will vary with the type of system, as described below for specific design options. In all cases the drawdown is calculated as:

$$DDT = WQV/Q_{rwh}$$

- DDT is the drawdown time, or time for full control to empty, including any lag time (hours)
- WQV is the water quality volume
- $Q_{rwh}$  is the rate of discharge from the rainwater harvesting system

**B. Water Quality Credit for Type II rainwater harvesting systems.**

For Type II RWH systems, the approach for determining BMPDF is based on the Net Annual Reuse Demand Intensity (NARDI). The NARDI is a ratio of the net annual demand to the available rainwater storage capacity and is calculated as:

$NARDI = (D_{npr} - S_{acc}) / V_{rwh}$  Where:

- $D_{npr}$  is the annual non-potable reuse demand in gallons,
- $S_{acc}$  is the annual air conditioning condensate supply in gallons, and
- $V_{rwh}$  is the volume of the rainwater harvesting system tank in gallons.

Values for  $D_{npr}$  and  $S_{acc}$  shall be determined using Austin Water’s Water Balance Calculator, which is available at Austin Water’s Onsite Water Reuse web page (<https://www.austintexas.gov/department/onsite-water-reuse-systems>). The BMPDF for Type IIA systems can be determined using Figure 1.6.7.D-2 or the equation below:

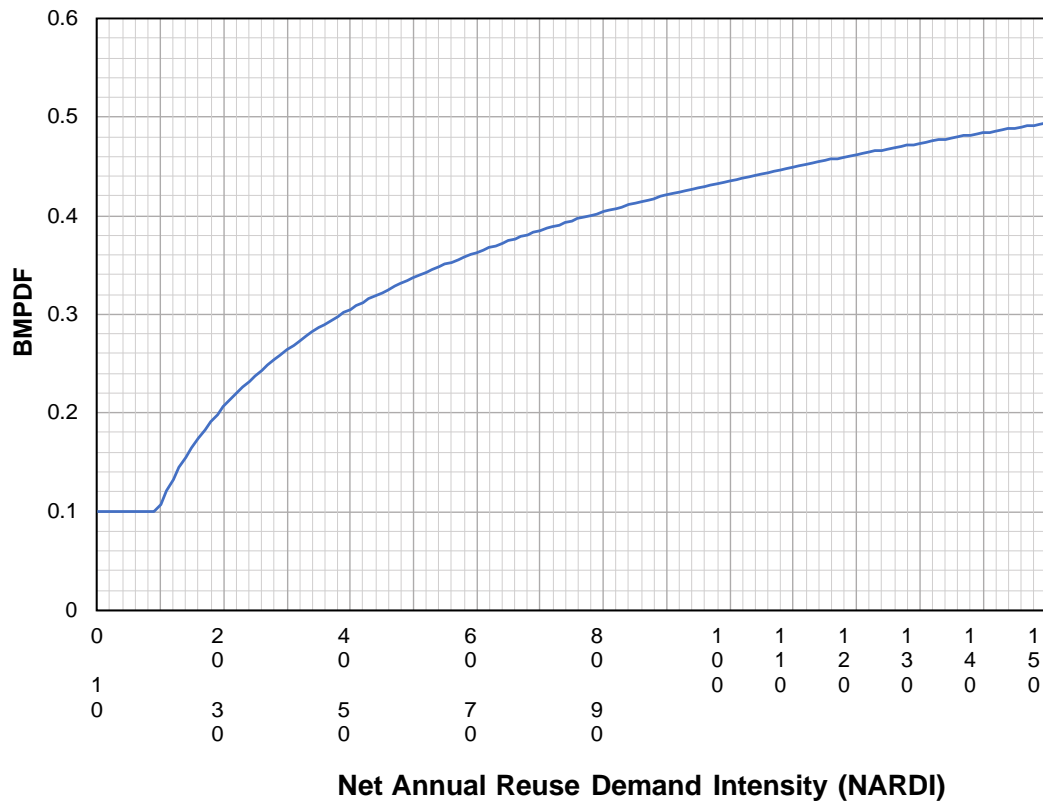

**Figure 1.6.7.D-2. BMP Design Factor for Type IIA Rainwater Harvesting Systems.**

For Type IIA systems, the BMPDF is calculated as:

$$\text{BMPDF} = \max(0.1, \min(0.5, 0.1429 \ln(\text{NARDI}) - 0.2221))$$

The equation above yields a BMPDF ranging between a minimum value of 0.1 and a maximum value of 0.5. The BMPDF is based on a Type IIA RWH. Systems designed to meet the minimum requirements of LDC §25-9-412 are considered Type IIA.

For Type IIB RWH systems, applicants must provide a site-specific engineering analysis. The site-specific engineering analysis shall demonstrate that average annual pollutant loads from the proposed developed site with the proposed Type IIB system do not exceed the average annual pollutant loads produced by the site under baseline conditions (as defined below). Applicants are encouraged to contact Watershed Protection Department and Austin Water Onsite Water Reuse staff prior to submitting plans proposing Type IIB systems. The site-specific engineering analysis shall meet the following requirements:

- SWMM software - The analysis shall be based on long-term continuous simulation calculations using the Environmental Protection Agency's Storm Water Management Model (SWMM) Version 5.2 or later and should follow COA's SWMM Guidance Manual which is available from the Watershed Protection Department. SWMM is a Windows-based desktop program. It is open-source public software and is free for use worldwide.
- Rainfall record – SWMM calculations shall incorporate a long-term continuous 13-year, 15-minute rainfall record (2006-2018) from the Lady Bird Lake gauge. The rainfall record is available from Austin Watershed Protection Department.
- Pollutant concentrations – Pollutant concentrations in runoff, SCM effluent, and SCM bypass shall be based on those listed in ECM Section 1.6.9. The pollutant loading analysis shall be based on total suspended solids, total phosphorus, and zinc. Pollutant concentrations in AC condensate shall be assumed to be zero. Pollutant concentrations in RWH system bypass shall be equal to those entering RWH systems.
- Baseline conditions scenario (see Figure 1.6.7.D-3) – SWMM shall be used to calculate average annual pollutant loads for the site for baseline conditions. For sites outside the Barton Springs Zone, the baseline scenario shall calculate annual pollutant load for the developed site including a sedimentation-filtration system sized with the standard half-inch plus WQV. For sites inside the Barton Springs Zone, the baseline scenario shall calculate pollutant loads for the existing site conditions in accordance with the Save Our Springs Ordinance.

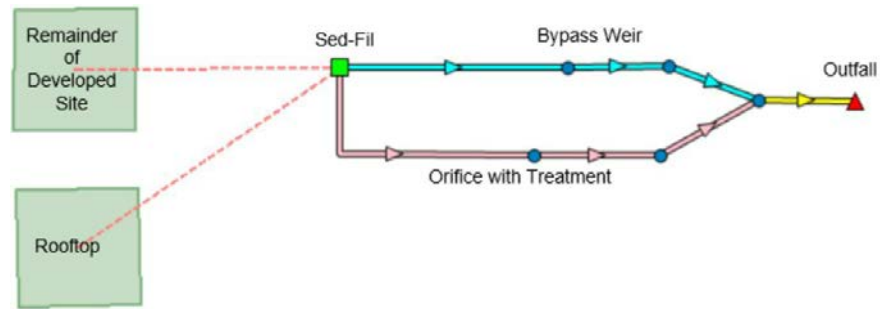

**Figure 1.6.7.D-3. Model Network for Sedimentation-Filtration Baseline Scenarios**

- Proposed conditions scenario (see Figure 1.6.7.D-4) – SWMM shall be used to calculate average annual pollutant loads for the site under proposed developed conditions. Proposed conditions shall include the Ordinance-mandated RWH system with the proposed RWH cistern. Overflow from the RWH system and runoff from the remainder of the developed site shall be routed to one or more stormwater control measure(s). The RWH system and other proposed SCMs shall be designed and sized to demonstrate that average annual pollutant loads for the site do not exceed the average annual pollutant loads for baseline conditions. The analysis shall account for reuse demands on a daily basis at rates and frequencies to match proposed conditions. For example, reuse rates for indoor commercial uses shall be applied five days per week if weekend demands are expected to be significantly less than weekday demands. Similarly, reuse rates for landscape irrigation shall be applied one or two days per week to match the expected irrigation frequency.

**Figure 1.6.7.D-4. Model Network for Beneficial Reuse Scenarios**

3. Design Options.

Because the required drawdown time is no more than five (5) days, these systems generally cannot be used to meet water conservation-oriented landscape irrigation needs (e.g., 5-day watering schedule). However, the portion of the system capacity that is recovered during the 5-day (maximum) drawdown period may be eligible for water quality credit. For example, water in the system may be pumped to a separate tank for subsequent beneficial reuse such as landscape irrigation during dry conditions. Or, a portion of the tank may be designated as water quality volume that empties within 5 days and the remaining portion of the tank is reserved for beneficial reuse. The amount of water harvested for beneficial reuse should be evaluated so that it may be usefully deployed over the service area to which it is directed. The annual capture and annual use (for irrigation, etc.) for the device should balance, and if they do not the annual use becomes the limiting capture quantity.

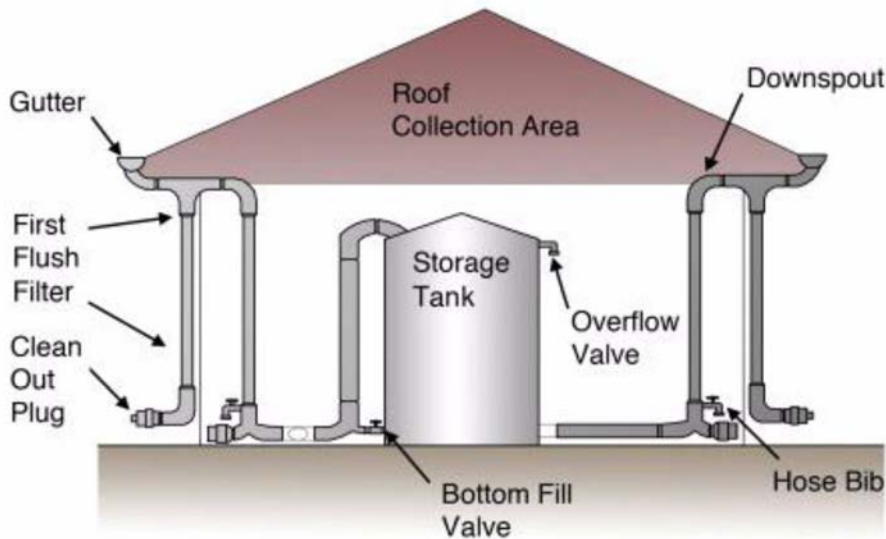

Figure 1.6.7.D-25. Typical configuration for a rainwater harvesting system.

Alternatively, and with approval from the Director, the system may be designed to empty or partially empty prior to the next forecasted rain event using an advanced real-time controller.

**Option A – Captured Runoff Gravity Drained to a Vegetated Area for Infiltration**

The average "treatment" rate of the rainwater harvesting system is:

$Q_{avg} = WQV/DDT$  Where:

- $Q_{avg}$  is the treatment rate
- WQV is the water quality volume
- DDT is the drawdown time, which is set to a maximum of 120 hours

It is reasonable to assume saturated conditions, and the infiltration rate of the vegetated area can be calculated as:  $Q_{veg} = k * i * A$

Where:

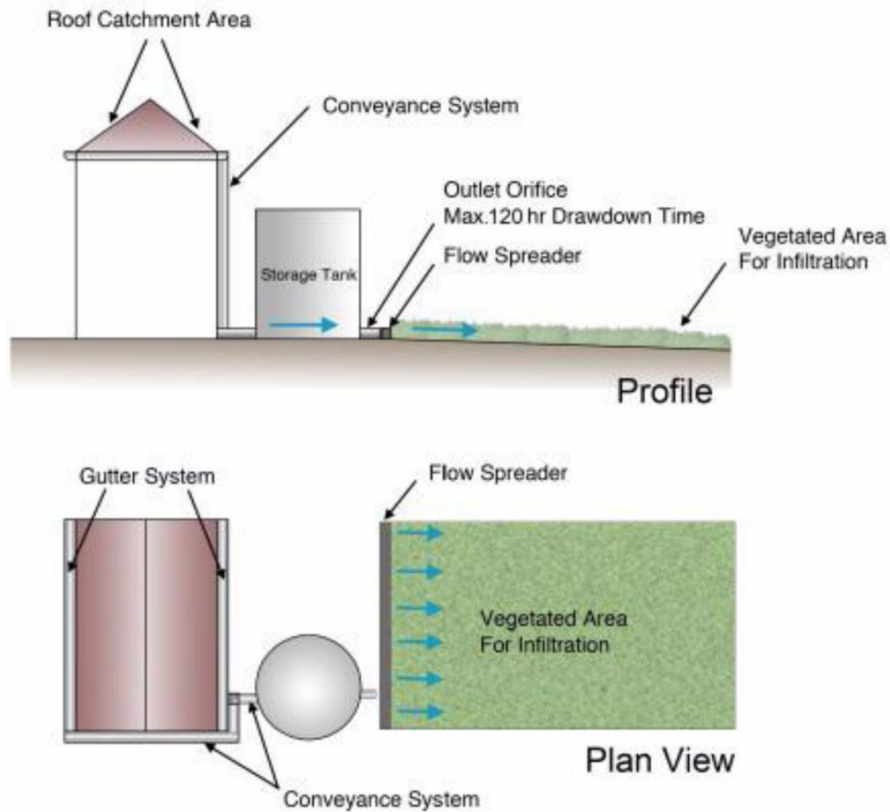

Figure 1.6.7.D-36. Design Option Type IA RWH System with captured runoff discharged to a vegetated area for infiltration.

As minimal ponding of water over the vegetated area is expected, the hydraulic gradient can be assumed equal to 1, thus:

$$Q_{veg} = k * A$$

To be conservative, design the vegetated area for the maximum flowrate discharged from the rainwater harvesting system. A reasonable assumption is to assume a value twice  $Q_{avg}$ , and to also assume a lag time (LT) between the time runoff ends and when the rainwater harvesting system begins discharging:

Setting the peak flow rate discharged from the rainwater harvesting system equal to the vegetated area infiltration rate, and solving for A:

$$A = (2 * WQV) / (k * (DDT - LT))$$

Where

A design infiltration rate (i.e., hydraulic conductivity) for the site must be established through desktop study and field sampling as described in Section 1.6.7.4. The lag time LT should be set to a minimum of 12 hours.

- The length (dimension in direction of flow) of the vegetative area should be at least 15 feet.
- The average slope of the vegetative area must be between 1% and 10%, with no portion exceeding 15%.

- The hydraulic loading rate should not exceed 0.05 cfs per ft. width for the maximum flowrate applied to the vegetated area (see below for procedure to calculate peak flowrate). Higher hydraulic loading rates are allowed but will reduce water quality credit. In this case, a maximum allowable rate of 0.15 cfs per ft. width is allowed.
- The soil depth should be a minimum of twelve (12) inches.
- The vegetated area should have dense vegetative cover (minimum 95% coverage as measured at the base of the vegetation). The use of native grasses is strongly recommended due to their resource efficiency and their ability to enhance soil infiltration. In the case of natural wooded areas where 95% vegetative cover is not present, a minimum of four inches of leaf litter or mulch must be in place.
- An irrigation plan is required. Type IA RWH systems are prohibited from having a potable water supply connection.

**Option B – Captured Runoff Used to Irrigate Vegetated Area**

**Design Guidance for Type IB RWH System - Captured Runoff Pumped to Vegetated Irrigation Area**

A typical design configuration in which captured runoff is **used pumped** to irrigate a vegetated area is shown in Figure 1.6.7.D-4 1.6.7.D-7 below. The water quality volume must be provided by the system designer, with the drawdown time set to a maximum of 120 hours. The system should be designed according to the retention/irrigation criteria in Section 1.6.7.A.

Rainwater systems are considered auxiliary water sources by the Austin Water Utility. When a rainwater harvesting system meets the definition of Auxiliary Water per the City of Austin - Utility Criteria Manual (UCM) then the design of this system must comply with the backflow protection requirements established in Section 2.3.4 of the UCM, Backflow Prevention Rules and Regulations Pertaining to Sites With Both City Potable Water and Auxiliary Water.

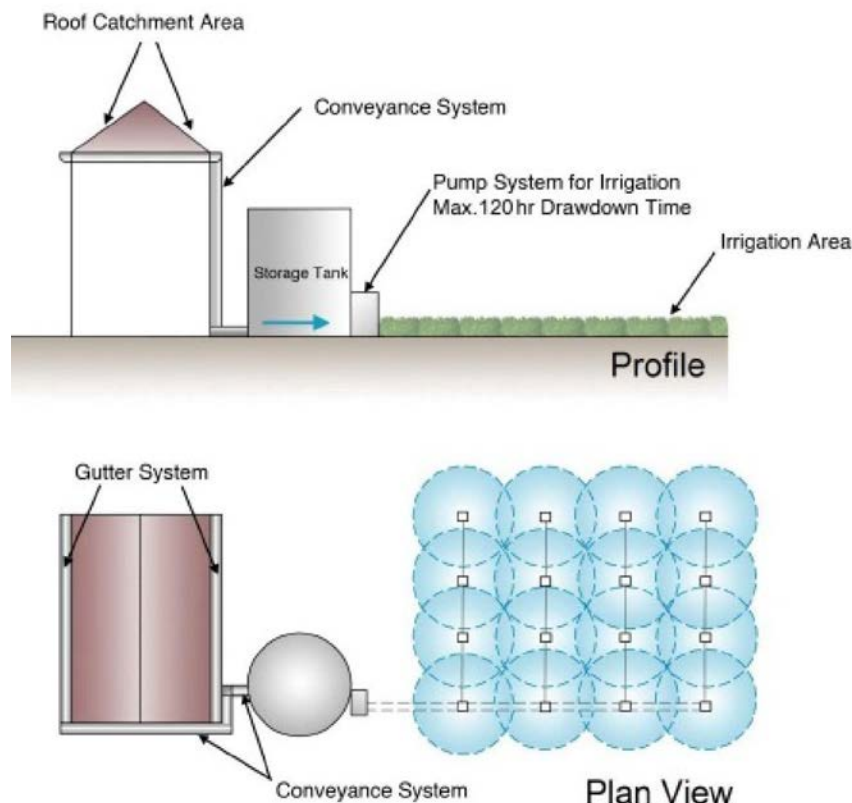

Figure 1.6.7.D-4 1.6.7.D-7. Design Option Type II B RWH system with captured runoff used to irrigate a vegetated area.

### Design Guidance for Type II Rainwater Harvesting Systems

Type II RWH systems (both A and B) must be designed in accordance with requirements set forth in Chapter 15-13 – Regulation of Onsite Water Reuse Systems of the City of Austin Code of Ordinances. Some developments may be required to install Type II systems per LDC §25-9-412 (Onsite Water Reuse System Requirement). In addition, Type II RWH systems are subject to in Chapters 15-1 (Cross Connection Regulations) and 25-12 (Technical Codes).

A 5 acre commercial development with 50% impervious cover (2.5 impervious acres) is proposing a rainwater harvesting system that would capture runoff from 1 acre of rooftop and drain it by gravity to a vegetated area (Option A). The development is located outside of the Barton Springs Zone. The system would have a water quality volume of 25,000 gallons, which would be emptied in 96 hours by discharging to a vegetated area that is 260' wide by 90' long. The design hydraulic conductivity for the site was established to be 0.06 in/hour, or 0.005 ft/hour. Evaluate this design and determine the water quality credit it may be eligible for.

The water quality credit will typically be applied as either a reduction in the water quality volume of a structural control or a reduction in the payment instead of structural controls.

As the alternative control is for 1 acres of impervious cover, and the site has a total of 2.5 impervious acres, the IAF value is 0.40 (=1/2.5).

- The BMPDF factor is a function of two components, the rainwater harvesting system and the vegetated area. The BMPDF value for the rainwater harvesting system is based on the water quality volume and drawdown time, subject to the requirement that the vegetated area must be large enough to infiltrate the captured volume.

To determine the BMPDF value, first convert the water quality volume from gallons to inches:

$$WQV_{rwh} = (25,000 \text{ gallons} * 1 \text{ ft}^3 / 7.481 \text{ gal}) = 3,342 \text{ ft}^3 = 0.92\text{-inch}$$

The BMPDF value is a function of the following factors:

$$WQV_{rwh} / WQV_{ecm} \text{ and } DDT_{rwh}$$

The rainwater harvesting system will be capturing runoff from a rooftop that is 100% impervious cover. The water quality capture depth for 100% impervious cover is 1.30-inch for projects located outside of the Barton Springs Zone. Therefore, the factors to determine BMPDF are:

$$WQV_{rwh} / WQV_{ecm} = 0.92 / 1.3 = 0.71, \text{ and } DDT_{rwh} = 96 \text{ hours.}$$

Inserting these values into Figure 1.6.7.D-1, gives: BMPDF = 0.68.

Before this credit can be applied first determine if the vegetated area is sufficient to infiltrate the water quality volume in 96 hours.

*Is it large enough?*

Minimum size  $A = (2 * WQV)/(k * (DDT - LT)) = (2 * 3,342)/(0.005 * (96-12)) = 15,914 \text{ ft}^2$ .

Size provided =  $260' * 90' = 23,400 \text{ ft}^2$  - this is large enough

*Is the length of the vegetated area at least 15 feet?*

Yes as the proposed length is 90 feet.

*Does it meet the 0.05 cfs/ft. width hydraulic loading rate for the discharge from the rainwater harvesting system?*

To estimate peak flowrate and hydraulic loading rate:

$Q_p = (2 * WQV)/(DDT - LT) = (2 * 3,342)/(96 - 12) = 80 \text{ cfh} = 0.022 \text{ cfs}$

$HLR = Q/W = 0.022/260 = 0.00008 \text{ cfs/ft width}$  - Okay as  $< 0.05$

All other slope, soil depth, vegetative cover, etc. criteria is also met, thus the vegetated area is acceptable and:

The total water quality credit for the proposed system is:  $WQC = IAF * BMPDF = 0.4 * 0.68 = 0.272$

5. **References:**

1. The Texas Manual on Rainwater Harvesting, 3rd edition 2005
2. City of Tucson Water Harvesting Guidance Manual, October 2005
3. City of Austin Energy, Green Building Program, 1995

*Note: the following table is only applicable to Type I rainwater harvesting systems. It is not applicable for determination of Water Quality Credit within the Barton Springs Zone, where different water quality criteria apply.*

**Appendix R-7A  
Rainwater Harvesting System Calculations  
for Development Permits**

**DRAINAGE DATA:**

Drainage Area to Control (DA) \_\_\_\_\_ Ac.  
 Drainage Area Impervious Cover \_\_\_\_\_ %  
 Capture Depth (CD) \_\_\_\_\_ Inches

**WATER QUALITY CONTROL CALCULATIONS:**

	<u>Required</u>		<u>Provided</u>
Water Quality Volume (WQV = CD*DA*3630)	_____	cf	_____ cf
Convert to Gallons			_____ Gallons

**OPTION A - CAPTURED RUNOFF GRAVITY DRAINED TO A VEGETATED AREA FOR INFILTRATION:**

Drawdown Time (DDT) \_\_\_\_\_ h  
 \_\_\_\_\_ o  
 \_\_\_\_\_ u  
 \_\_\_\_\_ r  
 \_\_\_\_\_ s

Hydraulic Conductivity \_\_\_\_\_ i  
 \_\_\_\_\_ n  
 \_\_\_\_\_ /  
 \_\_\_\_\_ h  
 \_\_\_\_\_ o  
 \_\_\_\_\_ u  
 \_\_\_\_\_ r

Lag Time (LT) \_\_\_\_\_ m \_\_\_\_\_ hours  
 \_\_\_\_\_ i \_\_\_\_\_  
 \_\_\_\_\_ n \_\_\_\_\_  
 \_\_\_\_\_ r \_\_\_\_\_  
 \_\_\_\_\_ 1 \_\_\_\_\_  
 \_\_\_\_\_ 2 \_\_\_\_\_  
 \_\_\_\_\_ 0 \_\_\_\_\_

Infiltration Area required \_\_\_\_\_ s  
 \_\_\_\_\_ q  
 \_\_\_\_\_ f  
 \_\_\_\_\_ t

**OPTION B - CAPTURED RUNOFF USED TO IRRIGATE VEGETATED AREA:**

Soil Permeability \_\_\_\_\_ i  
 \_\_\_\_\_ n  
 \_\_\_\_\_ /  
 \_\_\_\_\_ h  
 \_\_\_\_\_ o  
 \_\_\_\_\_ u  
 \_\_\_\_\_ r  
 \_\_\_\_\_ s

Drawdown Time \_\_\_\_\_ Max 120.0 \_\_\_\_\_ hours

Irrigation Rate \_\_\_\_\_ in/hour  
 Irrigation Area \_\_\_\_\_ sq ft

Note: Soil Depth for Infiltration and Irrigated Areas should be a minimum 12 inches

**WATER QUALITY CREDIT**

Impervious Area Factor (IAF)	max 1.0	_____
BMP Design Factor (BMPDF)	max 1.0	_____
Water Quality Credit (WQC = IAF*BMPDF)	max 1.0	_____
Water Quality Volume Reduction (WQV*WQC)		_____ cf

**STAGE-AREA-STORAGE TABLE**

Cistern:		
Stage (ft)*	A	Storage (cf)
	r	
	e	
	a	
	(	
	s	
	f	
	)	

\*in one foot or less increments(to be filled out by applicant)

---

Note: the following table is only applicable for Type IIA rainwater harvesting systems which provide 1 inch of capture depth off of rooftops and are outside of the Barton Springs Zone. Crediting for systems within the Barton Springs zone and/or with custom capture depths must provide site specific engineer analysis in accordance with Section 1.6.7.D.2(ii) of the Environmental Criteria Manual.

**Appendix R-7 B**  
**Type IIA Rainwater Harvesting System**  
**Calculations**  
**for Development Permits**

**NET ANNUAL DEMAND**

Annual non-potable reuse demand (Dnpr)

Annual air conditioning condensate supply (Sacc)Net annual demand

**CISTERN SIZE**

Roof area draining to cistern

Capture depth

Active\* volume of rainwater harvesting tank

\*Actual volume of cistern may need to be greater to account for lost active volume due to outlet locations or actuation valve settings

**WATER QUALITY CREDIT**

Net Annual Reuse Demand Intensity (NARDI)

Impervious Area Factor (IAF)

	g
	a
	l
	l
	o
	n
	s
	g
	a
	l
	l
	o
	n
	s
	g
	a
	l
	l
	o
	n
	s
	g
	a
	l
	l
	o
	n
	s
	s
	f
	i
	n
	c
	h
	g
	a
	l
	l
	o
	n
	s

BMP Design Factor (BMPDF)

Water Quality Credit (WQC = IAF\*BMPDF)

Water Quality Volume without Credit (WQV)

Water Quality Volume Reduction (WQV\*WQC)

c  
f  
c  
f