

25-0875

ORDINANCE AMENDMENT

Sponsored by

THE HONORABLE TONI PRECKWINKLE,  
PRESIDENT OF THE COOK COUNTY BOARD OF COMMISSIONERS

PROPOSED ORDINANCE AMENDMENT

COOK COUNTY ELECTRICAL CODE

**BE IT ORDAINED**, by the Cook County Board of Commissioners, that the Cook County Electrical Code is hereby amended as follows:

**110.17 Servicing and Maintenance of Equipment.** Servicing and electrical preventive maintenance shall be performed by qualified persons trained in servicing and maintenance of equipment and shall comply with the following:

(1) The servicing and electrical preventive maintenance shall be performed in accordance with the original equipment manufacturer's instructions and information included in listing information, applicable industry standards, or as approved by the authority having jurisdiction.

(2) The servicing and electrical preventive maintenance shall be performed using identified replacement parts that are verified under applicable product standards. The replacement parts shall comply with at least one of the following:

- a. Be provided by the original equipment manufacturer
- b. Be designed by an engineer experienced in the design of replacement parts for the type of equipment being serviced or maintained
- c. Be approved by the authority having jurisdiction

Informational Note No.1: For equipment that is not listed or field labeled, or for which components are no longer available from the original equipment manufacturer, one way to determine suitability is to review the documentation that accompanies the replacement parts.

Informational Note No. 2 See NFPA 70B, Standard for Electrical Equipment Maintenance, for information related to preventive maintenance for electrical, electronic, and communication systems equipment.

**110.22 Identification of Disconnecting Means.**

**(A) General.** Each disconnecting means shall be legibly marked to indicate its purpose unless located and arranged so the purpose is evident. In other than one- or two- family dwellings, the marking shall include the identification of the circuit source that supplies the disconnecting means. The marking shall be of sufficient durability to withstand the environment involved.

**110.25 Lockable Disconnecting Means.** If a disconnecting means is required to be lockable open elsewhere in this Code, it shall be capable of being locked in the open

position. The provisions for locking shall remain in place with or without the lock installed.

*Exception: Locking provisions for a cord-and-plug connection shall not be required to remain in place without the lock installed.*

**110.26 Spaces About Electrical Equipment.** ~~Access and Working space, and access to and egress from working space.~~ shall be provided and maintained about all electrical equipment to permit ready and safe operation and maintenance of such equipment. Open equipment doors shall not impede access to and egress from the working space. Access or egress is impeded if one or more simultaneously opened equipment doors restrict working space access to be less than 610 mm (24 in.) wide and 2.0 m (6 ½ ft) high

**210.8 Ground-Fault Circuit-Interrupter Protection for Personnel.** Ground-fault circuit-interruption for personnel shall be provided as required in 210.8(A) through (C). The ground-fault circuit-interrupter shall be installed in a readily accessible location.

Informational Note: See 215.9 for ground-fault circuit-interrupter protection for personnel on feeders.

**(B) Other Than Dwelling Units.** All 125-volt, single-phase, 15- and 20-ampere receptacles installed in the locations specified in 210.8(B)(1) through (8) shall have ground-fault circuit-interrupter protection for personnel.

(1) Bathrooms

(2) Kitchens

~~(3) Rooftops~~ Areas with sinks and permanent provisions for food preparation, beverage preparation, or cooking

~~(4) Outdoors~~ Buffet serving areas with permanent provisions for food serving, beverage serving, or cooking

(5) Rooftops

(6) Outdoors

(7) Sinks where receptacles or cord-and-plug-connected fixed or stationary appliances are installed within 1.8m (6 ft) from top inside edge of the bowl of the sink

(8) Indoor damp or wet locations

(9) Locker rooms with associated showering facilities

~~(10) Garages, accessory buildings, service bays, and similar areas where electrical diagnostic equipment, electrical hand tools, or portable lighting equipment are to be used other than vehicle exhibition halls and showrooms~~

~~(11) Crawl spaces at or below grade level~~

~~(12) Unfinished areas of basements~~

~~(13) Aquariums, bait wells, and similar open aquatic vessels or containers, such as tanks or bowls, where the receptacles are installed within 1.8m (6 ft) from the top inside edge or rim or from the conductive support framing of the vessel or container~~

~~(14) Laundry areas~~

(15) Bathtubs and shower stalls where receptacles are installed within 1.8 m (6 ft) of the outside edge of the bathtub or shower stall

*Exception No. 1: Receptacles that are not readily accessible and are supplied by a branch circuit dedicated to electric snow-melting, deicing, or pipeline and vessel heating equipment shall be permitted to be installed in accordance with 426.28 or 427.22, as applicable.*

*Exception No. 2: Receptacles on rooftops shall not be required to be readily accessible other than from the rooftop.*

*Exception No. 3: Receptacles or cord-and-plug-connected fixed and stationary appliances installed within 1.8 m (6 ft) from the top inside edge of a bowl of a sink shall not be required to be GFCI protected in industrial establishments where the conditions of maintenance and supervision ensure that only qualified personnel are involved, an assured equipment grounding conductor program in accordance with 590.6 (B)(2) shall be permitted for only those receptacle outlets used to supply equipment that would create a greater hazard if power is interrupted or that has a design not compatible with GFCI protection.*

*Exception No. 4: Receptacles or cord-and-plug-connected fixed and stationary appliances installed within 1.8 m (6 ft) from the top inside edge of a bowl of a sink shall not be required to be GFCI protected in industrial laboratories where the receptacles are used to supply equipment if removal of power would introduce a greater hazard.*

*Exception No. 5: Receptacles located in patient bed locations of Category 2 (general care) or Category 1 (critical care) spaces of health care facilities shall be permitted to comply with 517.21.*

*Exception No. 6: Listed weight-supporting ceiling receptacles (WSCR) utilized in combination with compatible weight-supporting attachment fitting (WSAF) installed for the purpose of serving a ceiling luminaire or ceiling-suspended fan shall be permitted to omit GFCI protection. If a general-purpose convenience receptacle is integral to the ceiling luminaire or ceiling-suspended fan, GFCI protection shall be provided.*

**210.62 Show Windows.** At least one 125-volt, single -phase, 15-or-20-ampere-ratedreceptacle outlet shall be installed within 450 mm (18 in.) of the top of each show window. for each 3.7 linear m (12 linear ft) or major fraction thereof of show window area measured horizontally at its maximum width. No point along the top of the window shall be farther than 1.8 m (6 ft) from a receptacle outlet.

**210.63 ~~Heating, Air Conditioning, and Refrigeration Equipment Outlet. Equipment Requiring Servicing.~~** A 125-volt, single-phase, 15- or 20- ampere- rated receptacle outlet shall be installed at an accessible location ~~for the servicing of heating, air-conditioning, and refrigeration equipment. The receptacle shall be located on the same level and within 7.5 m (25 ft) of the equipment as specified in 210.63 (A) and (B).~~ heating, air conditioning, and refrigeration equipment. The receptacle outlet shall not be connected to the load side of the equipment disconnecting means.

**(A) Heating, Air Conditioning, and Refrigeration Equipment.** The required receptacle outlet shall be located on the same level as the heating, air-conditioning, and refrigeration equipment. The receptacle outlet shall not be connected to the load side of the equipment's branch-circuit disconnecting means.

*Exception: A receptacle outlet shall not be required at one- and two-family dwellings for the service of evaporative coolers.*

**(B) Other Electrical Equipment.** In other than one- and two- family dwellings, a receptacle outlet shall be located as specified in 210.63 (B)(1) and (B)(2).

**(1) Indoor Service Equipment.** The required receptacle outlet shall be located within the same room or area as the service equipment.

**(2) Indoor Equipment Requiring Dedicated Equipment Spaces.** Where equipment, other than service equipment, requires dedicated equipment space as specified in 110.26 (E), the required receptacle outlet shall be located within the same room or area as the electrical equipment and shall not be connected to the load side of the equipment's disconnecting means.

Informational Note: See 210.8 for ground-fault circuit- interrupter requirements.

### **230.46 Spliced Conductors.**

Service-entrance conductors shall only be spliced in accordance with 230.46 (1) through (6). ~~of this section: Power distribution blocks, pressure connectors and devices for splices and taps installed on service conductors shall be marked "suitable for use on the line side of the service equipment" or equivalent.~~

- (1) Clamped or bolted connections in metering equipment enclosures;
- (2) Where service-entrance conductors are tapped from a utility controlled and locked (to prevent unauthorized access) bussed tap box, to supply two to six disconnecting means grouped at a common location;
- (3) In an approved utility owned service splice box, where utility sized conductors are connected to conductors that supply customers service equipment and are sized to this chapter;
- (4) A connection shall be permitted where service conductors are extended from a service drop to an outside meter location and returned to connect to the service-entrance conductors of an existing installation;
- (5) Where the service-entrance conductors consist of busway, connections shall be permitted as required to assemble the various sections and fittings;
- (6) For existing service-entrance conductors, it shall be permissible to install listed underground splice kits for:
  - (a) Repair of existing conductors;
  - (b) Extension of conductors by special permission.

### **230.67 Surge Protection.**

**(A) Surge Protective Device.** All services supplying the following occupancies shall be provided with a surge-protective device (SPD):

- (1) Dwelling Units
- (2) Dormitory Units
- (3) Guest rooms and guest suites or hotels and motels
- (4) Areas of nursing home and limited-care facilities used exclusively as patient sleeping rooms

**(B) Location.** The (SPD) shall be an integral part of the service equipment or shall be located immediately adjacent thereto.

Exception: The (SPD) shall not be required to be located at the service equipment as required in 230.67 (B) if located at each next level distribution equipment downstream toward the load.

**(C) Type.** The (SPD) shall be a Type 1 or Type 2 SPD.

**(D) Replacement.** Where service equipment is replaced, all of the requirements of this section shall apply.

**(E) Ratings.** SPD's shall have a nominal discharge current rating ( $I_n$ ) of not less than 10kA.

**240.67 Arc Energy Reduction.** Where fuses rated 1200 amperes or higher are installed, [240.67\(A\)](#), (B), and (C) shall apply.

**(A) Documentation.** Documentation shall be available to those authorized to design, install, operate, or inspect the installation as to the location of the fuses.

Documentation shall also be provided to demonstrate that the method chosen to reduce clearing time is set to operate at a value below the available arcing current.

**(B) Method to Reduce Clearing Time.** A fuse shall have a clearing time of 0.07 seconds or less at the available arcing current, or one of the following means shall be provided and shall be set to operate at less than the available arcing current:

- (1) Differential relaying
- (2) Energy-reducing maintenance switching with local status indicator
- (3) Energy-reducing active arc-flash mitigation system
- (4) Current-limiting, electronically actuated fuses
- (5) An approved equivalent means

Informational Note No. 1: An energy-reducing maintenance switch allows a worker to set a disconnect switch to reduce the clearing time while the worker is working within an arc-flash boundary as defined in *NFPA 70E-2021, Standard for Electrical Safety in the Workplace*, and then to set the disconnect switch back to a normal setting after the potentially hazardous work is complete.

Informational Note No. 2: An energy-reducing active arc-flash mitigation system helps in reducing arcing duration in the electrical distribution system. No change in the disconnect switch or the settings of other devices is required during maintenance when a worker is working within an arc-flash boundary as defined in *NFPA 70E-2021, Standard for Electrical Safety in the Workplace*.

Informational Note No. 3: IEEE 1584-2018, *IEEE Guide for Performing Arc Flash Hazard Calculations*, provides guidance in determining arcing current.

**(C) Performance Testing.** The arc energy reduction protection system shall be performance tested by primary current injection testing or another approved method when first installed on site. This testing shall be conducted by a qualified person(s) in accordance with the manufacturer's instructions.

A written record of this testing shall be made and shall be available to the authority having jurisdiction.

Informational Note: Some energy reduction protection systems cannot be tested using a test process of primary current injection due to either the protection method being damaged such as with the use of fuse technology or because current is not the primary method of arc detection.

**240.87 Arc Energy Reduction.** Where the highest continuous current trip setting for which the actual overcurrent device installed in a circuit breaker is rated or can be adjusted is 1200 amperes or higher, 240.87(A), (B), and (C) shall apply.

**(A) Documentation.** Documentation shall be available to those authorized to design, install, operate, or inspect the installation as to the location of the circuit breaker(s). Documentation shall also be provided to demonstrate that the method chosen to reduce clearing time is set to operate at a value below the available arcing current.

**(B) Method to Reduce Clearing Time.** One of the following means shall be provided and shall be set to operate at less than the available arcing current:

- (1) Zone-selective interlocking
- (2) Differential relaying
- (3) Energy-reducing maintenance switching with local status indicator
- (4) Energy-reducing active arc flash mitigation system
- (5) An instantaneous trip setting. Temporary adjustment of the instantaneous trip setting to achieve arc energy reduction shall not be permitted.
- (6) An instantaneous override
- (7) An approved equivalent means

Informational Note No. 1: An energy-reducing maintenance switch allows a worker to set a circuit breaker trip unit to “no intentional delay” to reduce the clearing time while the worker is working within an arc-flash boundary as defined in *NFPA 70E-2021, Standard for Electrical Safety in the Workplace*, and then to set the trip unit back to a normal setting after the potentially hazardous work is complete.

Informational Note No. 2: An energy-reducing active arc-flash mitigation system helps in reducing arcing duration in the electrical distribution system. No change in the circuit breaker or the settings of other devices is required during maintenance when a worker is working within an arc-flash boundary as defined in *NFPA 70E-2021, Standard for Electrical Safety in the Workplace*.

Informational Note No. 3: An instantaneous trip is a function that causes a circuit breaker to trip with no intentional delay when currents exceed the instantaneous trip setting or current level. If arcing currents are above the instantaneous trip level, the circuit breaker will trip in the minimum possible time.

Informational Note No. 4: See IEEE 1584-2018, *IEEE Guide for Performing Arc Flash Hazard Calculations*, for guidance in determining arcing current.

**(C) Performance Testing.** The arc energy reduction protection system shall be performance tested by primary current injection testing or another approved method when first installed on site. This testing shall be conducted by a qualified person(s) in accordance with the manufacturer's instructions.

A written record of this testing shall be made and shall be available to the authority having jurisdiction.

Informational Note: Some energy reduction protection systems cannot be tested using a test process of primary current injection due to either the protection method being damaged such as with the use of fuse technology or because current is not the primary method of arc detection.

**300.25 Exit Enclosures (Stair Towers).** Where an exit enclosure is required to have a fire resistance rating, only electrical wiring methods serving equipment permitted by the authority having jurisdiction in the exit enclosure shall be installed within the exit enclosure.

Exception: Where egress lighting is required on outside exterior doorways from the exit enclosure, luminaires shall be permitted to be supplied from the inside of the exit enclosure.

Informational Note: See NFPA 101-2021, Life Safety Code, 7.1.3.2.1(10)(b), for more information

#### **406.12 Tamper-Resistant Receptacles for Dwelling Units.**

In all areas specified in 210.52, All nonlocking-type 125-volt, 15- and 20-ampere receptacles in the following locations shall be listed tamper-resistant receptacles.

(1) All dwelling units, boathouses, mobile homes and manufactured homes, including their attached and detached garages, accessory buildings, and common areas

(2) Guest rooms and guest suites of hotels, motels, and their common areas

(3) Child care facilities

(4) Preschools and education facilities

(5) Within clinics, medical and dental offices, and outpatient facilities, the following spaces:

a. Business offices accessible to the general public

b. Lobbies, and waiting spaces

c. Spaces of nursing homes and limited care facilities covered in 517.10(B)(2)

(6) Places of awaiting transportation, gymnasiums, skating rinks, fitness centers, and auditoriums

(7) Dormitory units

(8) Residential care/assisted living facilities, social and substance abuse rehabilitation facilities, and group homes

(9) Foster care facilities, nursing homes, and psychiatric hospitals

(10) Areas of agricultural buildings accessible to the general public and any common areas

Informational Note No. 1: See ANSI/NEMA WD 6-2016, *Wiring Devices — Dimensional Specifications*. This requirement would include receptacles identified as 5-15, 5-20, 6-15, and 6-20.

Informational Note No. 2: See NFPA 5000-2021, *Building Construction and Safety Code*, and the *International Building Code (IBC)-2021* for more information on occupancy classifications for the types of facilities covered by this requirement.

Informational Note No. 3: Areas of agricultural building are frequently converted to hospitality areas. These areas can include petting zoos, stables, and buildings used for recreation or educational purposes where receptacles are installed.

*Exception (1) through (4): Receptacles in the following locations shall not be required to be tamper-resistant:*

- (1) *Receptacles located more than 1.7 m (5<sup>1</sup>/<sub>2</sub> ft) above the floor.*
- (2) *Receptacles that are part of a luminaire or appliance.*
- (3) *A single receptacle or a duplex receptacle for two appliances located within dedicated space for each appliance that, in normal use, is not easily moved from one place to another and that is cord-and-plug connected in accordance with 400.7(A)(6), (A)(7), or (A)(8).*
- (4) *Nongrounding receptacles used for replacements as permitted in 406.4(D)(2)(a).*

~~**406.13 Tamper-Resistant Receptacles in Guest Rooms and Guest Suites.** All nonlocking type, 125-volt, 15- and 20-ampere receptacles located in guest rooms and guest suites shall be listed tamper-resistant receptacles.~~

~~**406.14 Tamper-Resistant Receptacles in Child Care Facilities.** In all child care facilities, all nonlocking type, 125-volt, 15- and 20-ampere receptacles shall be listed tamper-resistant receptacles.~~

**408.6 Short-Circuit Current Rating.** Switchboards, switchgear, and panelboards shall have a short-circuit current rating not less than the available fault current. In other than one- and two-family dwelling units, the available fault current and the date the calculation was performed shall be field marked on the enclosure at the point of supply. The marking shall be of sufficient durability to withstand the environment involved.

## **Article 410 Part XVI Special Provisions for Horticultural Lighting Equipment**

### **410.170 General.**

Luminaires complying with Parts, I, II, III, IV, V, VI, VII, IX, X, XI, and XII of this article shall be permitted to be used for horticultural lighting. Part XVI shall additionally apply to lighting equipment specifically identified for horticultural use.

Informational Note: Lighting equipment identified for horticultural use is designed to provide a spectral characteristic needed for the growth of plants and can also provide supplemental general illumination within the growing environment.

### **410.172 Listing.**

Lighting equipment identified for horticultural use shall be listed.

**410.174 Installation and Use.**

Lighting equipment identified for horticultural use shall be installed and used in accordance with the manufacturer's installation instructions and installation markings on the equipment as required by that listing.

**410.176 Locations Not Permitted.**

(A) General Lighting. Lighting equipment identified for horticultural use shall not be installed as lighting for general illumination unless such use is indicated in the manufacturer's instructions.

(B) Installed Location. Lighting equipment identified for horticultural use shall not be installed where it is likely to be subject to physical damage or where concealed.

**410.178 Flexible Cord.**

Flexible cord shall only be permitted when provided as part of listed lighting equipment identified for horticultural use for any of the following uses:

- (1) Connecting a horticultural lighting luminaire directly to a branch circuit outlet
- (2) Interconnecting horticultural lighting luminaires
- (3) Connecting a horticultural lighting luminaire to a remote power source

Informational Note: Remote power sources include LED drivers, fluorescent ballasts, or HID ballasts.

**410.180 Fittings and Connectors.**

Fittings and connectors attached to flexible cords shall be provided as part of a listed horticultural lighting equipment device or system and installed in accordance with the instructions provided as part of that listing.

**410.182 Equipment Grounding Conductor.**

Lighting equipment identified for horticultural use shall be connected to the equipment grounding conductor in accordance with Part V of this article.

**410.184 Ground-Fault Circuit-Interrupter (GFCI) Protection and Special Purpose Ground-Fault Circuit-Interrupter (SPGFCI) Protection.**

Lighting equipment identified for horticultural use and employing flexible cord(s) with one or more separable connector(s) or attachment plug(s) shall be supplied by lighting outlets protected by a listed GFCI.

Exception: Circuits exceeding 150 volts to ground shall be protected by a listed SPGFCI.

Informational Note: See UL 943C, Outline of Investigation for Special Purpose Ground-Fault Circuit-Interrupters, for information on special purpose ground-fault circuit interrupters.

**410.186 Support.**

Fittings identified for support of horticultural lighting equipment shall be used in accordance with the installation instructions provided and shall be securely fastened.

**422.5 GFCI Protection.**

(A) General. Appliances identified in 422.5(A)(1) through (A)(7) 150 volts or less to ground and 60 amperes or less, single- or 3-phase, shall be provided with Class A protection for personnel. Multiple Class A protective devices shall be permitted but shall not be required.

- (1) Automotive vacuum machines
- (2) Drinking water coolers and bottle fill stations
- (3) Cord-and-plug-connected high-pressure spray washing machines
- (4) Tire inflation machines
- (5) Vending machines
- (6) Sump pumps
- (7) Dishwashers

Informational Note: Section 210.8 specifies requirements for GFCI protection for the branch-circuit outlet where the covered location warrants such protection.

**(B) Type and Location.**

The GFCI shall be readily accessible, listed, and located in one or more of the following locations:

- (1) Within the branch-circuit overcurrent device
- (2) A device or outlet within the supply circuit
- (3) An integral part of the attachment plug
- (4) Within the supply cord not more than 300 mm (12 in.) from the attachment plug
- (5) Factory installed within the appliance

**440.9 Grounding and Bonding.** Where equipment is installed outdoors on a roof, an equipment grounding conductor of the wire type shall be installed in outdoor portions of metallic raceway systems that use compression-type fittings.

**450.9 Ventilation.** The ventilation shall be adequate to dispose of the transformer full-load losses without creating a temperature rise that is in excess of the transformer rating. Transformers with ventilating openings shall be installed so that the ventilating openings are not blocked by walls or other obstructions. The required clearances shall be clearly marked on the transformer. Transformer top surfaces that are horizontal and readily accessible shall be marked to prohibit storage.

Informational Note No. 1: See ANSI/IEEE C57.12.00- 1993, *General Requirements for Liquid-Immersed Distribution, Power, and Regulating Transformers*, and ANSI/IEEE C57.12.01-1989, *General Requirements for Dry-Type Distribution and Power Transformers*.

Informational Note No. 2: Additional losses may occur in some transformers where nonsinusoidal currents are present, resulting in increased heat in the transformer above its rating. See ANSI/IEEE C57.110-1993, *Recommended Practice for Establishing Transformer Capability When Supplying Nonsinusoidal Load Currents*, where transformers are utilized with nonlinear loads.

**480.5 DC Disconnect Methods.**

**(A) Disconnecting Means.** A disconnecting means shall be provided for all ungrounded conductors derived from a stationary battery system over 50 volts. A disconnecting

means shall be readily accessible and located within sight of the ~~battery~~ stationary standby system.

Informational Note: See 240.21(H) for information on the location of the overcurrent device for battery conductors.

**(B) Emergency Disconnect.** For one-family and two-family dwellings, a disconnecting means or its remote control for a stationary standby battery shall be located at a readily accessible location outside the building for emergency use. The disconnect shall be labeled as follows:

#### EMERGENCY DISCONNECT

**(C) Disconnection of Series Battery Circuits.** Battery circuits exceeding 240 volts dc nominal between conductors or to ground and subject to field servicing shall have provisions to disconnect the series-connected strings into segments not exceeding 240 volts dc nominal for maintenance by qualified persons. Non-load-break bolted or plug-in disconnects shall be permitted.

**(D) Remote Actuation.** Where a disconnecting means, located in accordance with 480.5(A), is provided with remote controls to activate the disconnecting means and the controls for the disconnecting means are not located within sight of the stationary standby battery, the disconnecting means shall be capable of being locked in the open position, in accordance with 110.25, and the location of the controls shall be field marked on the disconnecting means.

**(E) Busway.** Where a dc busway system is installed, the disconnecting means shall be permitted to be incorporated into the busway.

**(F) Notification.** The disconnecting means shall be legibly marked in the field. A label with the marking shall be placed in a conspicuous location near the battery if a disconnecting means is not provided. The marking shall be of sufficient durability to withstand the environment involved and shall include the following:

(1) Nominal battery voltage

(2) Available fault current derived from the stationary standby battery

Informational Note No. 1: Battery equipment suppliers can provide information about available fault current on specific battery models.

(3) An arc flash label in accordance with acceptable industry practice

Informational Note No. 2: See NFPA 70E-2021, *Standard for Electrical Safety in the Workplace*, for assistance in determining the severity of potential exposure, planning safe work practices, arc flash labeling, and selecting personal protective equipment.

(4) Date the calculation was performed

Exception: List items (2), (3), and (4) shall not apply to one- and two-family dwellings.

**(G) Identification.** Stationary standby batteries shall be indicated by 480.5(G)(1) and (G)(2).

**(1) Facilities with Utility Services and Stationary Batteries.** Plaques or directories shall be installed in accordance with 705.10.

Exception: This requirement does not apply where a disconnect in 480.7(A) is not required.

**(2) Facilities with Stand-Alone Systems.** A permanent plaque or directory shall be installed in accordance with 710.10.

**518.6 Illumination.** Illumination shall be provided for all working spaces about fixed service equipment, switchboards, switchgear, panelboards, or motor control centers installed outdoors that serve assembly occupancies. Control by automatic means only shall not be permitted. Additional lighting outlets shall not be required where the workspace is illuminated by an adjacent light source.

**600.6 Disconnects.** Each sign and outline lighting system, feeder circuit or branch circuit supplying a sign, outline lighting system, or skeleton tubing shall be controlled by an externally operable switch or circuit breaker that opens all ungrounded conductors and controls no other load. The switch or circuit breaker shall open all ungrounded conductors simultaneously on multi-wire branch circuits in accordance with 210.4(B). Signs and outline lighting systems located within fountains shall have the disconnect located in accordance with 680.12.

*Exception No. 1: A disconnecting means shall not be required for an exit directional sign located within a building. Exception No. 2: A disconnecting means shall not be required for cord-connected signs with an attachment plug.*

**(A) Location.**

**(1) Within Sight of the Sign.** The disconnecting means shall be within sight of the sign or outline lighting system that it controls. Where the disconnecting means is out of the line of sight from any section that is able to be energized, the disconnecting means shall be capable of being locked in the open position. The provision for locking or adding a lock to the disconnecting means must remain in place at the switch or circuit breaker whether the lock is installed or not. Portable means for adding a lock to the switch or circuit breaker shall not be permitted. The disconnecting means, if located remote from the sign, sign body, or pole, shall be mounted at an accessible location available to first responders and service personnel. The location of the disconnect shall be marked with a label at the sign location and marked as the disconnect for the sign or outline lighting system.

**600.33 LED Sign Illumination Systems, Secondary Wiring.** The wiring methods and materials shall be installed in accordance with the sign manufacturer's installation instructions using any applicable wiring methods from Chapter 3 and the requirements for Class 2 circuits contained in Part III of Article 725.

**(C) Protection Against Physical Damage.** Where subject to physical damage, the conductors shall be protected and installed in accordance with 300.4. All through-wall penetrations shall be protected by a listed bushing or raceway.

**625.23 Disconnecting Means.** For EVSE and WPTE electric vehicle supply equipment rated more than 60 amperes or more than 150 volts to ground, the disconnecting means shall be provided and installed in a readily accessible location. The disconnecting means shall be capable of being locked in the open position. The provision for locking or adding a lock to the disconnecting means shall be installed on or at the switch or circuit breaker used as the disconnecting means and shall remain in place with or without the lock installed. Portable means for adding a lock to the switch or circuit breaker shall not be permitted. If the disconnecting means is installed remote from the equipment, a plaque shall be installed on the equipment denoting the location of the disconnecting means.

**625.40 Electric Vehicle Branch Circuit.** Each outlet installed for the purpose of supplying EVSE greater than 16 amperes or 120 volts shall be supplied by an individual branch circuit.

*Exception: Branch circuits shall be permitted to feed multiple EVSEs as permitted by 625.42 (A) or (B).*

**625.41 Overcurrent Protection.** Overcurrent protection for feeders and branch circuits supplying EVSE and WPTE, including bidirectional EVSE and WPTE, shall be sized for continuous duty and shall have a current rating of not less than 125 percent of the maximum load of the equipment. Where noncontinuous loads are supplied from the same feeder, the overcurrent device shall have a current rating of not less than the sum of the noncontinuous loads plus 125 percent of the continuous loads.

**625.42 Rating.** The EVSE shall have sufficient rating to supply the load served. Electric vehicle charging loads shall be considered to be continuous loads for the purposes of this article. Service and feeder shall be sized in accordance with the product ratings, unless the overall rating of the installation can be limited through controls as permitted by 625.42(A) or (B).

**(A) Energy Management System (EMS).** Where an EMS in accordance with 750.30 provides load management of EVSE, the maximum equipment load on a service and feeder shall be the maximum load permitted by the EMS. The EMS shall be permitted to be integral to one piece of equipment or integral to a listed system consisting of more than one piece of equipment. When one or more pieces of equipment are provided with an integral load management control, the system shall be marked to indicate this control is provided.

**(B) EVSE with Adjustable Settings.** EVSE with restricted access to an ampere adjusting means complying with 750.30(C) shall be permitted. If adjustments have an impact on the rating label, those changes shall be in accordance with manufacturer's instructions, and the adjusted rating shall appear on the rating label with sufficient durability to withstand the environment involved. EVSE as referenced shall be permitted to have ampere ratings that are equal to the adjusted current setting.

**625.44 Equipment Connection.** EVSE and WPTE shall be connected to the premises wiring system in accordance with one of the methods in 625.44(A) through (C).

**(A) Portable Equipment.** Portable equipment shall be connected to the premises wiring system by one or more of the following methods:

(1) A nonlocking, 2-pole, 3-wire grounding-type receptacle outlet rated at 125 volts, single phase, 15 or 20 amperes

(2) A nonlocking, 2-pole, 3-wire grounding-type receptacle outlet rated at 250 volts, single phase, 15 or 20 amperes

(3) A nonlocking, 2-pole, 3-wire or 3-pole, 4-wire grounding-type receptacle outlet rated at 250 volts, single phase, 30 or 50 amperes, or 125/250 volts, single-phase, 30, 50, or 60 amperes

(4) A nonlocking, 2-pole, 3-wire grounding-type receptacle outlet rated at 60 volts dc maximum, 15 or 20 amperes

**(B) Fastened-in-Place Equipment.** Equipment that is fastened-in-place shall be connected to the premises wiring system by one of the following methods:

(1) A nonlocking, 2-pole, 3-wire grounding-type receptacle outlet rated 125 volts or 250 volts, single phase, up to 50 amperes

(2) A nonlocking, 3-pole, 4-wire grounding-type receptacle outlet rated 250 volts, three phase, up to 50 amperes

(3) A nonlocking, 3-pole, 4-wire grounding-type receptacle outlet rated 125/250 volts, single phase, 30, 50, or 60 amperes

(4) A nonlocking, 2-pole, 3-wire grounding-type receptacle outlet rated 60 volts dc maximum, 15 or 20 amperes

**(C) Fixed-in-Place Equipment.** All other EVSE and WPTE shall be permanently wired and fixed-in-place to the supporting surface.

**625.54 Ground-Fault Circuit-Interrupter Protection for Personnel.** All receptacles installed for the connection of electric vehicle charging shall have ground-fault circuit-interrupter protection for personnel.

## **ARTICLE 690 Solar Photovoltaic (PV) Systems**

### **Part I. General**

#### **690.1 Scope.**

This article applies to solar PV systems, other than those covered by Article 691, including the array circuit(s), inverter(s), and controller(s) for such systems. The systems covered by this article include those interactive with other electric power production sources or stand-alone, or both. These PV systems may have ac or dc output for utilization.

Informational Note No. 1: See Informational Note Figure 690.1.

Informational Note No. 2: Article 691 covers the installation of large-scale PV electric supply stations.

**Informational Note Figure 690.1 Illustration of PV System DC Circuits and PV System Components in a Typical PV Installation.**

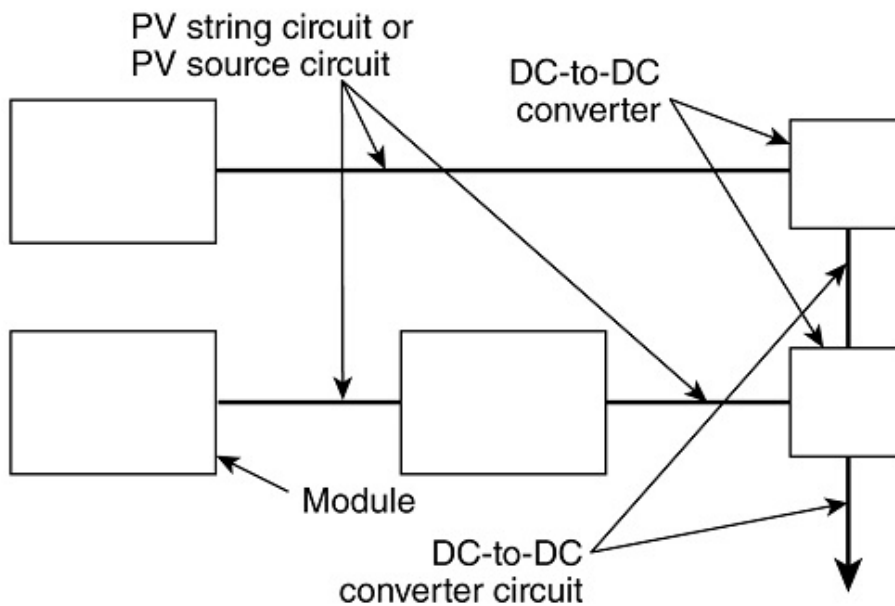
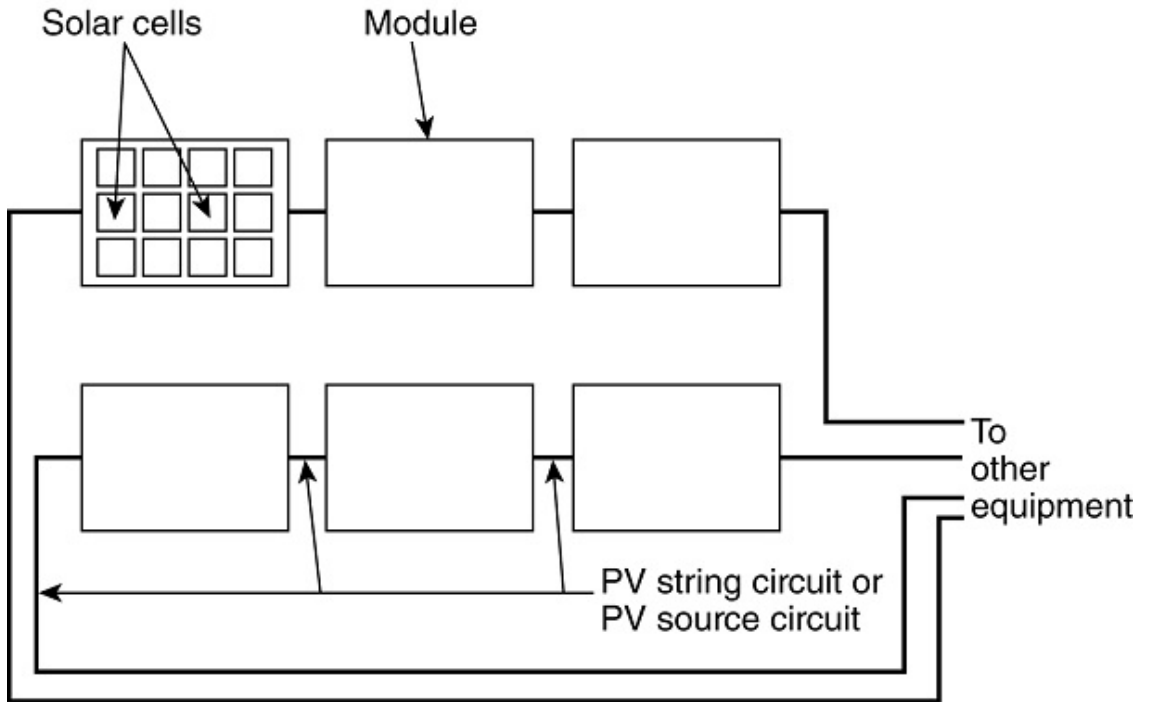
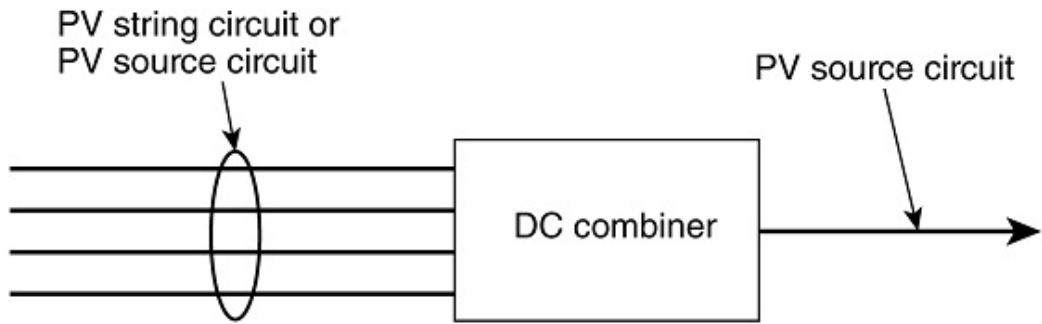

#### **690.4 General Requirements.**

##### **690.4(A) PV Systems.**

PV systems shall be permitted to supply a building or other structure in addition to any other electrical supply system(s).

##### **690.4(B) Equipment.**

Electronic power converters, motor generators, PV modules, ac modules and ac module systems, dc combiners, PV rapid shutdown equipment (PVRSE), PV hazard control equipment (PVHCE), PV hazard control systems (PVHCS), dc circuit controllers, and charge controllers intended for use in PV systems shall be listed or be evaluated for the application and have a field label applied.

##### **690.4(C) Qualified Personnel.**

The installation of equipment, associated wiring, and interconnections shall be performed only by qualified persons.

##### **690.4(D) Multiple PV Systems.**

Multiple PV systems shall be permitted to be installed in or on a single building or structure. Where the PV systems are remotely located from each other, a directory in accordance with 705.10 shall be provided at each PV system disconnecting means.

##### **690.4(E) Locations Not Permitted.**

PV system equipment and disconnecting means shall not be installed in bathrooms.

##### **690.4(F) Electronic Power Converters Mounted in Not Readily Accessible Locations.**

Electronic power converters and their associated devices shall be permitted to be mounted on roofs or other areas that are not readily accessible. Disconnecting means shall be installed in accordance with 690.15.

##### **690.4(G) PV Equipment Floating on Bodies of Water.**

PV equipment floating on or attached to structures floating on bodies of water shall be identified as being suitable for the purpose and shall utilize wiring methods that allow for any expected movement of the equipment.

Informational Note: PV equipment in these installations are often subject to increased levels of humidity, corrosion, and mechanical and structural stresses. Expected movement of floating PV arrays is often included in the structural design.

#### **690.6 Alternating-Current (ac) Modules and Systems.**

##### **690.6(A) Photovoltaic Source Circuits.**

The requirements of Article 690 pertaining to PV source circuits shall not apply to ac modules or ac module systems. The PV source circuit, conductors, and inverters shall be considered as internal components of an ac module or ac module system.

##### **690.6(B) Output Circuit.**

The output of an ac module or ac module system shall be considered an inverter output circuit.

## **Part II. Circuit Requirements**

### **690.7 Maximum Voltage.**

The maximum voltage shall be used to determine the voltage and voltage to ground of circuits in the application of this Code. Maximum voltage shall be used for conductors, cables, equipment, working space, and other applications where voltage limits and ratings are used. The maximum voltage of PV system dc circuits shall be the highest voltage between any two conductors of a circuit or any conductor and ground and shall comply with the following:

- (1) PV system dc circuits shall not exceed 1000 volts within or originating from arrays located on or attached to buildings and PV system dc circuits inside buildings.
- (2) PV system dc circuits shall not exceed 600 volts on or in one- and two-family dwellings.
- (3) PV system dc circuits exceeding 1000 volts shall comply with 690.31(G).

### **690.7(A) Photovoltaic Source Circuits.**

The maximum dc voltage for a PV source circuit shall be calculated in accordance with one of the following methods:

- (1) The sum of the PV module-rated open-circuit voltage of the series-connected modules in the PV string circuit corrected for the lowest expected ambient temperature using the open-circuit voltage temperature coefficients in accordance with the instructions included in the listing or labeling of the module
- (2) For crystalline and multicrystalline silicon modules, the sum of the PV module-rated open-circuit voltage of the series-connected modules in the PV string circuit corrected for the lowest expected ambient temperature using the correction factors provided in Table 690.7(A)
- (3) For PV systems with an inverter generating capacity of 100 kW or greater, a documented and stamped PV system design, using an industry standard method maximum voltage calculation provided by a licensed professional electrical engineer

Informational Note No. 1: One source for lowest-expected, ambient temperature design data for various locations the chapter titled “Extreme Annual Mean Minimum Design Dry Bulb Temperature” found in the ASHRAE Handbook — Fundamentals, 2017. These temperature data can be used to calculate maximum voltage.

Informational Note No. 2: See SAND 2004-3535, Photovoltaic Array Performance Model, for one industry standard method for calculating maximum voltage of a PV system.

### **Table 690.7(A) Voltage Correction Factors for Crystalline and Multicrystalline Silicon Modules**

**Correction Factors for Ambient Temperatures Below 25°C (77°F). (Multiply the rated open-circuit voltage by the appropriate correction factor shown below.)**

---

<u>Ambient Temperature (°C)</u>	<u>Factor</u>	<u>Ambient Temperature (°F)</u>
<u>24 to 20</u>	<u>1.02</u>	<u>76 to 68</u>
<u>19 to 15</u>	<u>1.04</u>	<u>67 to 59</u>

---

**Table 690.7(A) Voltage Correction Factors for Crystalline and Multicrystalline Silicon Modules**

**Correction Factors for Ambient Temperatures Below 25°C (77°F). (Multiply the rated open-circuit voltage by the appropriate correction factor shown below.)**

<u>Ambient Temperature (°C)</u>	<u>Factor</u>	<u>Ambient Temperature (°F)</u>
<u>14 to 10</u>	<u>1.06</u>	<u>58 to 50</u>
<u>9 to 5</u>	<u>1.08</u>	<u>49 to 41</u>
<u>4 to 0</u>	<u>1.10</u>	<u>40 to 32</u>
<u>-1 to -5</u>	<u>1.12</u>	<u>31 to 23</u>
<u>-6 to -10</u>	<u>1.14</u>	<u>22 to 14</u>
<u>-11 to -15</u>	<u>1.16</u>	<u>13 to 5</u>
<u>-16 to -20</u>	<u>1.18</u>	<u>4 to -4</u>
<u>-21 to -25</u>	<u>1.20</u>	<u>-5 to -13</u>
<u>-26 to -30</u>	<u>1.21</u>	<u>-14 to -22</u>
<u>-31 to -35</u>	<u>1.23</u>	<u>-23 to -31</u>
<u>-36 to -40</u>	<u>1.25</u>	<u>-32 to -40</u>

**690.7(B) DC-to-DC Converter Circuits.**

In PV dc-to-dc converter circuits, the maximum voltage shall be calculated in accordance with 690.7(B)(1) or (B)(2).

**690.7(B)(1) Single DC-to-DC Converter.**

For circuits connected to the output of a single dc-to-dc converter, the maximum voltage shall be determined in accordance with the instructions included in the listing or labeling of the dc-to-dc converter. If the instructions do not provide a method to determine the maximum voltage, the maximum voltage shall be the maximum rated voltage output of the dc-to-dc converter.

**690.7(B)(2) Two or More Series-Connected DC-to-DC Converters.**

For circuits connected to the output of two or more series-connected dc-to-dc converters, the maximum voltage shall be determined in accordance with the instructions included in the listing or labeling of the dc-to-dc converter. If the instructions do not provide a method to determine the maximum voltage, the maximum voltage shall be the sum of the maximum rated voltage output of the dc-to-dc converters in series.

### **690.7(C) Bipolar PV Source Circuits.**

For monopole subarrays in bipolar systems, the maximum voltage shall be the highest voltage between the monopole circuit conductors where one conductor of the monopole circuit is connected to the functionally grounded reference. To prevent overvoltage in the event of a ground fault or arc fault, the monopole circuits shall be isolated from ground.

### **690.7(D) Marking DC PV Circuits.**

A permanent readily visible label indicating the highest maximum dc voltage in a PV system, calculated in accordance with 690.7, shall be provided by the installer at one of the following locations:

- (1) DC PV system disconnecting means
- (2) PV system electronic power conversion equipment
- (3) Distribution equipment associated with the PV system

### **690.8 Circuit Sizing and Current.**

#### **690.8(A) Calculation of Maximum Circuit Current.**

The maximum current for the specific circuit shall be calculated in accordance with one of the methods in 690.8(A)(1) or (A)(2).

#### **690.8(A)(1) PV System Circuits.**

The maximum current shall be calculated in accordance with 690.8(A)(1)(a) through (A)(1)(c).

(a) Photovoltaic Source Circuit Currents The maximum current shall be as calculated in either of the following:

- (1) The maximum current shall be the sum of the short-circuit current ratings of the PV modules connected in parallel multiplied by 125 percent.
- (2) For PV systems with an inverter generating capacity of 100 kW or greater, a documented and stamped PV system design, using an industry standard method maximum current calculation provided by a licensed professional electrical engineer, shall be permitted. The calculated maximum current value shall be based on the highest 3-hour current average resulting from the simulated local irradiance on the PV array accounting for elevation and orientation. The current value used by this method shall not be less than 70 percent of the value calculated using 690.8(A)(1)(a)(1).

Informational Note: See SAND 2004-3535, *Photovoltaic Array Performance Model*, for one industry standard method for calculating maximum current of a PV system. This model is used by the System Advisor Model simulation program provided by the National Renewable Energy Laboratory.

(b) PV DC-to-DC Converter Circuit Current. The maximum current shall be the sum of parallel connected dc-to-dc converter continuous output current ratings.

(c) Inverter Output Circuit Current. The maximum current shall be the inverter continuous output current rating.

Informational Note: Modules that can produce electricity when exposed to light on multiple surfaces are labeled with applicable short-circuit currents. Additional guidance is provided in the instructions included with the listing.

#### **690.8(A)(2) Circuits Connected to the Input of Electronic Power Converters.**

Where a circuit is protected with an overcurrent device not exceeding the conductor ampacity, the maximum current shall be permitted to be the rated input current of the electronic power converter input to which it is connected.

**690.8(B) Conductor Ampacity.**

Circuit conductors shall have an ampacity not less than the larger of 690.8(B)(1) or (B)(2).

**690.8(B)(1) Without Adjustment and Correction Factors.**

The minimum conductor size with an ampacity not less than the maximum currents calculated in 690.8(A) multiplied by 125 percent.

Exception: Circuits containing an assembly, together with its overcurrent device(s), that is listed for continuous operation at 100 percent of its rating shall be permitted to be used at 100 percent of its rating.

**690.8(B)(2) With Adjustment and Correction Factors.**

The maximum currents calculated in 690.8(A) with adjustment and correction factors.

**690.8(C) Systems with Multiple Direct-Current Voltages.**

For a PV power source that has multiple output circuit voltages and employs a common-return conductor, the ampacity of the common-return conductor shall not be less than the sum of the ampere ratings of the overcurrent devices of the individual output circuits.

**690.8(D) Multiple PV String Circuits.**

Where an overcurrent device is used to protect more than one set of parallel-connected PV string circuits, the ampacity of each conductor protected by the device shall not be less than the sum of the following:

- (1) The rating of the overcurrent device
- (2) The sum of the maximum currents as calculated in 690.8(A)(1)(a) for the other parallel-connected PV string circuits protected by the overcurrent device

**690.9 Overcurrent Protection.**

**690.9(A) Circuits and Equipment.**

PV system dc circuit and inverter output conductors and equipment shall be protected against overcurrent. Circuits sized in accordance with 690.8(A)(2) are required to be protected against overcurrent with overcurrent protective devices. Each circuit shall be protected from overcurrent in accordance with 690.9(A)(1), (A)(2), or (A)(3).

**690.9(A)(1) Circuits Where Overcurrent Protection Not Required.**

Overcurrent protective devices shall not be required where both of the following conditions are met:

- (1) The conductors have sufficient ampacity for the maximum circuit current.
- (2) The currents from all sources do not exceed the maximum overcurrent protective device rating specified for the PV module or electronic power converter.

**690.9(A)(2) Circuits Where Overcurrent Protection is Required on One End.**

A circuit conductor connected at one end to a current-limited supply, where the conductor is rated for the maximum circuit current from that supply, and also connected to sources having an available maximum circuit current greater than the ampacity of the conductor, shall be protected from overcurrent at the point of connection to the higher current source.

Informational Note: Photovoltaic system dc circuits and electronic power converter outputs powered by these circuits are current-limited and in some cases do not need

overcurrent protection. Where these circuits are connected to higher current sources, such as parallel-connected PV system dc circuits, energy storage systems, or a utility service, the overcurrent device is often installed at the higher current source end of the circuit conductor.

**690.9(A)(3) Other Circuits.**

Circuits that do not comply with 690.9(A)(1) or (A)(2) shall be protected with one of the following methods:

(1) Conductors not greater than 3 m (10 ft) in length and not in buildings, protected from overcurrent on one end

(2) Conductors not greater than 3 m (10 ft) in length and in buildings, protected from overcurrent on one end and in a raceway or metal clad cable

(3) Conductors protected from overcurrent on both ends

(4) Conductors not installed on or in buildings are permitted to be protected from overcurrent on one end of the circuit where the circuit complies with all of the following conditions:

a. The conductors are installed in metal raceways or metal-clad cables, or installed in enclosed metal cable trays, or underground, or where directly entering pad-mounted enclosures.

b. The conductors for each circuit terminate on one end at a single circuit breaker or a single set of fuses that limit the current to the ampacity of the conductors.

c. The overcurrent device for the conductors is an integral part of a disconnecting means or shall be located within 3 m (10 ft) of conductor length of the disconnecting means.

d. The disconnecting means for the conductors is installed outside of a building, or at a readily accessible location nearest the point of entrance of the conductors inside of a building, including installations complying with 230.6.

**690.9(B) Device Ratings.**

Overcurrent devices used in PV source circuits shall be listed for use in PV systems. Electronic devices that are listed to prevent backfeed current in PV system dc circuits shall be permitted to prevent overcurrent of conductors on the PV array side of the device. Overcurrent devices, where required, shall be rated in accordance with one of the following and permitted to be rounded up to the next higher standard size in accordance with 240.4(B):

(1) Overcurrent devices shall be rated not less than 125 percent of the maximum currents calculated in 690.8(A).

(2) An assembly, together with its overcurrent device(s), that is listed for continuous operation at 100 percent of its rating shall be permitted to be used at 100 percent of its rating.

Informational Note: Some electronic devices prevent backfeed current, which in some cases is the only source of overcurrent in PV system dc circuits.

**690.9(C) PV System DC Circuits.**

A single overcurrent protective device, where required, shall be permitted to protect the PV modules, dc-to-dc converters, and conductors of each circuit. Where single overcurrent protection devices are used to protect circuits, all overcurrent devices shall be placed in the same polarity for all circuits within a PV system. The overcurrent devices shall be accessible but shall not be required to be readily accessible.

Informational Note: Due to improved ground-fault protection required in PV systems by 690.41(B), a single overcurrent protective device in either the positive or negative

conductors of a PV system in combination with this ground-fault protection provides adequate overcurrent protection.

#### **690.9(D) Transformers.**

Overcurrent protection for power transformers shall be installed in accordance with 705.30(F).

*Exception: A power transformer with a current rating on the side connected toward the interactive inverter output, not less than the rated continuous output current of the inverter, shall be permitted without overcurrent protection from the inverter.*

#### **690.11 Arc-Fault Circuit Protection (dc).**

Photovoltaic systems with PV system dc circuits operating at 80 volts dc or greater between any two conductors shall be protected by a listed PV arc-fault circuit interrupter or other system components listed to provide equivalent protection. The system shall detect and interrupt arcing faults resulting from a failure in the intended continuity of a conductor, connection, module, or other system component in the PV system dc circuits.

*Exception: PV system dc circuits that utilize metal-clad cables, are installed in metal raceways or enclosed metal cable trays, or are underground shall be permitted without arc-fault circuit protection if the installation complies with at least one of the following:*

- (1) The PV system dc circuits are not installed in or on buildings.*
- (2) The PV system dc circuits are located in or on detached structures whose sole purpose is to support or contain PV system equipment.*

#### **690.12 Rapid Shutdown of PV Systems on Buildings.**

PV system circuits installed on or in buildings shall include a rapid shutdown function to reduce shock hazard for firefighters in accordance with 690.12(A) through (D).

*Exception No. 1: Ground-mounted PV system circuits that enter buildings, of which the sole purpose is to house PV system equipment, shall not be required to comply with 690.12.*

*Exception No. 2: PV equipment and circuits installed on nonenclosed detached structures including but not limited to parking shade structures, carports, solar trellises, and similar structures shall not be required to comply with 690.12.*

Informational Note: Exceptions for rapid shutdown are intended to be consistent with building and fire codes that have limitations as to the types of buildings on which firefighters typically perform rooftop operations.

#### **690.12(A) Controlled Conductors.**

Requirements for controlled conductors shall apply to the following:

- (1) PV system dc circuits
- (2) Inverter output circuits originating from inverters located within the array boundary

Informational Note: The rapid shutdown function reduces the risk of electrical shock that dc circuits in a PV system could pose for firefighters. The ac output conductors from PV systems that include inverters will either be de-energized after shutdown initiation or will remain energized by other sources such as a utility service. To prevent PV arrays with attached inverters from having energized ac conductors within the PV array(s), those circuits are also specifically controlled after shutdown initiation.

Exception: PV system circuits originating within or from arrays not attached to buildings that terminate on the exterior of buildings and PV system circuits installed in accordance with 230.6 shall not be considered controlled conductors for the purposes of 690.12.

#### **690.12(B) Controlled Limits.**

The use of the term *array boundary* in this section is defined as 305 mm (1 ft) from the array in all directions. Controlled conductors outside the array boundary shall comply with 690.12(B)(1) and inside the array boundary shall comply with 690.12(B)(2). Equipment and systems shall be permitted to meet the requirements of both inside and outside the array as defined by the manufacturer's instructions included with the listing.

#### **690.12(B)(1) Outside the Array Boundary.**

Controlled conductors located outside the boundary or more than 1 m (3 ft) from the point of entry inside a building shall be limited to not more than 30 volts within 30 seconds of rapid shutdown initiation. Voltage shall be measured between any two conductors and between any conductor and ground.

#### **690.12(B)(2) Inside the Array Boundary.**

The PV system shall comply with one of the following:

(1) The PV system shall provide shock hazard control for firefighters through the use of a PVHCS installed in accordance with the instructions included with the listing or field labeling. Where a PVHCS requires initiation to transition to a controlled state, the rapid shutdown initiation device required in 690.12(C) shall perform this initiation.

Informational Note No. 1: A listed or field-labeled PVHCS is comprised of either an individual piece of equipment that fulfills the necessary functions or multiple pieces of equipment coordinated to perform the functions as described in the installation instructions to reduce the risk of electric shock hazard within a damaged PV array for firefighters. See UL 3741, *Photovoltaic Hazard Control*.

(2) The PV system shall provide shock hazard control for firefighters by limiting the highest voltage inside equipment or between any two conductors of a circuit or any conductor and ground inside array boundary to not more than 80 volts within 30 seconds of rapid shutdown initiation.

Informational Note No. 2: Common methods include the use of PV equipment with a limited maximum voltage of 80 volts as determined by 690.7, PVRSE, PVHCE, or any combination of these.

#### **690.12(C) Initiation Device.**

Where circuits identified in 690.12(A) are required to meet the requirements in 690.12(B), an initiation device(s) shall be provided and shall initiate the rapid shutdown function. The device's "off" position shall indicate that the rapid shutdown function has been initiated for all PV systems connected to that device. For one-and two-family dwellings, an initiation device(s), where required, shall be located at a readily accessible outdoor location.

For a single PV system, the rapid shutdown initiation shall occur by the operation of any single initiation device. Devices shall consist of at least one or more of the following:

(1) Service disconnecting means

(2) PV system disconnecting means

(3) Readily accessible switch that plainly indicates whether it is in the “off” or “on” position

Where multiple PV systems are installed with rapid shutdown functions on a single service, the initiation device(s) shall consist of not more than six switches or six sets of circuit breakers, or a combination of not more than six switches and sets of circuit breakers, mounted in a single enclosure, or in a group of separate enclosures. These initiation device(s) shall initiate the rapid shutdown of all PV systems with rapid shutdown functions on that service.

**690.12(D) Buildings with Rapid Shutdown.**

Buildings with PV systems shall have a permanent label located at each service equipment location to which the PV systems are connected or at an approved readily visible location and shall indicate the location of rapid shutdown initiation devices. The label shall include a simple diagram of a building with a roof and shall include the following words:

SOLAR PV SYSTEM IS EQUIPPED WITH RAPID SHUTDOWN.  
TURN RAPID SHUTDOWN SWITCH TO THE “OFF” POSITION TO SHUT DOWN  
PV SYSTEM AND REDUCE SHOCK HAZARD IN ARRAY.

The title “SOLAR PV SYSTEM IS EQUIPPED WITH RAPID SHUTDOWN” shall have these letters capitalized and having a minimum height of 9.5 mm (3/8 in.). All text shall be legible and contrast the background.

Informational Note: See Informational Note Figure 690.12(D).

**Informational Note Figure 690.12(D) Label for Roof-Mounted PV Systems with Rapid Shutdown.**

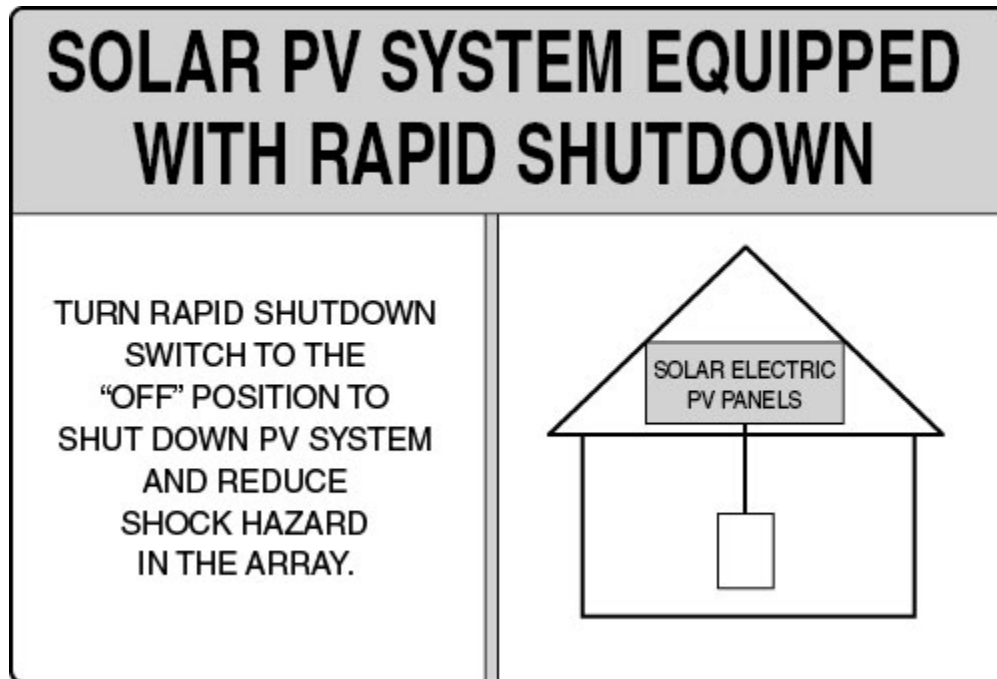

**690.12(D)(1) Buildings with More Than One Rapid Shutdown Type.**

For buildings that have PV systems with more than one rapid shutdown type or PV systems with no rapid shutdown, a detailed plan view diagram of the roof shall be provided showing each different PV system with a dotted line around areas that remain energized after rapid shutdown is initiated.

**690.12(D)(2) Rapid Shutdown Switch.**

A rapid shutdown switch shall have a label that includes the following wording located on or no more than 1 m (3 ft) from the switch:

**RAPID SHUTDOWN SWITCH FOR SOLAR PV SYSTEM**

The label shall be reflective, with all letters capitalized and having a minimum height of 9.5 mm (3/8 in.) in white on red background.

**Part III. Disconnecting Means**

**690.13 Photovoltaic System Disconnecting Means.**

Means shall be provided to disconnect the PV system from all wiring systems including power systems, energy storage systems, and utilization equipment and its associated premises wiring.

**690.13(A) Location.**

**690.13(A)(1) Readily Accessible.**

The PV system disconnecting means shall be installed at a readily accessible location.

**690.13(A)(2) Enclosure Doors and Covers.**

Where a disconnecting means for circuits operating above 30 volts is readily accessible to unqualified persons, an enclosure door or hinged cover that exposes energized parts when open shall have its door or cover locked or require a tool to be opened.

**690.13(B) Marking.**

Each PV system disconnecting means shall plainly indicate whether in the open (off) or closed (on) position and be permanently marked "PV SYSTEM DISCONNECT" or equivalent. Additional markings shall be permitted based upon the specific system configuration. For PV system disconnecting means where the line and load terminals may be energized in the open position, the device shall be marked with the following words or equivalent:

**WARNING**

**ELECTRIC SHOCK HAZARD TERMINALS ON THE LINE AND LOAD SIDES MAY BE ENERGIZED IN THE OPEN POSITION**

The warning sign(s) or label(s) shall comply with 110.21(B).

**690.13(C) Maximum Number of Disconnects.**

Each PV system disconnecting means shall consist of not more than six switches or six sets of circuit breakers, or a combination of not more than six switches and sets of circuit breakers, mounted in a single enclosure, or in a group of separate enclosures. A single PV system disconnecting means shall be permitted for the combined ac output of one or more inverters or ac modules.

Informational Note: This requirement does not limit the number of PV systems connected to a service as permitted in 690.4(D). This requirement allows up to six disconnecting means to disconnect a single PV system. For PV systems where all power is converted through interactive inverters, a dedicated circuit breaker, in 705.12(B)(1), is an example of a single PV system disconnecting means.

**690.13(D) Ratings.**

The PV system disconnecting means shall have ratings sufficient for the maximum circuit current, available fault current, and voltage that is available at the terminals of the PV system disconnect.

**690.13(E) Type of Disconnect.**

The PV system disconnecting means shall simultaneously disconnect the PV system conductors that are not solidly grounded from all conductors of other wiring systems. The PV system disconnecting means or its remote operating device or the enclosure providing access to the disconnecting means shall be capable of being locked in accordance with 110.25. The PV system disconnecting means shall be one of the following:

- (1) A manually operable switch or circuit breaker
- (2) A connector meeting the requirements of 690.33(D)(1) or (D)(3)
- (3) A pull-out switch with the required interrupting rating
- (4) A remote-controlled switch or circuit breaker that is operable locally and opens automatically when control power is interrupted
- (5) A device listed or approved for the intended application

Informational Note: Circuit breakers marked “line” and “load” may not be suitable for backfeed or reverse current.

**690.15 Disconnecting Means for Isolating Photovoltaic Equipment.**

Disconnecting means of the type required in 690.15(A) shall be provided to disconnect ac PV modules, fuses, dc-to-dc converters, inverters, and charge controllers from all conductors that are not solidly grounded.

**690.15(A) Type of Disconnecting Means.**

Where a disconnect is required to isolate equipment, the disconnecting means shall be one of the following:

- (1) An equipment disconnecting means in accordance with 690.15(C)
- (2) An isolating device as part of listed equipment where an interlock or similar means prevents the opening of the isolating device under load
- (3) For circuits with a maximum circuit current of 30 amperes or less, an isolating device in accordance with 690.15(B)

**690.15(B) Isolating Device.**

An isolating device shall not be required to have an interrupting rating. Where an isolating device is not rated for interrupting the circuit current, it shall be marked “Do Not Disconnect Under Load” or “Not for Current Interrupting.” An isolating device shall not be required to simultaneously disconnect all current-carrying conductors of a circuit. The isolating device shall be one of the following:

- (1) A mating connector meeting the requirements of 690.33 and listed and identified for use with specific equipment
- (2) A finger-safe fuse holder
- (3) An isolating device that requires a tool to place the device in the open (off) position
- (4) An isolating device listed for the intended application

**690.15(C) Equipment Disconnecting Means.**

Equipment disconnecting means shall comply with the following:

- (1) Have ratings sufficient for the maximum circuit current, available fault current, and voltage that is available at the terminals.
- (2) Simultaneously disconnect all current-carrying conductors that are not solidly grounded to the circuit to which it is connected.
- (3) Be externally operable without exposing the operator to contact with energized parts and shall indicate whether in the open (off) or closed (on) position. Where not within sight or not within 3 m (10 ft) of the equipment, the disconnecting means or its remote operating device or the enclosure providing access to the disconnecting means shall be capable of being locked in accordance with 110.25.
- (4) Be one of the types in 690.13(E)(1) through (E)(5).

Equipment disconnecting means, other than those complying with 690.33, shall be marked in accordance with the warning in 690.13(B) if the line and load terminals can be energized in the open position.

Informational Note: A common installation practice is to terminate PV source-side dc conductors in the same manner that utility source-side ac conductors are generally connected on the line side of a disconnecting means. This practice is more likely to de-energize load-side terminals, blades, and fuses when the disconnect is in the open position and no energized sources are connected to the load side of the disconnect.

**690.15(D) Location and Control.**

Isolating devices or equipment disconnecting means shall comply with one or more of the following:

- (1) Located within the equipment
- (2) Located in sight from and readily accessible from the equipment for those to whom access is required
- (3) Lockable in accordance with 110.25
- (4) Provided with remote controls to activate the disconnecting means where the remote controls comply with one of the following:
  - a. The disconnecting means and their controls are located within the same equipment.
  - b. The disconnecting means is lockable in accordance with 110.25, and the location of the controls are marked on the disconnecting means.

**Part IV. Wiring Methods and Materials**

**690.31 Wiring Methods.**

**690.31(A) Wiring Systems.**

**690.31(A)(1) Serviceability.**

Where wiring devices with integral enclosures are used, sufficient length of cable shall be provided to facilitate replacement.

**690.31(A)(2) Where Readily Accessible.**

Where not guarded, PV system dc circuit conductors operating at voltages greater than 30 volts that are readily accessible to unqualified persons shall be installed in Type MC cable, in multiconductor jacketed cable, or in raceway.

**690.31(A)(3) Conductor Ampacity.**

The ampacity of 105°C (221°F) and 125°C (257°F) conductors shall be permitted to be determined by Table 690.31(A)(3)(1). For ambient temperatures greater than 30°C (86°F), the ampacities of these conductors shall be corrected in accordance with Table 690.31(A)(3)(2).

**Table 690.31(A)(3)(1) Ampacities of Insulated Conductors Rated Up To and Including 2000 Volts, 105°C Through 125°C (221°F Through 257°F), Not More Than Three Current-Carrying Conductors in Raceway, Cable, or Earth (Directly Buried), Based on Ambient Temperature of 30°C (86°F)**

<u>AWG</u>	<u>Types</u>	
	<u>PVC, CPE, XLPE 105°C</u>	<u>XLPE, EPDM 125°C</u>
<u>18</u>	<u>15</u>	<u>16</u>
<u>16</u>	<u>19</u>	<u>20</u>
<u>14</u>	<u>29</u>	<u>31</u>
<u>12</u>	<u>36</u>	<u>39</u>
<u>10</u>	<u>46</u>	<u>50</u>
<u>8</u>	<u>64</u>	<u>69</u>
<u>6</u>	<u>81</u>	<u>87</u>
<u>4</u>	<u>109</u>	<u>118</u>
<u>3</u>	<u>129</u>	<u>139</u>
<u>2</u>	<u>143</u>	<u>154</u>
<u>1</u>	<u>168</u>	<u>181</u>
<u>1/0</u>	<u>193</u>	<u>208</u>
<u>2/0</u>	<u>229</u>	<u>247</u>
<u>3/0</u>	<u>263</u>	<u>284</u>

**Table 690.31(A)(3)(1) Ampacities of Insulated Conductors Rated Up To and Including 2000 Volts, 105°C Through 125°C (221°F Through 257°F), Not More Than Three Current-Carrying Conductors in Raceway, Cable, or Earth (Directly Buried), Based on Ambient Temperature of 30°C (86°F)**

<b>AWG</b>	<b>Types</b>	
	<b><u>PVC, CPE, XLPE 105°C</u></b>	<b><u>XLPE, EPDM 125°C</u></b>
4/0	301	325

**Table 690.31(A)(3)(2) Correction Factors**

<b><u>Temperature Rating of Conductor</u></b>			
<b>Ambient Temp (°C)</b>	<b>105°C (221°F)</b>	<b>125°C (257°F)</b>	<b>Ambient Temp (°F)</b>
<b>30</b>	<b>1</b>	<b>1</b>	<b>86</b>
<b>31-35</b>	<b>0.97</b>	<b>0.97</b>	<b>87-95</b>
<b>36-40</b>	<b>0.93</b>	<b>0.95</b>	<b>96-104</b>
<b>41-45</b>	<b>0.89</b>	<b>0.92</b>	<b>105-113</b>
<b>46-50</b>	<b>0.86</b>	<b>0.89</b>	<b>114-122</b>
<b>51-55</b>	<b>0.82</b>	<b>0.86</b>	<b>123-131</b>
<b>56-60</b>	<b>0.77</b>	<b>0.83</b>	<b>132-140</b>
<b>61-65</b>	<b>0.73</b>	<b>0.79</b>	<b>141-149</b>
<b>66-70</b>	<b>0.68</b>	<b>0.76</b>	<b>150-158</b>
<b>71-75</b>	<b>0.63</b>	<b>0.73</b>	<b>159-167</b>
<b>76-80</b>	<b>0.58</b>	<b>0.69</b>	<b>168-176</b>
<b>81-85</b>	<b>0.52</b>	<b>0.65</b>	<b>177-185</b>
<b>86-90</b>	<b>0.45</b>	<b>0.61</b>	<b>186-194</b>
<b>91-95</b>	<b>0.37</b>	<b>0.56</b>	<b>195-203</b>
<b>96-100</b>	<b>0.26</b>	<b>0.51</b>	<b>204-212</b>
<b>101-105</b>	<b>-</b>	<b>0.46</b>	<b>213-221</b>
<b>106-110</b>	<b>-</b>	<b>0.4</b>	<b>222-230</b>
<b>111-115</b>	<b>-</b>	<b>0.32</b>	<b>231-239</b>
<b>116-120</b>	<b>-</b>	<b>0.23</b>	<b>240-248</b>

**690.31(A)(4) Special Equipment.**

In addition to wiring methods included elsewhere in this Code, other wiring systems specifically listed for use in PV systems shall be permitted.

Informational Note: See 110.14(C) for conductor temperature limitations due to termination provisions.

### **690.31(B) Identification and Grouping.**

#### **690.31(B)(1) Conductors of Different Systems.**

Where not otherwise allowed in an equipment's listing, PV system dc circuits shall not occupy the same equipment wiring enclosure, cable, or raceway as other non-PV systems or inverter output circuits unless separated from other circuits by a barrier or partition.

Exception: Where all conductors or cables have an insulation rating equal to at least the maximum circuit voltage applied to any conductor within the same wiring method, the following shall be permitted:

(1) Multiconductor jacketed cables for remote control, signaling, or power-limited circuits shall be permitted within the same wiring enclosure, cable, or raceway as PV system dc circuits where all circuits serve the PV system.

(2) Inverter output circuits shall be permitted to occupy the same junction box, pull box, or wireway with PV system dc circuits that are identified and grouped as required by 690.31(B)(2) and (B)(3).

(3) PV system dc circuits utilizing multiconductor jacketed cable or metal-clad cable assemblies or listed wiring harnesses identified for the application shall be permitted to occupy the same wiring method as inverter output circuits and other non-PV systems.

#### **690.31(B)(2) Identification.**

PV system dc circuit conductors shall be identified at all termination, connection, and splice points by color coding, marking tape, tagging, or other approved means in accordance with 690.31(B)(2)(a) and (B)(2)(b).

Exception: Where the identification of the conductors is evident by spacing or arrangement, further identification shall not be required.

(a) Conductors that rely on other than color coding for polarity identification shall be identified by an approved permanent marking means such as labeling, sleeving, or shrink-tubing that is suitable for the conductor size.

(b) The permanent marking means for nonsolidly grounded positive conductors shall include imprinted plus signs (+) or the word POSITIVE or POS durably marked on insulation of a color other than green, white, or gray. The permanent marking means for nonsolidly grounded negative conductors shall include imprinted negative signs (-) or the word NEGATIVE or NEG durably marked on insulation of a color other than green, white, gray, or red. Only solidly grounded PV system dc circuit conductors shall be marked in accordance with 200.6.

#### **690.31(B)(3) Grouping.**

Where ac and dc conductors of PV systems occupy the same junction box, pull box, or wireway, the ac and dc circuit conductors shall be grouped separately by cable ties or similar means at least once and at intervals not to exceed 1.8 m (6 ft).

Exception: The requirement for grouping shall not apply if the circuit enters from a cable or raceway unique to the circuit that makes the grouping obvious.

#### **690.31(C) Cables.**

Type PV wire or cable and Type distributed generation (DG) cable shall be listed.

Informational Note: See UL 4703, *Standard for Photovoltaic Wire*, for PV wire and UL 3003, *Distributed Generation Cables*, for DG cable. PV wire and cable and DG cable have a nonstandard outer diameter.

**690.31(C)(1) Single-Conductor Cable.**

Single-conductor cables shall comply with 690.31(C)(1)(a) through (C)(1)(c).

(a) Single-conductor cable in exposed outdoor locations in PV system dc circuits within the PV array shall be permitted to be one of the following:

(1) PV wire or cable

(2) Single-conductor cable marked sunlight resistant and Type USE-2 and Type RHW-2

(b) Exposed cables sized 8 AWG or smaller shall be supported and secured at intervals not to exceed 600 mm (24 in.) by cable ties, straps, hangers, or similar fittings listed and identified for securement and support in outdoor locations. PV wire or cable shall be permitted in all locations where RHW-2 is permitted.

Exception: PV systems meeting the requirements of 691.4 shall be permitted to have support and securement intervals as defined in the engineered design.

(c) Exposed cables sized larger than 8 AWG shall be supported and secured at intervals not to exceed 1400 mm (54 in.) by cable ties, straps, hangers, or similar fittings listed and identified for securement and support in outdoor locations.

**690.31(C)(2) Cable Tray.**

Single-conductor PV wire or cable of all sizes or distributed generation (DG) cable of all sizes, with or without a cable tray rating, shall be permitted in cable trays installed in outdoor locations, provided that the cables are supported at intervals not to exceed 300 mm (12 in.) and secured at intervals not to exceed 1400 mm (54 in.).

Where installed in uncovered cable trays, ampacity of single-conductor PV wire smaller than 1/0 AWG, the adjustment factors for 1/0 AWG single conductor cable in 392.80(A)(2) shall be permitted to be used.

Where single-conductor PV wire smaller than 1/0 AWG is installed in ladder ventilated trough cable trays, the following shall apply:

(1) All single conductors shall be installed in a single layer.

(2) Conductors that are bound together to comprise each circuit pair shall be permitted to be installed in other than a single layer.

(3) The sum of diameters of all single conductor cables shall not exceed the cable tray width.

**690.31(C)(3) Multiconductor Jacketed Cables.**

Where part of a listed PV assembly, multiconductor jacketed cables shall be installed in accordance with the included instructions. Where not part of a listed assembly, or where not otherwise covered in this *Code*, multiconductor jacketed cables, including DG cable, shall be installed in accordance with the product listing and shall be permitted in PV systems. These cables shall be installed in accordance with the following:

(1) In raceways, where on or in buildings other than rooftops

(2) Where not in raceways, in accordance with the following:

a. Marked sunlight resistant in exposed outdoor locations

b. Protected or guarded, where subject to physical damage

- c. Closely follow the surface of support structures
- d. Secured at intervals not exceeding 1.8 m (6 ft)
- e. Secured within 600 mm (24 in.) of mating connectors or entering enclosures
- f. Marked direct burial, where buried in the earth

**690.31(C)(4) Flexible Cords and Cables Connected to Tracking PV Arrays.**

Flexible cords and flexible cables, where connected to moving parts of tracking PV arrays, shall comply with Article 400 and shall be of a type identified as a hard service cord or portable power cable; they shall be suitable for extra-hard usage, listed for outdoor use, water resistant, and sunlight resistant. Allowable ampacities shall be in accordance with 400.5. Stranded copper PV wire shall be permitted to be connected to moving parts of tracking PV arrays in accordance with the minimum number of strands specified in Table 690.31(C)(4).

**Table 690.31(C)(4) Minimum PV Wire Strands**

<u>PV Wire AWG</u>	<u>Minimum Strands</u>
<u>18</u>	<u>17</u>
<u>16-10</u>	<u>19</u>
<u>8-4</u>	<u>49</u>
<u>2</u>	<u>130</u>
<u>1 AWG-1000 MCM</u>	<u>259</u>

**690.31(C)(5) Flexible, Fine-Stranded Cables.**

Flexible, fine-stranded cables shall be terminated only with terminals, lugs, devices, or connectors in accordance with 110.14.

**690.31(C)(6) Small-Conductor Cables.**

Single-conductor cables listed for outdoor use that are sunlight resistant and moisture resistant in sizes 16 AWG and 18 AWG shall be permitted for module interconnections where such cables meet the ampacity requirements of 400.5. Section 310.14 shall be used to determine the cable ampacity adjustment and correction factors.

**690.31(D) Direct-Current Circuits on or in Buildings.**

Wiring methods on or in buildings shall comply with the installation requirements in 690.31(D)(1) and (D)(2).

**690.31(D)(1) Metal Raceways and Enclosures.**

Where inside buildings, PV system dc circuits that exceed 30 volts or 8 amperes shall be contained in metal raceways, in Type MC metal-clad cable that complies with 250.118(A)(10)(b) or (A)(10)(c), or in metal enclosures.

Exception: PVHCS installed in accordance with 690.12(B)(2)(1) shall be permitted to be provided with or listed for use with nonmetallic enclosure(s), nonmetallic raceway(s), and cables other than Type MC metal-clad cable(s), at the point of penetration of the surface of the building.

#### **690.31(D)(2) Marking and Labeling.**

Unless located and arranged so the purpose is evident, the following wiring methods and enclosures that contain PV system dc circuit conductors shall be marked with the wording PHOTOVOLTAIC POWER SOURCE or SOLAR PV DC CIRCUIT by means of permanently affixed labels or other approved permanent marking:

- (1) Exposed raceways, cable trays, and other wiring methods
- (2) Covers or enclosures of pull boxes and junction boxes
- (3) Conduit bodies in which any of the available conduit openings are unused

The labels or markings shall be visible after installation. All letters shall be capitalized and shall be a minimum height of 9.5 mm ( $\frac{3}{8}$  in.) in white on a red background. Labels shall appear on every section of the wiring system that is separated by enclosures, walls, partitions, ceilings, or floors. Spacing between labels or markings, or between a label and a marking, shall not be more than 3 m (10 ft). Labels required by this section shall be suitable for the environment where they are installed.

#### **690.31(E) Bipolar Photovoltaic Systems.**

Where the sum, without consideration of polarity, of the voltages of the two monopole circuits exceeds the rating of the conductors and connected equipment, monopole circuits in a bipolar PV system shall be physically separated, and the electrical output circuits from each monopole circuit shall be installed in separate raceways until connected to the inverter. The disconnecting means and overcurrent protective devices for each monopole circuit output shall be in separate enclosures. All conductors from each separate monopole circuit shall be routed in the same raceway. Solidly grounded bipolar PV systems shall be clearly marked with a permanent, legible warning notice indicating that the disconnection of the grounded conductor(s) may result in overvoltage on the equipment.

*Exception: Listed switchgear rated for the maximum voltage between circuits and containing a physical barrier separating the disconnecting means for each monopole circuit shall be permitted to be used instead of disconnecting means in separate enclosures.*

#### **690.31(F) Wiring Methods and Mounting Systems.**

Roof-mounted PV array mounting systems shall be permitted to be held in place with an approved means other than those required by 110.13 and shall utilize wiring methods that allow any expected movement of the array.

Informational Note: Expected movement of unattached PV arrays is often included in structural calculations.

#### **690.31(G) Over 1000 Volts DC.**

Equipment and wiring methods containing PV system dc circuits with a maximum voltage greater than 1000 volts shall comply with the following:

- (1) Shall not be permitted on or in one- and two-family dwellings.
- (2) Shall not be permitted within buildings containing habitable rooms.
- (3) Where installed on the exterior of buildings shall be located less than 3 m (10 ft) above grade. Wiring methods containing PV system dc circuits connected to this equipment shall not be permitted to attach to the building greater than 10 m (33 ft) along the building surface from the equipment.

#### **690.32 Component Interconnections.**

Fittings and connectors that are intended to be concealed at the time of on-site assembly, where listed for such use, shall be permitted for on-site interconnection of modules or other array components. Such fittings and connectors shall be equal to the wiring method employed in insulation, temperature rise, and short-circuit current rating, and shall be capable of resisting the effects of the environment in which they are used.

**690.33 Mating Connectors.**

Mating connectors, other than connectors covered by 690.32, shall comply with 690.33(A) through (D).

**690.33(A) Configuration.**

The mating connectors shall be polarized and shall have a configuration that is noninterchangeable with receptacles in other electrical systems on the premises.

**690.33(B) Guarding.**

The mating connectors shall be constructed and installed so as to guard against inadvertent contact with live parts by persons.

**690.33(C) Type.**

The mating connectors shall be of the latching or locking type. Mating connectors that are readily accessible and that are used in circuits operating at over 30 volts dc or 15 volts ac shall require a tool for opening. Where mating connectors are not of the identical type and brand, they shall be listed and identified for intermatability, as described in the manufacturer's instructions.

**690.33(D) Interruption of Circuit.**

Mating connectors shall be one of the following:

- (1) Rated for interrupting current without hazard to the operator
- (2) A type that requires the use of a tool to open and marked "Do Not Disconnect Under Load" or "Not for Current Interrupting"
- (3) Supplied as part of listed equipment and used in accordance with instructions provided with the listed connected equipment

Informational Note: Some listed equipment, such as microinverters, are evaluated to make use of mating connectors as disconnect devices even though the mating connectors are marked as "Do Not Disconnect Under Load" or "Not for Current Interrupting."

**690.34 Access to Boxes.**

Junction, pull, and outlet boxes located behind modules or panels shall be so installed that the wiring contained in them can be rendered accessible directly or by displacement of a module(s) or panel(s) secured by removable fasteners and connected by a flexible wiring system.

**Part V. Grounding and Bonding**

**690.41 PV System DC Circuit Grounding and Protection.**

**690.41(A) PV System DC Circuit Grounding Configurations.**

One or more of the following system configurations shall be employed for PV system dc circuits:

- (1) 2-wire circuits with one functionally grounded conductor
- (2) Bipolar circuits according to 690.7(C) with a functional ground reference (center tap)
- (3) Circuits not isolated from the grounded inverter output circuit
- (4) Ungrounded circuits
- (5) Solidly grounded circuits as permitted in 690.41(B)
- (6) Circuits protected by equipment listed and identified for the use

**690.41(B) DC Ground-Fault Detector-Interrupter (GFDI) Protection.**

PV system dc circuits that exceed 30 volts or 8 amperes shall be provided with GFDI protection meeting the requirements of 690.41(B)(1) and (B)(2) to reduce fire hazards.

Solidly grounded PV source circuits with not more than two modules in parallel and not on or in buildings shall be permitted without GFDI protection.

Informational Note: Not all inverters, charge controllers, or dc-to-dc converters include dc GFDI protection. Equipment that does not have GFDI protection often includes the following statement in the manual: “Warning: This unit is not provided with a GFDI device.”

**690.41(B)(1) Ground-Fault Detection.**

The GFDI device or system shall detect ground fault(s) in the PV system dc circuits, including any functionally grounded conductors, and be listed for providing GFDI protection. For dc-to-dc converters not listed as providing GFDI protection, where required, listed GFDI protection equipment identified for the combination of the dc-to-dc converter and the GFDI device shall be installed to protect the circuit.

Informational Note: Some dc-to-dc converters without integral GFDI protection on their input (source) side can prevent other GFDI protection equipment from properly functioning on portions of PV system dc circuits.

**690.41(B)(2) Faulted Circuits.**

The faulted circuits shall be controlled by one of the following methods:

- (1) The current-carrying conductors of the faulted circuit shall be automatically disconnected.
- (2) The device providing GFDI protection fed by the faulted circuit shall automatically cease to supply power to output circuits and interrupt the faulted PV system dc circuits from the ground reference in a functionally grounded system.

**690.41(B)(3) Indication of Faults.**

The GFDI protection equipment shall provide indication of ground faults at a readily accessible location.

Informational Note: Examples of indication include, but are not limited to, the following: remote indicator light, display, monitor, signal to a monitored alarm system, or receipt of notification by web-based services.

**690.42 Point of PV System DC Circuit Grounding Connection.**

**690.42(A) Circuits with GFDI Protection.**

Circuits protected by GFDI equipment in accordance with 690.41(B) shall have any circuit-to-ground connection made by the GFDI equipment.

**690.42(B) Solidly Grounded Circuits.**

For solidly grounded PV system dc circuits, the grounding connection shall be made from any single point on the PV dc system to a point in the grounding electrode system in 690.47(A).

**690.43 Equipment Grounding and Bonding.**

Exposed non-current-carrying metal parts of PV module frames, electrical equipment, and conductor enclosures of PV systems shall be connected to an equipment grounding conductor in accordance with 250.134 or 250.136, regardless of voltage. Equipment grounding conductors and devices shall comply with 690.43(A) through (D).

**690.43(A) Photovoltaic Module Mounting Systems and Devices.**

Devices and systems used for mounting PV modules that are also used for bonding module frames shall be listed, labeled, and identified for bonding PV modules.

Informational Note: See UL 2703, *Standard for Mounting Systems, Mounting Devices, Clamping/Retention Devices, and Ground Lugs for Use with Flat-Plate Photovoltaic Modules and Panels for PV Module Clamps*, and UL 3703, *Standard for Solar Trackers*.

**690.43(B) Equipment Secured to Grounded Metal Supports.**

Devices listed, labeled, and identified for bonding and grounding the metal parts of PV systems shall be permitted to bond the equipment to grounded metal supports. Metallic support structures shall have identified bonding jumpers connected between separate metallic sections or shall be identified for equipment bonding and shall be connected to the equipment grounding conductor.

**690.43(C) Location.**

Equipment grounding conductors shall be permitted to be run separately from the PV system conductors within the PV array. Where PV system circuit conductors leave the vicinity of the PV array, equipment grounding conductors shall comply with 250.134.

**690.43(D) Bonding for Over 250 Volts.**

The bonding requirements contained in 250.97 shall apply only to solidly grounded PV system circuits operating over 250 volts to ground.

**690.45 Size of Equipment Grounding Conductors.**

Equipment grounding conductors for PV system circuits shall be sized in accordance with 250.122. Where no overcurrent protective device is used in the circuit, an assumed overcurrent device rated in accordance with 690.9(B) shall be used when applying Table 250.122.

Increases in equipment grounding conductor size to address voltage drop considerations shall not be required.

#### **690.47 Grounding Electrode System.**

##### **690.47(A) Buildings or Structures Supporting a PV System.**

A building or structure(s) supporting a PV system shall utilize a grounding electrode system installed in accordance with 690.47(B).

PV array equipment grounding conductors shall be connected to a grounding electrode system in accordance with Part VII of Article 250. This connection shall be in addition to any other equipment grounding conductor requirements in 690.43(C). The PV array equipment grounding conductors shall be sized in accordance with 690.45. For specific PV system grounding configurations permitted in 690.41(A), one of the following conditions shall apply:

(1) For PV systems that are not solidly grounded, the equipment grounding conductor for the output of the PV system, where connected to associated distribution equipment connected to a grounding electrode system, shall be permitted to be the only connection to ground for the system.

(2) For solidly grounded PV systems, as permitted in 690.41(A)(5), the grounded conductor shall be connected to a grounding electrode system by means of a grounding electrode conductor sized in accordance with 250.166.

Informational Note: Most PV systems are functionally grounded systems rather than solidly grounded systems as defined in this Code. For functionally grounded PV systems with an interactive inverter output, the ac equipment grounding conductor is connected to associated grounded ac distribution equipment. This connection is most often the connection to ground for ground-fault protection and equipment grounding of the PV array.

##### **690.47(B) Grounding Electrodes and Grounding Electrode Conductors.**

Additional grounding electrodes shall be permitted to be installed in accordance with 250.52 and 250.54. Grounding electrodes shall be permitted to be connected directly to the PV module frame(s) or support structure. A grounding electrode conductor shall be sized according to 250.66. A support structure for a ground-mounted PV array shall be permitted to be considered a grounding electrode if it meets the requirements of 250.52. PV arrays mounted to buildings shall be permitted to use the metal structural frame of the building if the requirements of 250.68(C)(2) are met.

#### **Part VI. Source Connections**

##### **690.56 Identification of Power Sources.**

Plaques or directories shall be installed in accordance with 705.10.

##### **690.59 Connection to Other Sources.**

PV systems connected to other sources shall be installed in accordance with Parts I and II of Article 705.

##### **690.72 Self-Regulated PV Charge Control.**

The PV source circuit shall be considered to comply with the requirements for charge control of a battery without the use of separate charge control equipment if the circuit meets both of the following:

(1) The PV source circuit is matched to the voltage rating and charge current requirements of the interconnected battery cells.

(2) The maximum charging current multiplied by 1 hour is less than 3 percent of the rated battery capacity expressed in ampere-hours or as recommended by the battery manufacturer.

## **ARTICLE 691 Large-Scale Photovoltaic (PV) Electric Supply Stations**

### **691.1 Scope.**

This article covers the installation of large-scale PV electric supply stations not under exclusive utility control.

Informational Note No. 1: Facilities covered by this article have specific design and safety features unique to large-scale PV facilities outlined in 691.4 and are operated for the sole purpose of providing electric supply to a system operated by a regulated utility for the transfer of electric energy.

Informational Note No. 2: See 90.2(B)(5) for additional information about utility-owned properties not covered under this Code. See ANSI/IEEE C2-2017, *National Electrical Safety Code*, for additional information on electric supply stations.

Informational Note No. 3: See Informational Note Figure 691.1.

**Informational Note Figure 691.1 Identification of Large-Scale PV Electric Supply Station Components.**

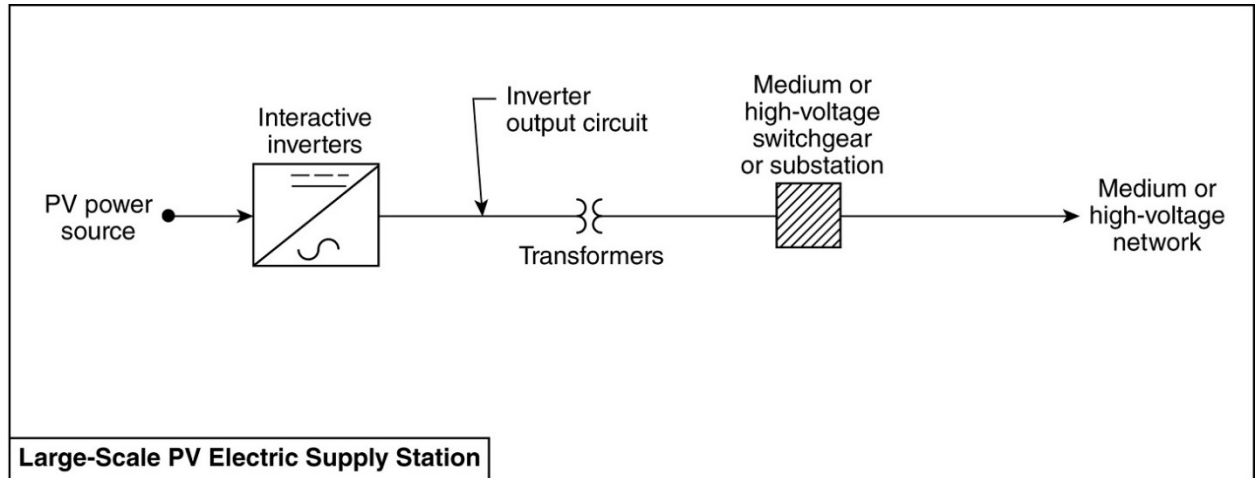

Notes:

- (1) The diagram is for informational purposes only and is not representative of all potential configurations.
- (2) Custom designs occur in each configuration, and some components are optional.

**691.4 Special Requirements for Large-Scale PV Electric Supply Stations.**

Large-scale PV electric supply stations shall be accessible only to authorized personnel and comply with the following:

- (1) Electrical circuits and equipment shall be maintained and operated only by qualified persons.

Informational Note No. 1: See NFPA 70E-2021, Standard for Electrical Safety in the Workplace, for electrical safety requirements.

- (2) Access to PV electric supply stations shall be restricted in accordance with 110.31. Field-applied hazard markings shall be applied in accordance with 110.21(B).

- (3) The connection between the PV electric supply station and the system operated by a utility for the transfer of electrical energy shall be through medium- or high-voltage switch gear, substation, switch yard, or similar methods whose sole purpose shall be to interconnect the two systems.

- (4) The electrical loads within the PV electric supply station shall only be used to power auxiliary equipment for the generation of the PV power.

- (5) Large-scale PV electric supply stations shall not be installed on buildings.

- (6) The station shall be monitored from a central command center.

- (7) The station shall have an inverter generating capacity of at least 5000 kW.

Informational Note No. 2: Some individual sites with capacities less than 5000 kW are operated as part of a group of facilities with a total generating capacity exceeding 5000 kW.

**691.5 Equipment.**

All electrical equipment shall be approved for installation by one of the following:

- (1) Listing and labeling
- (2) Be evaluated for the application and have a field label applied

(3) Where products complying with 691.5(1) or (2) are not available, by engineering review validating that the electrical equipment is evaluated and tested to relevant standards or industry practice

#### **691.6 Engineered Design.**

Documentation of the electrical portion of the engineered design of the electric supply station shall be stamped and provided upon request of the AHJ. Additional stamped independent engineering reports detailing compliance of the design with applicable electrical standards and industry practice shall be provided upon request of the AHJ. The independent engineer shall be a licensed professional electrical engineer retained by the system owner or installer. This documentation shall include details of conformance of the design with Article 690, and any alternative methods to Article 690, or other articles of this Code.

#### **691.7 Conformance of Construction to Engineered Design.**

Documentation that the construction of the electric supply station conforms to the electrical engineered design shall be provided upon request of the AHJ. Additional stamped independent engineering reports detailing the construction conforms with this Code, applicable standards and industry practice shall be provided upon request of the AHJ. The independent engineer shall be a licensed professional electrical engineer retained by the system owner or installer. This documentation, where requested, shall be available prior to commercial operation of the station.

#### **691.8 Direct Current Operating Voltage.**

For large-scale PV electric supply stations, calculations shall be included in the documentation required in 691.6.

#### **691.9 Disconnecting Means for Isolating Photovoltaic Equipment.**

Disconnecting means for equipment shall not be required within sight of equipment and shall be permitted to be located remotely from equipment. The engineered design required by 691.6 shall document disconnection procedures and means of isolating equipment.

Informational Note: See NFPA 70B-2019, *Recommended Practice for Electrical Equipment Maintenance*, for information on electrical system maintenance. See NFPA 70E-2021, *Standard for Electrical Safety in the Workplace*, for information on written procedures and conditions of maintenance, including lockout/tagout procedures.

Buildings whose sole purpose is to house and protect supply station equipment shall not be required to comply with 690.12. Written standard operating procedures shall be available at the site detailing necessary shutdown procedures in the event of an emergency.

#### **691.10 Fire Mitigation.**

PV systems that do not comply with the requirements of 690.11 shall include details of fire mitigation plans to address dc arc-faults in the documentation required in 691.6.

Informational Note: Fire mitigation plans are typically reviewed by the local fire agency and include topics such as access roads within the facility.

#### **691.11 Fence Bonding and Grounding.**

Fence grounding requirements and details shall be included in the documentation required in 691.6.

Informational Note: See 250.194 for fence bonding and grounding requirements enclosing substation portions of an electric supply station. Grounding requirements for other portions

of electric supply station fencing are assessed based on the presence of overhead conductors, proximity to generation and distribution equipment, and associated step and touch potential.

## **ARTICLE 692 Fuel Cell Systems**

### **Part I. General**

#### **692.1 Scope.**

This article applies to the installation of fuel cell systems.

Informational Note: Some fuel cell systems can be interactive with other electrical power production sources, are stand-alone, or both. Some fuel cell systems are connected to electric energy storage systems such as batteries. Fuel cell systems can have ac output(s), dc output(s), or both for utilization.

#### **692.4 Installation.**

##### **692.4(A) Fuel Cell System.**

A fuel cell system shall be permitted to supply a building or other structure in addition to any service(s) of another electricity supply system(s).

**692.4(B) Identification of Power Sources.**

Fuel cell systems shall be marked with a plaque or directory installed in accordance with 705.10.

**692.4(C) System Installation.**

The construction and operation of equipment, associated wiring, and interconnections shall be performed only by qualified persons.

Informational Note: See Article 100 for the definition of *qualified person*.

**692.6 Listing Requirement.**

The fuel cell system shall be approved for the application in accordance with one of the following:

- (1) Be listed for the application
- (2) Be evaluated for the application and have a field label applied

**Part II. Circuit Requirements**

**692.8 Circuit Sizing and Current.**

**692.8(A) Nameplate Rated Circuit Current.**

The nameplate(s) rated circuit current shall be the rated current indicated on the fuel cell nameplate(s).

**692.8(B) Conductor Ampacity and Overcurrent Device Ratings.**

The ampacity of the feeder circuit conductors from the fuel cell system(s) to the premises wiring system shall not be less than the greater of (1) nameplate(s) rated circuit current or (2) the rating of the fuel cell system(s) overcurrent protective device(s).

**692.8(C) Ampacity of Grounded or Neutral Conductor.**

If an interactive single-phase, 2-wire fuel cell output(s) is connected to the grounded or neutral conductor and a single ungrounded conductor of a 3-wire system or of a 3-phase, 4-wire, wye-connected system, the maximum unbalanced neutral load current plus the fuel cell system(s) output rating shall not exceed the ampacity of the grounded or neutral conductor.

**692.9 Overcurrent Protection.**

**692.9(A) Circuits and Equipment.**

If the fuel cell system is provided with overcurrent protection sufficient to protect the circuit conductors that supply the load, additional circuit overcurrent devices shall not be required. Equipment and conductors connected to more than one electrical source shall be protected.

**692.9(B) Accessibility.**

Overcurrent devices shall be readily accessible.

**Part III. Disconnecting Means**

**692.13 All Conductors.**

Means shall be provided to disconnect all current-carrying conductors of a fuel cell system power source from all other conductors in a building or other structure.

**692.17 Switch or Circuit Breaker.**

The disconnecting means for ungrounded conductors shall consist of readily accessible, manually operable switch(es) or circuit breaker(s).

Where all terminals of the disconnecting means may be energized in the open position, a warning sign shall be mounted on or adjacent to the disconnecting means. The sign shall be clearly legible and shall have the following words or equivalent:

**DANGER**

**ELECTRIC SHOCK HAZARD. DO NOT TOUCH TERMINALS. TERMINALS ON BOTH THE LINE AND LOAD SIDES MAY BE ENERGIZED IN THE OPEN POSITION.**

The danger sign(s) or label(s) shall comply with 110.21(B).

**Part IV. Wiring Methods**

**692.31 Wiring Systems.**

In addition to wiring methods included in Chapter 3 of this Code, wiring methods and fittings specifically listed and identified for use with fuel cell systems shall be permitted.

**Part V. Marking**

**692.50 Fuel Cell Power Sources.**

A marking specifying the fuel cell system, output voltage, output power rating, and continuous output current rating shall be provided at the disconnecting means for the fuel cell power source at an accessible location on the site.

**692.51 Fuel Shut-Off.**

The location of the manual fuel shut-off valve shall be marked at the location of the primary disconnecting means of the building or circuits supplied.

**692.52 Stored Energy.**

A fuel cell system that stores electrical energy shall require the following warning sign, or equivalent, at the location of the service disconnecting means of the premises:

**WARNING**

**FUEL CELL POWER SYSTEM CONTAINS ELECTRICAL ENERGY STORAGE DEVICES.**

The warning sign(s) or label(s) shall comply with 110.21(B).

**Part VI. Connection to Other Circuits**

**692.60 Connection to Other Systems.**

Fuel cell systems connected to other sources shall be installed in accordance with Parts I and II of Article 705.

**692.61 Transfer Switch.**

A transfer switch shall be required in non-grid-interactive systems that use utility grid backup. The transfer switch shall maintain isolation between the electrical production and distribution network and the fuel cell system. The transfer switch shall be permitted to be located externally or internally to the fuel cell system unit. Where the utility service conductors of the structure are connected to the transfer switch, the switch shall comply with Article 230, Part V.

## **ARTICLE 694 Wind Electric Systems**

### **Part I. General**

#### **694.1 Scope.**

This article applies to wind (turbine) electric systems that consist of one or more wind electric generators and their related alternators, generators, inverters, controllers, and associated equipment.

Informational Note: Some wind electric systems are interactive with other electric power sources (see Informational Note Figure 694.1). Some systems have ac output and some have dc output. Some systems contain electrical energy storage, such as batteries.

**Informational Note Figure 694.1 Identification of Wind Electric System Components — Interactive System.**



**694.7 Construction and Maintenance.**

The construction and maintenance, associated wiring, and interconnections shall be performed only by qualified persons.

Informational Note: See Article 100 for the definition of *qualified person*.

**694.7(A) Wind Electric Systems.**

A wind electric system(s) shall be permitted to supply a building or other structure in addition to other sources of supply. These requirements apply to both onshore and offshore installations.

**694.7(B) Equipment.**

Wind electric systems shall comply with one of the following:

- (1) Be listed
- (2) Be evaluated for the application and have a field label applied

Wind electric systems undergoing evaluation for type certification and listing shall be permitted to be operated in a controlled location with access limited to qualified personnel.

Informational Note: See UL 6141, *Standard for Wind Turbines Permitting Entry of Personnel*, and UL 6142, *Standard for Small Wind Turbine Systems*, for further information on wind turbine equipment. Ratings for wind turbines could include limitations on installation locations such as onshore or offshore. Testing is typically performed under supervision of a qualified electrical testing organization.

**694.7(C) Diversion Load Controllers.**

A wind electric system employing a diversion load controller as the primary means of regulating the speed of a wind turbine rotor shall be equipped with an additional, independent, reliable means to prevent over-speed operation. An interconnected utility service shall not be considered to be a reliable diversion load.

**694.7(D) Overvoltage Protection.**

A listed surge protective device shall be installed between a wind electric system and any loads served by the premises electrical system. The SPD shall be permitted to be a Type 3 SPD on the circuit serving a wind electric system or a Type 2 SPD located anywhere on the load side of the service disconnect. SPDs shall be installed in accordance with Part II of Article 242.

**694.7(E) Receptacles.**

A receptacle shall be permitted to be supplied by a wind electric system branch or feeder circuit for maintenance or data acquisition use. Receptacles shall be protected with an overcurrent device with a rating not to exceed the current rating of the receptacle. In addition to the requirements in 210.8, all 125-volt, single-phase, 15- and 20-ampere

receptacles installed for maintenance of the wind turbine shall have ground-fault circuit-interrupter protection for personnel.

**694.7(F) Poles or Towers Supporting Wind Turbines Used as a Raceway.**

A pole or tower shall be permitted to be used as a raceway if approved in accordance with one of the following:

- (1) Be evaluated as part of the listing for the wind turbine
- (2) Be listed for the application
- (3) Be evaluated for the application and have a field label applied

**694.7(G) Working Clearances.**

Working space shall be provided for electrical cabinets and other electrical equipment in accordance with 110.26(A).

For large wind turbines where service personnel enter the equipment, where conditions of maintenance and supervision ensure that only qualified persons perform the work, working clearances shall be permitted to comply with Table 694.7(G) for systems up to 1000 volts nominal.

**Table 694.7(G) Working Spaces**

<b><u>Nominal Voltage to Ground</u></b>	<b><u>Condition 1</u></b>	<b><u>Condition 2</u></b>	<b><u>Condition 3</u></b>
<u>0-150</u>	<u>900 mm (3ft)</u>	<u>900 mm (3ft)</u>	<u>900 mm (3ft)</u>
<u>151-1000</u>	<u>900 mm (3ft)</u>	<u>1.0 m (3ft 6in)</u>	<u>1.2 m (4ft)</u>

**Part II. Circuit Requirements**

**694.10 Maximum Voltage.**

**694.10(A) Wind Turbine Output Circuits.**

Wind turbine output circuits on or in one- and two-family dwellings shall be permitted to have a maximum voltage up to 600 volts.

**694.10(B) Direct-Current Utilization Circuits.**

The voltage of dc utilization circuits shall comply with 210.6.

**694.10(C) Circuits over 150 Volts to Ground.**

In one- and two-family dwellings, live parts in circuits over 150 volts to ground shall not be accessible to other than qualified persons while energized.

Informational Note: See 110.27 for guarding of live parts and 210.6 for branch circuit voltage limitations.

**694.12 Circuit Sizing and Current.**

**694.12(A) Calculation of Maximum Circuit Current.**

The maximum current for a circuit shall be calculated in accordance with 694.12(A)(1) through (A)(3).

**694.12(A)(1) Turbine Output Circuit Currents.**

The maximum current shall be based on the circuit current of the wind turbine operating at maximum output power.

**694.12(A)(2) Inverter Output Circuit Current.**

The maximum output current shall be the inverter continuous output current rating.

**694.12(A)(3) Stand-Alone Inverter Input Circuit Current.**

The maximum input current shall be the stand-alone continuous inverter input current rating of the inverter producing rated power at the lowest input voltage.

**694.12(B) Ampacity and Overcurrent Device Ratings.**

**694.12(B)(1) Continuous Current.**

Wind turbine electric system currents shall be considered to be continuous.

**694.12(B)(2) Sizing of Conductors and Overcurrent Devices.**

Circuit conductors and overcurrent devices shall be sized to carry not less than 125 percent of the maximum current as calculated in 694.12(A). The rating or setting of overcurrent devices shall be permitted in accordance with 240.4(B) and (C).

*Exception: Circuits containing an assembly, together with its overcurrent devices, listed for continuous operation at 100 percent of its rating shall be permitted to be used at 100 percent of its rating.*

**694.15 Overcurrent Protection.**

**694.15(A) Circuits and Equipment.**

Turbine output circuits, inverter output circuits, and storage battery circuit conductors and equipment shall be protected in accordance with 240.4 and 240.5. Circuits connected to more than one electrical source shall have overcurrent devices located so as to provide overcurrent protection from all sources.

*Exception: An overcurrent device shall not be required for circuit conductors sized in accordance with 694.12(B) where the maximum current from all sources does not exceed the ampacity of the conductors.*

Informational Note: Possible backfeed of current from any source of supply, including a supply through an inverter to the wind turbine output circuit, is a consideration in determining whether overcurrent protection from all sources is provided. Some wind electric systems rely on the turbine output circuit to regulate turbine speed. Inverters may also operate in reverse for turbine startup or speed control.

**694.15(B) Power Transformers.**

Overcurrent protection for a transformer with sources on each side shall be provided in accordance with 450.3 by considering first one side of the transformer, then the other side of the transformer, as the primary.

*Exception: A power transformer with a current rating on the side connected to the inverter output, which is not less than the rated continuous output current rating of the inverter, shall not be required to have overcurrent protection at the inverter.*

**694.15(C) Direct-Current Rating.**

Overcurrent devices, either fuses or circuit breakers, used in any dc portion of a wind electric system shall be listed for use in dc circuits and shall have appropriate voltage, current, and interrupting ratings.

### **Part III. Disconnecting Means**

#### **694.20 All Conductors.**

Means shall be provided to disconnect all current-carrying conductors of a wind electric power source from all other conductors in a building or other structure. A switch, circuit breaker, or other device, either ac or dc, shall not be installed in a grounded conductor if operation of that switch, circuit breaker, or other device leaves the marked, grounded conductor in an ungrounded and energized state.

*Exception: A wind turbine that uses the turbine output circuit for regulating turbine speed shall not require a turbine output circuit disconnecting means.*

#### **694.22 Additional Provisions.**

Disconnecting means shall comply with 694.22(A) through (D).

#### **694.22(A) Disconnecting Means.**

The disconnecting means shall not be required to be suitable for use as service equipment. The disconnecting means for ungrounded conductors shall consist of manually operable switches or circuit breakers complying with all of the following requirements:

- (1) They shall be located where readily accessible.
- (2) They shall be externally operable without exposing the operator to contact with live parts.
- (3) They shall plainly indicate whether in the open or closed position.
- (4) They shall have an interrupting rating sufficient for the nominal circuit voltage and the current that is available at the line terminals of the equipment.

Where all terminals of the disconnecting means are capable of being energized in the open position, a warning sign shall be mounted on or adjacent to the disconnecting means. The sign shall be clearly legible and shall have the following words or equivalent:

#### **WARNING.**

**ELECTRIC SHOCK HAZARD. DO NOT TOUCH TERMINALS. TERMINALS ON BOTH THE LINE AND LOAD SIDES MAY BE ENERGIZED IN THE OPEN POSITION.**

The warning sign(s) or label(s) shall comply with 110.21(B).

#### **694.22(B) Equipment.**

Equipment such as rectifiers, controllers, output circuit isolating and shorting switches, and over-current devices shall be permitted on the wind turbine side of the disconnecting means.

#### **694.22(C) Requirements for Disconnecting Means.**

##### **694.22(C)(1) Location.**

The wind electric system disconnecting means shall be installed at a readily accessible location either on or adjacent to the turbine tower, on the outside of a building or structure, or inside at the point of entrance of the wind system conductors.

*Exception: Installations that comply with 694.30(C) shall be permitted to have the disconnecting means located remotely from the point of entry of the wind system conductors.*

A wind turbine disconnecting means shall not be required to be located at the nacelle or tower.

The disconnecting means shall not be installed in bathrooms.

For one-family and two-family dwellings, a disconnecting means or manual shutdown button or switch shall be located at a readily accessible location outside the building.

#### **694.22(C)(2) Marking.**

Each turbine system disconnecting means shall be permanently marked to identify it as a wind electric system disconnect.

#### **694.22(C)(3) Suitable for Use.**

Turbine system disconnecting means shall be suitable for the prevailing conditions.

#### **694.22(C)(4) Maximum Number of Disconnects.**

The turbine disconnecting means shall consist of not more than six switches or six circuit breakers mounted in a single enclosure, in a group of separate enclosures, or in or on a switchgear.

#### **694.22(D) Equipment That Is Not Readily Accessible.**

Rectifiers, controllers, and inverters shall be permitted to be mounted in nacelles or other exterior areas that are not readily accessible.

#### **694.23 Turbine Shutdown.**

##### **694.23(A) Manual Shutdown.**

Wind turbines shall be required to have a readily accessible manual shutdown button or switch. Operation of the button or switch shall result in a parked turbine state that shall either stop the turbine rotor or allow limited rotor speed combined with a means to de-energize the turbine output circuit.

*Exception: Turbines with a swept area of less than 50 m<sup>2</sup> (538 ft<sup>2</sup>) shall not be required to have a manual shutdown button or switch.*

##### **694.23(B) Shutdown Procedure.**

The shutdown procedure for a wind turbine shall be defined and permanently posted at the location of a shutdown means and at the location of the turbine controller or disconnect, if the location is different.

#### **694.24 Disconnection of Wind Electric System Equipment.**

Means shall be provided to disconnect equipment, such as inverters, batteries, and charge controllers, from all ungrounded conductors of all sources. If the equipment is energized from more than one source, the disconnecting means shall be grouped and identified.

A single disconnecting means in accordance with 694.22 shall be permitted for the combined ac output of one or more inverters.

A shorting switch or plug shall be permitted to be used as an alternative to a disconnect in systems that regulate turbine speed using the turbine output circuit.

Exception: Equipment housed in a turbine nacelle shall not be required to have a disconnecting means.

#### **694.26 Fuses.**

Means shall be provided to disconnect a fuse from all sources of supply where the fuse is energized from both directions and is accessible to other than qualified persons. Switches, pullouts, or similar devices that are rated for the application shall be permitted to serve as a means to disconnect fuses from all sources of supply.

#### **694.28 Installation and Service of a Wind Turbine.**

Open circuiting, short circuiting, or mechanical brakes shall be used to disable a turbine for installation and service.

Informational Note: Some wind turbines rely on the connection from the alternator to a remote controller for speed regulation. Opening turbine output circuit conductors may cause mechanical damage to a turbine and create excessive voltages that could damage equipment or expose persons to electric shock.

### **Part IV. Wiring Methods**

#### **694.30 Permitted Methods.**

##### **694.30(A) Wiring Systems.**

In addition to wiring methods included in Chapter 3 of this Code, wiring methods and fittings specifically intended listed and identified for use on wind turbines shall be permitted. In readily accessible locations, turbine output circuits that operate at voltages greater than 30 volts shall be installed in raceways.

##### **694.30(B) Flexible Cords and Cables.**

Flexible cords and cables, where used to connect the moving parts of turbines or where used for ready removal for maintenance and repair, shall comply with Article 400 and shall be of a type identified as hard service cord or portable power cable, shall be suitable for extra-hard usage, shall be listed for outdoor use, and shall be water resistant. Cables exposed to sunlight shall be sunlight resistant. Flexible, fine-stranded cables shall be terminated only with terminals, lugs, devices, or connectors in accordance with 110.14(A).

##### **694.30(C) Direct-Current Turbine Output Circuits Inside a Building.**

Direct-current turbine output circuits installed inside a building or structure shall be enclosed in metal raceways or installed in metal enclosures, or run in Type MC metal-clad cable that complies with 250.118(A)(10), from the point of penetration of the surface of the building or structure to the first readily accessible disconnecting means.

### **Part V. Grounding and Bonding**

#### **694.40 Equipment Grounding and Bonding.**

##### **694.40(A) General.**

Exposed non-current-carrying metal parts of towers, turbine nacelles, other equipment, and conductor enclosures shall be grounded and bonded to the premises grounding and bonding system. Attached metal parts, such as turbine blades and tails that are not likely to become energized, shall not be required to be grounded or bonded.

**694.40(B) Tower Grounding and Bonding.**

**694.40(B)(1) Grounding Electrodes and Grounding Electrode Conductors.**

A wind turbine tower shall be connected to a grounding electrode system. Where installed in close proximity to galvanized foundation or tower anchor components, galvanized grounding electrodes shall be used.

Informational Note: Copper and copper-clad grounding electrodes, where used in highly conductive soils, can cause electrolytic corrosion of galvanized foundation and tower anchor components.

**694.40(B)(2) Bonding Conductor.**

Equipment grounding conductors or supply-side bonding jumpers, as applicable, shall be required between turbines, towers, and the premises grounding system.

**694.40(B)(3) Tower Connections.**

Equipment grounding, bonding, and grounding electrode conductors, where used, shall be connected to metallic towers using listed means. All mechanical elements used to terminate these conductors shall be accessible.

**694.40(B)(4) Guy Wires.**

Guy wires used to support turbine towers shall not be required to be connected to an equipment grounding conductor or to comply with the requirements of 250.110.

Informational Note: Guy wires supporting grounded towers are unlikely to become energized under normal conditions, but partial lightning currents could flow through guy wires when exposed to a lightning environment. Grounding of metallic guy wires may be required by lightning standards. See NFPA 780-2017, *Standard for the Installation of Lightning Protection Systems*, for information on lightning protection systems.

**Part VI. Marking**

**694.52 Power Systems Employing Energy Storage.**

Wind electric systems employing energy storage shall be marked with the maximum operating voltage, any equalization voltage, and the polarity of the grounded circuit conductor.

**694.54 Identification of Power Sources.**

Wind turbine systems shall be marked with a plaque or directory installed in accordance with 705.10.

**694.56 Instructions for Disabling Turbine.**

A plaque shall be installed at or adjacent to the turbine location providing basic instructions for disabling the turbine.

**Part VII. Connection to Other Sources**

**694.60 Identified Interactive Equipment.**

Only inverters that are listed, labeled, and identified as interactive shall be permitted in interactive systems.

**694.62 Installation.**

Wind electric systems connected to other sources shall be installed in accordance with Parts I and II of Article 705.

**694.66 Operating Voltage Range.**

Wind electric systems connected to dedicated branch or feeder circuits shall be permitted to exceed normal voltage operating ranges on these circuits, provided that the voltage at any distribution equipment supplying other loads remains within normal ranges.

Informational Note: Wind turbines might use the electric grid to dump energy from short-term wind gusts. See ANSI C84.1-2006, *Voltage Ratings for Electric Power Systems and Equipment (60 Hz)*, for information on normal operating voltages.

**ARTICLE 705 Interconnected Electric Power Production Sources**

**Part I. General**

**705.1 Scope.**

This article covers installation of one or more electric power production sources operating in parallel with a primary source(s) of electricity.

Informational Note No. 1: Examples of the types of primary sources include a utility supply or an on-site electric power source(s).

Informational Note No. 2: See Informational Note Figure 705.1.

**Informational Note Figure 705.1 Identification of Power Source Components in Common Configurations**

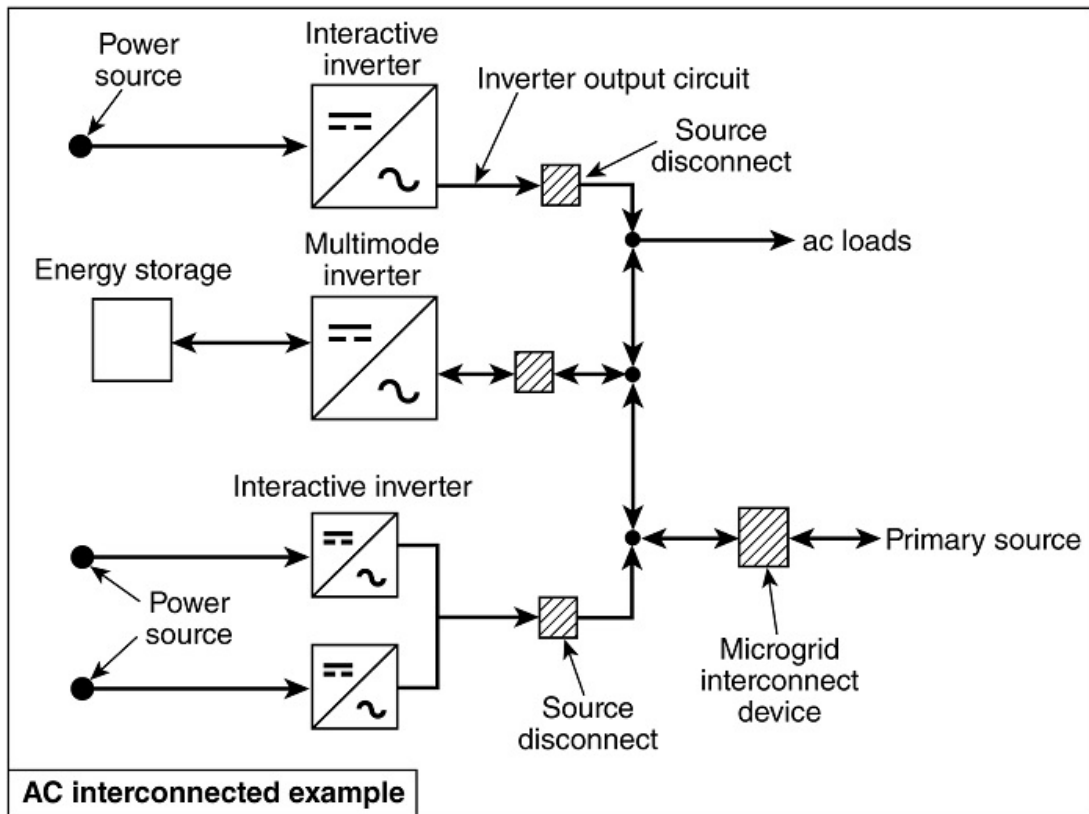
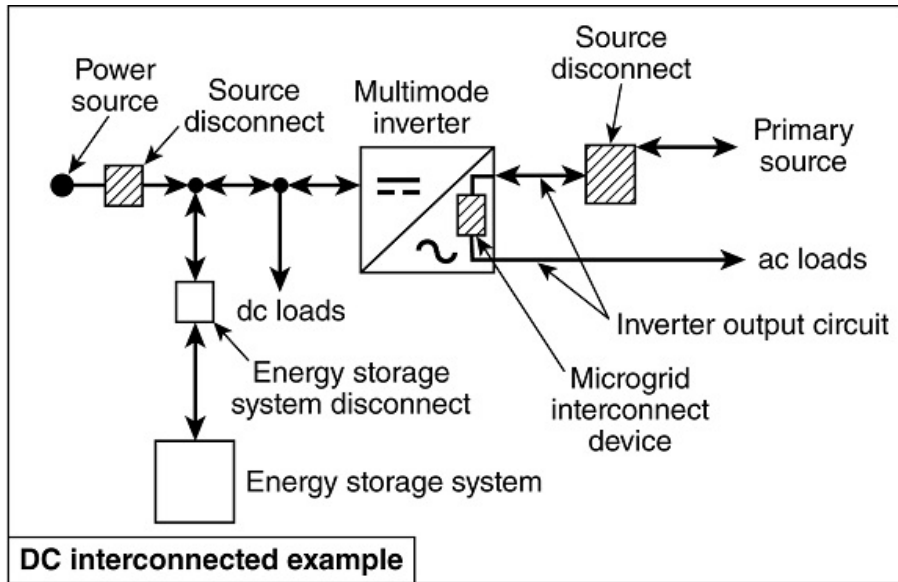

**Notes:**

- (1) These diagrams are intended to be a means of identification for power source components, circuits, and connections.
- (2) The power source disconnect in these diagrams separates the power source from other systems.
- (3) Equipment disconnecting means not shown.
- (4) System grounding and equipment grounding are not shown.
- (5) Custom designs occur in each configuration, and some components are optional.

## **705.5 Parallel Operation.**

### **705.5(A) Output Compatibility.**

Power production sources operating in parallel with a primary source of electricity or other power production sources shall have compatible voltage, wave shape, and frequency ratings.

### **705.5(B) Synchronous Generators.**

Synchronous generators operating in parallel with a primary power source shall be installed with the required synchronizing equipment.

Informational Note: See IEEE 1547, *Standard for Interconnection and Interoperability of Distributed Energy Resources with Associated Electric Power Systems Interfaces*, and UL 1741, *Standard for Inverters, Converters, Controllers and Interconnection System Equipment for Use with Distributed Energy Resources*, for utility interconnection.

## **705.6 Equipment Approval.**

Interconnection and interactive equipment intended to connect to or operate in parallel with power production sources shall be listed for the required interactive function or be evaluated for the interactive function and have a field label applied, or both.

Informational Note No. 1: See UL 1741, *Standard for Inverters, Converters, Controllers and Interconnection System Equipment for Use with Distributed Energy Resources*, for evaluating interconnected equipment. Sources identified as stand-alone, interactive, or multimode are specifically identified and certified to operate in these operational modes. Stand-alone sources operate in island mode, interactive sources operate in interactive mode, and multimode sources operate in either island mode or interactive mode. Stand-alone sources are not evaluated for interactive capabilities.

Informational Note No. 2: An interactive function is common in equipment such as microgrid interconnect devices, power control systems, interactive inverters, synchronous engine generators, ac energy storage systems, and ac wind turbines.

## **705.8 System Installation.**

Installation of one or more electrical power production sources operating in parallel with a primary source(s) of electricity shall be performed only by qualified persons.

Informational Note: See Article 100 for the definition of *Qualified Person*.

## **705.10 Identification of Power Sources.**

Permanent plaques, labels, or directories shall be installed at each service equipment location, or at an approved readily visible location in accordance with the following:

- (1) Denote the location of each power source disconnecting means for the building or structure.

*Exception: Installations with multiple colocated power production sources shall be permitted to be identified as a group(s). The plaque, label, or directory shall not be required to identify each power source individually.*

- (2) Indicate the emergency telephone numbers of any off-site entities servicing the power source systems.

Informational Note: See NFPA 1-2021, *Fire Code*, 11.12.2.1.5 for installer information.

- (3) Be marked with the wording “CAUTION: MULTIPLE SOURCES OF POWER.” The marking shall comply with 110.21(B).

## **705.11 Source Connections to a Service.**

### **705.11(A) Service Connections.**

An electric power production source shall be permitted to be connected to a service by one of the following methods:

- (1) To a new service in accordance with 230.2(A)
- (2) To the supply side of the service disconnecting means in accordance with 230.82(6)
- (3) To an additional set of service entrance conductors in accordance with 230.40, Exception No. 5 These connections shall comply with 705.11(B) through (F).

### **705.11(B) Conductors.**

Service conductors connected to power production sources shall comply with the following:

- (1) The ampacity of the service conductors connected to the power production source service disconnecting means shall not be less than the sum of the power production source maximum circuit current in 705.28(A).
- (2) The service conductors connected to the power production source service disconnecting means shall be sized in accordance with 705.28 and not be smaller than 6 AWG copper or 4 AWG aluminum or copper-clad aluminum.
- (3) The ampacity of any other service conductors to which the power production sources are connected shall not be less than that required in 705.11(B).

### **705.11(C) Connections.**

Connections to service conductors or equipment shall comply with 705.11(C)(1) through (C)(3).

#### **705.11(C)(1) Splices or Taps.**

Service conductor splices and taps shall be made in accordance with 230.33 or 230.46 and comply with all applicable enclosure fill requirements.

#### **705.11(C)(2) Existing Equipment.**

Any modifications to existing equipment shall be made in accordance with the manufacturer's instructions, or the modification must be field evaluated for the application and be field labeled.

#### **705.11(C)(3) Utility-Controlled Equipment.**

For meter socket enclosures or other equipment under the exclusive control of the electric utility, only connections approved by the electric utility shall be permitted.

### **705.11(D) Service Disconnecting Means.**

A disconnecting means in accordance with Parts VI through VII of Article 230 shall be provided to disconnect all ungrounded conductors of a power production source from the conductors of other systems.

### **705.11(E) Bonding and Grounding.**

All metal enclosures, metal wiring methods, and metal parts associated with the service connected to a power production source shall be bonded in accordance with Parts II through V and VIII of Article 250.

**705.11(F) Overcurrent Protection.**

The power production source service conductors shall be protected from overcurrent in accordance with Part VII of Article 230. The rating of the overcurrent protection device of the power production source service disconnecting means shall be used to determine if ground-fault protection of equipment is required in accordance with 230.95.

**705.12 Load-Side Source Connections.**

The output of an interconnected electric power source shall be permitted to be connected to the load side of the service disconnecting means of the other source(s) at any distribution equipment on the premises. Where distribution equipment or feeders are fed simultaneously by a primary source of electricity and one or more other power source(s), the feeders or distribution equipment shall comply with relevant sections of 705.12(A) and (B). Currents from power source connections to feeders or busbars shall be based on the maximum circuit currents calculated in 705.28(A). The ampacity of feeders and taps shall comply with 705.12(A), and the ampere ratings of busbars shall comply with 705.12(B).

**705.12(A) Feeders and Feeder Taps.**

Where the power source output connection is made to a feeder, the following shall apply:

- (1) The feeder ampacity is greater than or equal to 125 percent of the power-source output circuit current.
- (2) Where the power-source output connection is made at a location other than the opposite end of the feeder from the primary source overcurrent device, that portion of the feeder on the load side of the power source output connection shall be protected by one of the following:
  1. a. The feeder ampacity shall be not less than the sum of the rating of the primary source overcurrent device and 125 percent of the power-source output circuit current.
  2. b. An overcurrent device at the load side of the power source connection point shall be rated not greater than the ampacity of the feeder.
- (3) For taps sized in accordance with 240.21(B)(2) or (B)(4), the ampacity of taps conductors shall not be less than one-third of the sum of the rating of the overcurrent device protecting the feeder plus the ratings of any power source overcurrent devices connected to the feeder.

**705.12(B) Busbars.**

For power source connections to distribution equipment with no specific listing and instructions for combining multiple sources, one of the following methods shall be used to determine the required ampere ratings of busbars:

- (1) The sum of 125 percent of the power source(s) output circuit current and the rating of the overcurrent device protecting the busbar shall not exceed the busbar ampere rating.

Informational Note: This general rule assumes no limitation in the number of the loads or sources applied to busbars or their locations.

- (2) Where two sources, one a primary power source and the other another power source, are located at opposite ends of a busbar that contains loads, the sum of 125 percent of the power-source(s) output circuit current and the rating of the overcurrent device protecting the busbar shall not exceed 120 percent of the busbar ampere rating. The busbar shall be sized for the loads connected in accordance with Article 220. A permanent warning label shall be applied to the distribution equipment adjacent to the back-fed breaker from the power source that displays the following or equivalent wording:

**WARNING:**

**POWER SOURCE OUTPUT DO NOT RELOCATE THIS OVERCURRENT DEVICE.**

The warning sign(s) or label(s) shall comply with 110.21(B).

(3) The sum of the ampere ratings of all overcurrent devices on panelboards, both load and supply devices, excluding the rating of the overcurrent device protecting the busbar, shall not exceed the ampacity of the busbar. The rating of the overcurrent device protecting the busbar shall not exceed the rating of the busbar. Permanent warning labels shall be applied to distribution equipment displaying the following or equivalent wording:

**WARNING:**

**EQUIPMENT FED BY MULTIPLE SOURCES. TOTAL RATING OF ALL OVERCURRENT DEVICES EXCLUDING MAIN SUPPLY OVERCURRENT DEVICE SHALL NOT EXCEED AMPACITY OF BUSBAR.**

The warning sign(s) or label(s) shall comply with 110.21(B).

(4) A connection at either end of a center-fed panelboard in dwellings shall be permitted where the sum of 125 percent of the power-source(s) output circuit current and the rating of the overcurrent device protecting the busbar does not exceed 120 percent of the busbar ampere rating.

(5) Connections shall be permitted on busbars of panelboards that supply lugs connected to feed-through conductors or are supplied by feed-through conductors. The feed-through conductors shall be sized in accordance with 705.12(A). Where an overcurrent device is installed at either end of the feed-through conductors, panelboard busbars on either side of the feed-through conductors shall be permitted to be sized in accordance with 705.12(B)(1) through (B)(3).

(6) Connections shall be permitted on switchgear, switchboards, and panelboards in configurations other than those permitted in 705.12(B)(1) through (B)(5) where designed under engineering supervision that includes available fault-current and busbar load calculations.

Informational Note: Specifically designed equipment exists, listed to UL 1741, *Inverters, Converters, Controllers and Interconnection System Equipment for Use With Distributed Energy Resources*, for the combination and distribution of sources to supply loads. The options provided in 705.12(B) are for equipment with no specific listing for combining sources.

**705.13 Energy Management Systems (EMS).**

An EMS in accordance with 750.30 shall be permitted to limit current and loading on the busbars and conductors supplied by the output of one or more interconnected electric power production or energy storage sources.

Informational Note: A listed power control system (PCS) is a type of EMS that is capable of monitoring multiple power sources and controlling the current on busbars and conductors to prevent overloading. See UL 1741, *Inverters, Converters, Controllers and Interconnection System Equipment for Use with Distributed Energy Resources*, and UL 916, *Energy Management Equipment*, for information on PCS and EMS.

**705.20 Source Disconnecting Means.**

Means shall be provided to disconnect power source output conductors of electric power production equipment from conductors of other systems. A single disconnecting means shall be permitted to disconnect multiple power sources from conductors of other systems.

Informational Note: See 480.7, Part II of Article 445, Part III of Article 690, Part III of Article 692, Part III of Article 694, and Part II of Article 706 for specific source disconnecting means requirements.

The disconnecting means shall comply with the following:

- (1) Be one of the following types:
  1. a. A manually operable switch or circuit breaker
  2. b. A load-break-rated pull-out switch
  3. c. A power-operated or remote-controlled switch or circuit breaker that is manually operable locally and opens automatically when control power is interrupted
  4. d. A device listed or approved for the intended application
- (2) Simultaneously disconnect all ungrounded conductors of the circuit
- (3) Located where readily accessible
- (4) Externally operable without exposed live parts
- (5) Plainly indicate whether in the open (off) or closed (on) position
- (6) Have ratings sufficient for the maximum circuit current, available fault current, and voltage that is available at the terminals
- (7) Where the line and load terminals are capable of being energized in the open position, be marked with the following words or equivalent:

**WARNING**

**ELECTRIC SHOCK HAZARD TERMINALS ON THE LINE AND LOAD SIDES MAY BE ENERGIZED IN THE OPEN POSITION.**

Informational Note: With interconnected power sources, some equipment, including switches and fuses, is capable of being energized from both directions.

**705.25 Wiring Methods.**

Power source output conductors shall comply with 705.25(A) through (C).

**705.25(A) General.**

Wiring methods and fittings listed for use with power production systems shall be permitted in addition to general wiring methods and fittings permitted elsewhere in this Code.

**705.25(B) Flexible Cords and Cables.**

Flexible cords and cables, where used to connect the moving parts of power production equipment, or where used for ready removal for maintenance and repair, shall be listed and identified as DG cable, or other cable suitable for extra hard use, and shall be water resistant. Cables exposed to sunlight shall be sunlight resistant. Flexible, fine-stranded cables shall be terminated only with terminals, lugs, devices, or connectors in accordance with 110.14(A).

**705.25(C) Multiconductor Cable Assemblies.**

Multiconductor cable assemblies used in accordance with their listings shall be permitted.

Informational Note: See UL 3003, *Distributed Generation Cables*, and UL 9703, *Outline of Investigation for Distributed Generation Wiring Harnesses*, for additional information on DG cable (distributed generation cable) and harnesses. An ac module harness is one example of a multiconductor cable assembly.

## **705.28 Circuit Sizing and Current.**

### **705.28(A) Power Source Output Maximum Current.**

Where not elsewhere required or permitted in this Code, the maximum current for power sources shall be calculated using one of the following methods:

- (1) The sum of the continuous output current ratings of the power production equipment at the circuit nominal system voltage
- (2) For power production equipment controlled by an EMS, the current setpoint of the EMS
- (3) Where sources controlled by an EMS are combined with other sources on the same power source output circuit, the sum of 705.28(A)(1) and (A)(2)

### **705.28(B) Conductor Ampacity.**

Where not elsewhere required or permitted in this Code, the power source output conductors shall have an ampacity not less than the larger of the following and comply with 110.14(C):

- (1) The maximum currents in 705.28(A) multiplied by 125 percent without adjustment or correction factors

*Exception No. 1: If the assembly, including the overcurrent devices protecting the circuit, is listed for operation at 100 percent of its rating, the ampacity of the conductors shall be permitted to be not less than the calculated maximum current of 705.28(A).*

*Exception No. 2: Where a portion of a circuit is connected at both its supply and load ends to separately installed pressure connections as covered in 110.14(C)(2), it shall be permitted to have an ampacity not less than the calculated maximum current of 705.28(A). No portion of the circuit installed under this exception shall extend into an enclosure containing either the circuit supply or the circuit load terminations, as covered in 110.14(C)(1).*

*Exception No. 3: Grounded conductors that are not connected to an overcurrent device shall be permitted to be sized at 100 percent of the calculated maximum current of 705.28(A).*

- (2) The maximum currents in 705.28(A) after the application of adjustment and correction factors in accordance with 310.14
- (3) Where connected to feeders, if smaller than the feeder conductors, the ampacity as calculated in 240.21(B) based on the over-current device protecting the feeder

### **705.28(C) Neutral Conductors.**

Neutral conductors shall be permitted to be sized in accordance with either 705.28(C)(1) or (C)(2).

#### **705.28(C)(1) Single-Phase Line-to-Neutral Power Sources.**

Where not elsewhere required or permitted in this Code, the ampacity of a neutral conductor to which a single-phase line-to-neutral power source is connected shall not be smaller than the ampacity in 705.28(B).

#### **705.28(C)(2) Neutral Conductor Used Solely for Instrumentation, Voltage, Detection, or Phase Detection.**

A power production equipment neutral conductor used solely for instrumentation, voltage detection, or phase detection shall be permitted to be sized in accordance with 250.102.

### **705.30 Overcurrent Protection.**

#### **705.30(A) Circuit and Equipment.**

Power source output conductors and equipment shall be provided with overcurrent protection. Circuits connected to more than one electrical source shall have overcurrent devices located to provide overcurrent protection from all sources.

#### **705.30(B) Overcurrent Device Ratings.**

The overcurrent devices in other than generator systems shall be sized to carry not less than 125 percent of the maximum currents as calculated in 705.28(A). The rating or setting of overcurrent devices shall be permitted in accordance with 240.4(B) and (C).

*Exception: Circuits containing an assembly together with its overcurrent device(s) that is listed for continuous operation at 100 percent of its rating shall be permitted to be utilized at 100 percent of its rating.*

#### **705.30(C) Marking.**

Equipment containing overcurrent devices supplied from interconnected power sources shall be marked to indicate the presence of all sources.

#### **705.30(D) Suitable for Backfeed.**

Fused disconnects, unless otherwise marked, shall be considered suitable for backfeed. Circuit breakers not marked "line" and "load" shall be considered suitable for backfeed. Circuit breakers marked "line" and "load" shall be considered suitable for backfeed or reverse current if specifically rated.

#### **705.30(E) Fastening.**

Listed plug-in-type circuit breakers backfed from electric power sources that are listed and identified as interactive shall be permitted to omit the additional fastener normally required by 408.36(D) for such applications.

#### **705.30(F) Transformers.**

The following apply to the installation of transformers:

- (1) For the purpose of overcurrent protection, the primary side of transformers with sources on each side shall be the side connected to the largest source of available fault current.
- (2) Transformer secondary conductors shall be protected in accordance with 240.21(C).

### **705.32 Ground-Fault Protection.**

Where ground-fault protection of equipment is installed in ac circuits as required elsewhere in this Code, the output of interconnected power production equipment shall be connected to the supply side of the ground-fault protection equipment.

*Exception: Connection of power production equipment shall be permitted to be made to the load side of ground-fault protection equipment where installed in accordance with 705.11 or where there is ground-fault protection for equipment from all ground-fault current sources.*

### **705.40 Loss of Primary Source.**

The output of interactive electric power production equipment shall be automatically disconnected from all ungrounded conductors of the primary source when one or more of the phases of the primary source to which it is connected opens. The interactive electric power production equipment shall not be reconnected to the primary source until all the phases of the primary source to which it is connected are restored. This requirement shall

not be applicable to electric power production equipment providing power to an emergency or legally required standby system.

*Exception: A listed interactive inverter shall trip or shall be permitted to automatically cease exporting power when one or more of the phases of the interconnected primary source opens and shall not be required to automatically disconnect all ungrounded conductors from the primary source. A listed interactive inverter shall be permitted to automatically or manually resume exporting power to the interconnected system once all phases of the source to which it is connected are restored.*

Informational Note No. 1: Risks to personnel and equipment associated with the primary source could occur if an interactive electric power production source can operate as an intentional island. Special detection methods are required to determine that a primary source supply system outage has occurred and whether there should be automatic disconnection. When the primary source supply system is restored, special detection methods are typically required to limit exposure of power production sources to out-of-phase reconnection.

Informational Note No. 2: Induction-generating equipment connected on systems with significant capacitance can become self-excited upon loss of the primary source and experience severe overvoltage as a result.

Interactive power production equipment shall be permitted to operate in island mode to supply loads that have been disconnected from the electric utility or other electric power production and distribution network.

#### **705.45 Unbalanced Interconnections.**

##### **705.45(A) Single Phase.**

Single-phase power sources in interactive systems shall be connected to 3-phase power systems in order to limit unbalanced voltages at the point of interconnection to not more than 3 percent.

Informational Note: For interactive power sources, unbalanced voltages can be minimized by the same methods that are used for single-phase loads on a 3-phase power system. See ANSI/C84.1-2016, *Electric Power Systems and Equipment — Voltage Ratings (60 Hertz)*.

##### **705.45(B) Three Phase.**

Three-phase power sources in interactive systems shall have all phases automatically de-energized upon loss of, or unbalanced, voltage in one or more phases unless the interconnected system is designed so that significant unbalanced voltages will not result.

## **Part II. Microgrid Systems**

#### **705.50 System Operation.**

Interconnected microgrid systems shall be capable of operating in interactive mode with a primary source of power, or electric utility, or other electric power production and distribution network. Microgrid systems shall be permitted to disconnect from other sources and operate in island mode.

Informational Note No. 1: Microgrid systems often include a single source or a compatible interconnection of multiple sources such as engine generators, solar PV, wind, or ESS.

Informational Note No. 2: See Article 517 for health care facilities incorporating microgrids.

#### **705.60 Primary Power Source Connection.**

Connections to primary power sources that are external to the microgrid system shall comply with the requirements of 705.11, 705.12, or 705.13. Power source conductors



## **ARTICLE 706 Energy Storage Systems**

### **Part I. General**

#### **706.1 Scope.**

This article applies to all energy storage systems (ESS) having a capacity greater than 3.6 MJ (1 kWh) that may be stand-alone or interactive with other electric power production sources. These systems are primarily intended to store and provide energy during normal operating conditions.

Informational Note No. 1: See Article 480 for installations that meet the definition of *stationary standby batteries*.

Informational Note No. 2: For batteries rated in ampere hours, kWh is equal to the nominal rated voltage times ampere-hour rating divided by 1000.

Informational Note No. 3: The following standards are frequently referenced for the installation of ESSs:

- (1) NFPA 1-2021, *Fire Code*
- (2) NFPA 111-2019, *Standard on Stored Electrical Energy Emergency and Standby Power Systems*
- (3) NECA 416-2016, *Recommended Practice for Installing Energy Storage Systems (ESS)*
- (4) UL 810A, *Electrochemical Capacitors*
- (5) NFPA 855-2020, *Standard for the Installation of Stationary Energy Storage Systems*
- (6) UL 1973, *Standard for Batteries for Use in Stationary, Vehicle Auxiliary Power, and Light Electric Rail (LER) Applications*
- (7) UL 1989, *Standard for Standby Batteries*
- (8) UL 9540, *Standard for Safety Energy Storage Systems and Equipment*
- (9) UL Subject 2436, *Spill Containment For Stationary Lead Acid Battery Systems*

#### **706.3 Qualified Personnel.**

The installation and maintenance of ESS equipment and all associated wiring and interconnections shall be performed only by qualified persons.

Informational Note: See Article 100 for the definition of *qualified person*.

#### **706.4 System Requirements.**

Each ESS shall be provided with a nameplate plainly visible after installation and marked with the following:

- (1) Manufacturer's name, trademark, or other descriptive marking by which the organization responsible for supplying the ESS can be identified
- (2) Rated frequency
- (3) Number of phases, if ac
- (4) Rating (kW or kVA)
- (5) Available fault current derived by the ESS at the output terminals
- (6) Maximum output and input current of the ESS at the output terminals

(7) Maximum output and input voltage of the ESS at the output terminals

(8) Utility-interactive capability, if applicable

**706.5 Listing.**

Energy storage systems shall be listed.

**706.6 Multiple Systems.**

Multiple ESSs shall be permitted to be installed on the same premises.

**706.7 Commissioning and Maintenance.**

**706.7(A) Commissioning.**

ESSs shall be commissioned upon installation. This shall not apply in one- and two-family dwellings.

Informational Note: See NFPA 855-2020, *Standard for the Installation of Stationary Energy Storage Systems*, for information related to the commissioning of ESSs.

**706.7(B) Maintenance.**

ESSs shall be maintained in proper and safe operating condition. The required maintenance shall be in accordance with the manufacturer's requirements and industry standards. A written record of the system maintenance shall be kept and shall include records of repairs and replacements necessary to maintain the system in proper and safe operating condition. This shall not apply in one- and two-family dwellings.

Informational Note: See NFPA 70B-2019, *Recommended Practice for Electrical Equipment Maintenance*, or ANSI/NETA ATS-2017, *Standard for Acceptance Testing Specifications for Electrical Power Equipment and Systems*, for information related to general electrical equipment maintenance and developing an effective electrical preventive maintenance (EPM) program.

**706.9 Maximum Voltage.**

The maximum voltage of an ESS shall be the rated ESS input and output voltage(s) indicated on the ESS nameplate(s) or system listing.

**Part II. Disconnecting Means**

**706.15 Disconnecting Means.**

**706.15(A) ESS Disconnecting Means.**

Means shall be provided to disconnect the ESS from all wiring systems, including other power systems, utilization equipment, and its associated premises wiring.

**706.15(B) Location and Control.**

The disconnecting means shall be readily accessible and shall comply with one or more of the following:

(1) Located within the ESS

(2) Located within sight and within 3 m (10 ft) from the ESS

(3) Where not located within sight of the ESS, the disconnecting means, or the enclosure providing access to the disconnecting means, shall be capable of being locked in accordance with 110.25

Where controls to activate the disconnecting means of an ESS are used and are not located within sight of the ESS, the disconnecting means shall be lockable in accordance with 110.25, and the location of the controls shall be marked on the disconnecting means.

For one- and two-family dwellings, an ESS shall include an emergency shutdown function to cease the export of power from the ESS to premises wiring of other systems. An initiation device(s) shall be located at a readily accessible location outside the building and shall plainly indicate whether in the "off" or "on" position. The "off" position of the device(s) shall perform the ESS emergency shutdown function.

**706.15(C) Notification and Marking.**

Each ESS disconnecting means shall plainly indicate whether it is in the open (off) or closed (on) position and be permanently marked as follows:

“ENERGY STORAGE SYSTEM DISCONNECT”

The disconnecting means shall be legibly marked in the field to indicate the following:

- (1) Nominal ESS output voltage
- (2) Available fault current derived from the ESS
- (3) An arc-flash label applied in accordance with acceptable industry practice
- (4) Date the calculation was performed

*Exception: List items (2), (3), and (4) shall not apply to one- and two-family dwellings.*

Informational Note No. 1: See NFPA 70E-2018, *Standard for Electrical Safety in the Workplace*, for industry practices for equipment labeling. This standard provides specific criteria for developing arc-flash labels for equipment that provides nominal system voltage, incident energy levels, arc-flash boundaries, minimum required levels of personal protective equipment, and so forth.

Informational Note No. 2: ESS electronics could include inverters or other types of power conversion equipment.

For ESS disconnecting means where the line and load terminals could be energized in the open position, the device shall be marked with the following words or equivalent:

**WARNING**  
**ELECTRIC** **SHOCK** **HAZARD**  
**TERMINALS ON THE LINE AND LOAD SIDES MAY BE ENERGIZED IN THE**  
**OPEN POSITION**

The notification(s) and marking(s) shall comply with 110.21(B).

**706.15(D) Partitions Between Components.**

Where circuits from the input or output terminals of energy storage components in an ESS pass through a wall, floor, or ceiling, a readily accessible disconnecting means shall be provided within sight of the energy storage component. Fused disconnecting means or circuit breakers shall be permitted to be used.

**706.15(E) Disconnecting Means for Batteries.**

In cases where the battery is separate from the ESS electronics and is subject to field servicing, 706.15(E)(1) through (E)(4) shall apply.

Informational Note: Batteries could include an enclosure, battery monitoring and controls, or other related battery components.

**706.15(E)(1) Disconnecting Means.**

A disconnecting means shall be provided for all ungrounded conductors. A disconnecting means shall be readily accessible and located within sight of the battery.

Informational Note: See 240.21(H) for information on the location of the overcurrent device for battery conductors.

**706.15(E)(2) Disconnection of Series Battery Circuits.**

Battery circuits exceeding 240 volts dc nominal between conductors or to ground shall have provisions to disconnect the series-connected strings into segments not exceeding 240 volts dc nominal for maintenance by qualified persons. Non-load-break bolted or plug-in disconnects shall be permitted.

**706.15(E)(3) Remote Activation.**

Where a disconnecting means is provided with remote controls to activate the disconnecting means and the controls for the disconnecting means are not located within sight of the battery, the disconnecting means shall be capable of being locked in the open position, in accordance with 110.25, and the location of the controls shall be field marked on the disconnecting means.

**706.15(E)(4) Notification.**

The disconnecting means shall be legibly marked in the field. The marking shall be of sufficient durability to withstand the environment involved and shall include the following:

(1) Nominal battery voltage

(2) Available fault current derived from the stationary standby battery system

Informational Note No. 1: Battery equipment suppliers can provide information about available fault current on any particular battery model.

(3) An arc-flash label in accordance with acceptable industry practice

Informational Note No. 2: See NFPA 70E-2021, *Standard for Electrical Safety in the Workplace*, for assistance in determining the severity of potential exposure, planning safe work practices, determining arc-flash labeling, and selecting personal protective equipment.

(4) Date the calculation was performed

**706.16 Connection to Energy Sources.**

The connection of an ESS to sources of energy shall comply with 706.16(A) through (F).

**706.16(A) Source Disconnect.**

A disconnect that has multiple sources of power shall disconnect all energy sources when in the off position.

**706.16(B) Identified Interactive Equipment.**

ESS that operate in parallel with other ac sources shall use inverters that are listed and identified as interactive.

**706.16(C) Loss of Interactive System Power.**

Upon loss of a primary source of power, an ESS with a utility-interactive inverter shall comply with the requirements of 705.40.

**706.16(D) Unbalanced Interconnections.**

Unbalanced ac connections between an ESS and other ac electric power production sources shall be in accordance with 705.45

**706.16(E) Other Energy Sources.**

The connection of an ESS to other energy sources shall be in accordance with 705.12.

**706.16(F) Stand-Alone Operation.**

Where the output of an ESS is capable of operating in stand-alone mode, the requirements of 710.15 shall apply.

**Part III. Installation Requirements**

**706.20 General.**

**706.20(A) Ventilation.**

Provisions appropriate to the energy storage technology shall be made for sufficient diffusion and ventilation of any possible gases from the storage device, if present, to prevent the accumulation of an explosive mixture. Ventilation of an ESS shall be permitted to be provided in accordance with the manufacturer's recommendations and listing for the system.

Informational Note No. 1: See NFPA 855-2020, *Standard for the Installation of Stationary Energy Storage Systems*, for technology-specific guidance. Not all ESS technologies require ventilation.

Informational Note No. 2: See IEEE 1635-2018/ASHRAE Guideline 21-2018, *Guide for the Ventilation and Thermal Management of Batteries for Stationary Applications*, as a source for design of ventilation of batteries.

**706.20(B) Dwelling Units.**

An ESS for one- and two-family dwelling units shall not exceed 100 volts dc between conductors or to ground.

Exception: Where live parts are not accessible during routine ESS maintenance, a maximum ESS voltage of 600 volts dc shall be permitted.

**706.20(C) Spaces About ESS Components.**

**706.20(C)(1) General.**

Working spaces for ESS shall comply with 110.26 and 110.34.

**706.20(C)(2) Space Between Components.**

ESSs shall be permitted to have space between components in accordance with the manufacturer's instructions and listing.

Informational Note: Additional space may be needed to accommodate ESS hoisting equipment, tray removal, or spill containment.

**706.21 Directory (Identification of Power Sources).**

ESS shall be indicated by markings or labels that shall be in accordance with 110.21(B).

**706.21(A) Facilities with Utility Services and ESS.**

Plaques or directories shall be installed in accordance with 705.10.

**706.21(B) Facilities with Stand-Alone Systems.**

Plaques or directories shall be installed in accordance with 710.10.

**Part IV. Circuit Requirements**

**706.30 Circuit Sizing and Current.**

**706.30(A) Maximum Rated Current for a Specific Circuit.**

The maximum current for the specific circuit shall be calculated in accordance with 706.30(A)(1) through (A)(5).

**706.30(A)(1) Nameplate-Rated Circuit Current.**

Circuit current shall be the rated current indicated on the ESS nameplate(s) or system listing. Where the ESS has separate input (charge) and output (discharge) circuits or ratings, these shall be considered individually. Where the same terminals on the ESS are used for charging and discharging, the rated current shall be the greater of the two.

**706.30(A)(2) Inverter Output Circuit Current.**

The maximum current shall be the inverter continuous output current rating.

**706.30(A)(3) Inverter Input Circuit Current.**

The maximum current shall be the continuous inverter input current rating when the inverter is producing rated power at the lowest input voltage.

**706.30(A)(4) Inverter Utilization Output Circuit Current.**

The maximum current shall be the continuous ac output current rating of the inverter when the inverter is producing rated power.

**706.30(A)(5) DC to DC Converter Output Current.**

The maximum current shall be the dc-to-dc converter continuous output current rating.

**706.30(B) Conductor Ampacity.**

The ampacity of the output circuit conductors of the ESS(s) connected to the wiring system serving the loads to be serviced by the system shall not be less than the greater of the nameplate(s)-rated circuit current as determined in accordance with 706.30(A)(1) or the rating of the ESS(s) overcurrent protective device(s).

**706.30(C) Ampacity of Grounded or Neutral Conductor.**

If the output of a single-phase, 2-wire ESS output(s) is connected to the grounded or neutral conductor and a single ungrounded conductor of a 3-wire system or of a 3-phase, 4-wire, wye-connected system, the maximum unbalanced neutral load current plus the ESS(s) output rating shall not exceed the ampacity of the grounded or neutral conductor.

**706.31 Overcurrent Protection.**

**706.31(A) Circuits and Equipment.**

Protection devices for ESS circuits shall be in accordance with 706.31(B) through (F). Circuits shall be protected at the source from overcurrent. A circuit conductor connected at one end to a supply with integral fault protection, where the conductor is rated for the maximum circuit current from that supply, and also connected to sources having an available maximum circuit current greater than the ampacity of the conductor, shall be protected from overcurrent at the point of connection to the higher current source.

Informational Note: Listed electronic power converter circuits powered by an ESS have integral fault protection. Where these circuits are connected to higher current sources such as a utility service, the overcurrent device is more appropriately installed at the higher current source end of the circuit conductor.

**706.31(B) Overcurrent Device Ampere Ratings.**

Overcurrent protective devices, where required, shall be not less than 125 percent of the maximum currents calculated in 706.30(A).

Exception: Where the assembly, including the overcurrent protective devices, is listed for operation at 100 percent of its rating, the ampere rating of the overcurrent devices shall be permitted to be not less than the maximum currents calculated in 706.30(B).

**706.31(C) Direct Current Rating.**

Overcurrent protective devices, either fuses or circuit breakers, used in any dc portion of an ESS shall be listed for dc and shall have the appropriate voltage, current, and interrupting ratings for the application.

**706.31(D) Current Limiting.**

A listed and labeled current-limiting overcurrent protective device shall be installed adjacent to the ESS for each dc output circuit.

Exception: Where current-limiting overcurrent protection is provided for the dc output circuits of a listed ESS, additional current-limiting overcurrent devices shall not be required.

**706.31(E) Fuses.**

Means shall be provided to disconnect any fuses associated with ESS equipment and components when the fuse is energized from both directions and is accessible to other than qualified persons. Switches, pullouts, or similar devices that are rated for the application shall be permitted to serve as a means to disconnect fuses from all sources of supply.

**706.31(F) Location.**

Where circuits from the input or output terminals of energy storage components in an ESS pass through a wall, floor, or ceiling, overcurrent protection shall be provided at the energy storage component end of the circuit.

**706.33 Charge Control.**

**706.33(A) General.**

Provisions shall be provided to control the charging process of the ESS. All adjustable means for control of the charging process shall be accessible only to qualified persons.

**706.33(B) Diversion Charge Controller.**

**706.33(B)(1) Sole Means of Regulating Charging.**

An ESS employing a diversion charge controller as the sole means of regulating charging shall be equipped with a second independent means to prevent overcharging of the storage device.

**706.33(B)(2) Circuits with Diversion Charge Controller and Diversion Load.**

Circuits containing a diversion charge controller and a diversion load shall comply with the following:

(1) The current rating of the diversion load shall be less than or equal to the current rating of the diversion load charge controller. The voltage rating of the diversion load shall be greater than the maximum ESS voltage. The power rating of the diversion load shall be at least 150 percent of the power rating of the charging source.

(2) The conductor ampacity and the rating of the overcurrent device for this circuit shall be at least 150 percent of the maximum current rating of the diversion charge controller.

### **706.33(B)(3) ESS Using Interactive Inverters.**

Systems using interactive inverters to control energy storage state-of-charge by diverting excess power into an alternate electric power production and distribution system, such as utility, shall comply with 706.33(B)(3)(a) and (B)(3)(b).

(a) These systems shall not be required to comply with 706.33(B)(2).

(b) These systems shall have a second, independent means of controlling the ESS charging process for use when the alternate system is not available or when the primary charge controller fails or is disabled.

### **706.33(C) Charge Controllers and DC-to-DC Converters.**

Where charge controllers and other DC-to-DC power converters that increase or decrease the output current or output voltage with respect to the input current or input voltage are installed, all of the following shall apply:

(1) The ampacity of the conductors in output circuits shall be based on the maximum rated continuous output current of the charge controller or converter for the selected output voltage range.

(2) The voltage rating of the output circuits shall be based on the maximum voltage output of the charge controller or converter for the selected output voltage range.

## **Part V. Flow Battery ESSs**

Part V applies to ESSs composed of or containing flow batteries.

Informational Note: Due to the unique design features and difference in operating characteristics of flow batteries as compared with that of storage batteries such as lead acid or lithium ion batteries, the requirements for flow batteries have been included herein (Article 706, Part V).

### **706.40 General.**

The system and system components shall also meet Parts I, II, and III of this article.

Informational Note: See NFPA 855-2020, *Standard for the Installation of Stationary Energy Storage Systems*, for installation requirements for ESS, including requirements for flow batteries.

### **706.41 Electrolyte Classification.**

The electrolyte(s) that are acceptable for use in the batteries associated with the ESS shall be identified by name and chemical composition. Such identification shall be provided by readily discernable signage adjacent to every location in the system where the electrolyte can be put into or taken out of the system.

### **706.42 Electrolyte Containment.**

Flow battery systems shall be provided with a means for electrolyte containment to prevent spills of electrolyte from the system. An alarm system shall be provided to signal an electrolyte leak from the system. Electrical wiring and connections shall be located and routed in a manner that mitigates the potential for exposure to electrolytes.

### **706.43 Flow Controls.**

Controls shall be provided to safely shut down the system in the event of electrolyte blockage.

### **706.44 Pumps and Other Fluid Handling Equipment.**

Pumps and other fluid handling equipment are to be rated/specified suitable for exposure to the electrolytes.

## **Part VI. Other Energy Storage Technologies**

Part VI applies to ESSs using other technologies intended to store energy and when there is a demand for electrical power to use the stored energy to generate the needed power.

### **706.50 General.**

All electrical connections to and from the system and system components shall be in accordance with the applicable provisions of this *Code*. The systems shall comply with Parts I, II, III, and IV of this article.

### **706.51 Flywheel ESS (FESS).**

Flywheel ESS (FESS) using flywheels as the storage mechanism shall also comply with all of the following:

(1) FESS shall not be used for one- or two-family dwelling units.

Informational Note No. 1: FESS are intended for high-power shorter term applications. They contain parts that rotate under high speed with hazardous kinetic energy and include parts such as magnetic bearings that require ongoing monitoring and maintenance and, therefore, are not suitable for residential-type applications.

(2) FESS shall be provided with bearing monitoring and controls that can identify bearing wear or damage to avoid catastrophic failure.

Informational Note No. 2: The bearing monitoring controls should be evaluated as part of the listing evaluation.

(3) FESS shall be provided with a containment means to contain moving parts that could break from the system upon catastrophic failure.

Informational Note No. 3: The containment means should be evaluated as part of the listing evaluation.

(4) The spin-down time of the FESS shall be provided in the maintenance documentation.

## **ARTICLE 710 Stand-Alone Systems**

### **710.1 Scope.**

This article covers electric power production systems that operate in island mode not connected to an electric utility or other electric power production and distribution network.

Informational Note: These systems operate independently from an electric utility and include isolated microgrid systems. Stand-alone systems often include a single or a compatible interconnection of sources such as engine generators, solar PV, wind, ESS, or batteries.

### **710.6 Equipment Approval.**

All power production equipment or systems shall be approved for use in island mode and comply with one of the following:

- (1) Be listed
- (2) Be evaluated for the application and have a field label applied

### **710.10 Identification of Power Sources.**

A permanent plaque, label, or directory shall be installed at a building supplied by a stand-alone system at the power source disconnecting means location, or at an approved readily visible location. The plaque, label, or directory shall denote the location of each power source disconnecting means for the building or be grouped with other plaques or directories for other on-site sources. Where multiple sources supply the building, markings shall comply with 705.10.

### **710.12 Stand-Alone Inverter Input Circuit Current.**

The maximum current shall be the stand-alone continuous inverter input current rating when the inverter is producing rated power at the lowest input voltage.

### **710.15 General.**

Premises wiring systems shall be adequate to meet the requirements of this *Code* for similar installations supplied by a feeder or service. The wiring on the supply side of the building or structure disconnecting means shall comply with the requirements of this *Code*, except as modified by 710.15(A) through (G).

#### **710.15(A) Supply Output.**

Power supply to premises wiring systems fed by stand-alone or isolated microgrid power sources shall be permitted to have less capacity than the calculated load. The capacity of the sum of all sources of the stand-alone supply shall be equal to or greater than the load posed by the largest single utilization equipment connected to the system. Calculated general lighting loads shall not be considered as a single load.

Informational Note: For general-use loads the system capacity can be calculated using the sum of the capacity of the firm sources, such as generators and ESS inverters. For specialty loads intended to be powered directly from a variable source, the capacity can be calculated using the sum of the variable sources, such as PV or wind inverters, or the combined capacity of both firm and variable sources.

#### **710.15(B) Sizing and Protection.**

The circuit conductors between a stand-alone source and a building or structure disconnecting means shall be sized based on the sum of the output ratings of the stand-alone source(s). For three-phase interconnections, the phase loads shall be controlled or balanced to be compatible with specifications of the sum of the power supply capacities.

**710.15(C) Single 120-Volt Supply.**

Stand-alone and isolated microgrid systems shall be permitted to supply 120 volts to single-phase, 3-wire, 120/240-volt service equipment or distribution panels where there are no 240-volt outlets and where there are no multiwire branch circuits. In all installations, the sum of the ratings of the power sources shall be less than the rating of the neutral bus in the service equipment. This equipment shall be marked with the following words or equivalent:

**WARNING:**

**SINGLE 120-VOLT SUPPLY. DO NOT CONNECT MULTIWIRE BRANCH CIRCUITS!**

The warning sign(s) or label(s) shall comply with 110.21(B).

**710.15(D) Three-phase Supply.**

Stand-alone and microgrid systems shall be permitted to supply three-phase, 3-wire or 4-wire systems.

**710.15(E) Energy Storage or Backup Power System Requirements.**

Energy storage or backup power supplies shall not be required.

**710.15(F) Voltage and Frequency Control.**

The stand-alone power sources shall be controlled during operation so that voltage and frequency are supplied within limits compatible with the connected loads.

## **ARTICLE 750 Energy Management Systems**

### **750.1 Scope.**

This article applies to the installation and operation of energy management systems.

Informational Note: Performance provisions in other codes establish prescriptive requirements that may further restrict the requirements contained in this article.

### **750.6 Listing.**

Energy management systems shall be one of the following:

- (1) Listed as a complete energy management system
- (2) Listed as a kit for field installation in switch or overcurrent device enclosures
- (3) Listed individual components assembled as a system

### **750.20 Alternate Power Sources.**

An energy management system shall not override any control necessary to ensure continuity of an alternate power source for the following:

- (1) Fire pumps
- (2) Health care facilities
- (3) Emergency systems
- (4) Legally required standby systems
- (5) Critical operations power systems

### **750.30 Load Management.**

Energy management systems shall be permitted to monitor and control electrical loads and sources in accordance with 750.30(A) through (C).

#### **750.30(A) Load Shedding Controls.**

An energy management system shall not override the load shedding controls put in place to ensure the minimum electrical capacity for the following:

- (1) Fire pumps
- (2) Emergency systems
- (3) Legally required standby systems
- (4) Critical operations power systems

#### **750.30(B) Disconnection of Power.**

An energy management system shall not cause disconnection of power to the following:

- (1) Elevators, escalators, moving walks, or stairway lift chairs
- (2) Positive mechanical ventilation for hazardous (classified) locations
- (3) Ventilation used to exhaust hazardous gas or reclassify an area
- (4) Circuits supplying emergency lighting
- (5) Essential electrical systems in health care facilities

#### **750.30(C) Capacity of Branch Circuit, Feeder, or Service.**

An energy management system shall not cause a branch circuit, feeder, or service to be overloaded. If an EMS is used to limit the current on a conductor, 750.30(C)(1) through (C)(4) shall apply:

**750.30(C)(1) Current Setpoint.**

A single value equal to the maximum ampere setpoint of the EMS shall be permitted for one or more of the following:

- (1) For calculating the connected load per 220.70
- (2) For the maximum source current permitted by EMS control

**750.30(C)(2) System Malfunction.**

The EMS shall use monitoring and controls to automatically cease current flow upon malfunction of the EMS.

**750.30(C)(3) Settings.**

Adjustable settings shall be permitted if access to the settings is accomplished by at least one of the following:

- (1) Located behind removable and sealable covers over the adjustment means
- (2) Located behind a cover or door that requires the use of a tool to open
- (3) Located behind locked doors accessible only to qualified personnel
- (4) Password protected with password accessible only to qualified personnel
- (5) Software that has password protected access to the adjusting means accessible to qualified personnel only

**750.30(C)(4) Marking.**

The equipment that supplies the branch circuit, feeder, or service shall be field marked with the following information:

- (1) Maximum current setting
- (2) Date of calculation and setting
- (3) Identification of loads and sources associated with the current limiting feature
- (4) The following or equivalent wording: "The setting for the EMS current limiting feature shall not be bypassed"

The markings shall meet the requirements in 110.21(B) and shall be located such that they are clearly visible to qualified persons before examination, adjustment, servicing, or maintenance of the equipment.

**750.50 Directory.**

Where an energy management system is employed to control electrical power through the use of a remote means, a directory identifying the controlled device(s) and circuit(s) shall be posted on the enclosure of the controller, disconnect, or branch-circuit overcurrent device.

**Effective date:** This ordinance shall be in effect immediately upon adoption.

Approved and adopted this 10th of April 2025



**TONI PRECKWINKLE**, President  
Cook County Board of Commissioners

(S E A L)

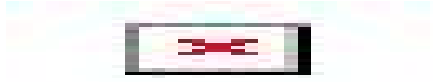

Attest:

**MONICA M. GORDON**, County Clerk