

STATE OF GEORGIA  
CITY OF RINCON

ORDINANCE

**AN ORDINANCE BY THE MAYOR AND CITY COUNCIL FOR THE CITY OF RINCON REPEALING THE CODE OF THE CITY OF RINCON, GEORGIA AT CHAPTER 90 (ZONING AND GROWTH MANAGEMENT), ARTICLE III (GENERAL PROVISIONS), SECTION 90-62 (ACCESS TO PUBLIC STREET REQUIRED), SECTION 90-65 (OFF-STREET PARKING AND UNLOADING), SECTION 90-66 (OBSTRUCTION TO VISION AT STREET INTERSECTIONS), SECTION 90-70 (DESIGNATED ON STREET PARKING), SECTION 90-90 (STREETS), SECTION 90-91 (SERVICE OR CURBSIDE LANES), SECTION 90-97 (TRESPASS BY CONSTRUCTION ON PUBLIC RIGHT-OF-WAY) AND THE ENTIRETY OF ARTICLE IV (SIGN REGULATIONS); TO BE REPLACED WITH CHAPTER 90 (ZONING AND GROWTH MANAGEMENT), SECTION 90-62 (ACCESS TO PUBLIC STREET REQUIRED) THROUGH 90-90 (RESERVED); TO PROVIDE FOR NOTICE; TO PROVIDE FOR SEVERABILITY; TO PROVIDE AN EFFECTIVE DATE; TO REPEAL ALL ORDINANCES AND PARTS OF ORDINANCES IN CONFLICT HEREWITH; AND FOR OTHER PURPOSES.**

**WHEREAS**, the duly elected governing authority of the City of Rincon, Georgia is authorized by O.C.G.A. § 36-35-3 to adopt ordinances relating to its property, affairs and local government;

**WHEREAS**, the Mayor and Council have authority to amend the City's ordinances from time to time and where necessary to maintain adequate regulations, and;

**NOW THEREFORE, THE MAYOR AND COUNCIL OF THE CITY OF RINCON HEREBY ORDAINS**, in a regular meeting assembled and pursuant to lawful authority thereof, as follows:

**Sec. 90-62. - Access to public street required.**

No building shall be constructed or erected upon a lot, or parcel of land, which does not abut upon a public street, publicly approved street, or permanent easement of access to a public street. Such an easement must have a minimum width of 25 feet unless an easement of lesser width was of record prior to the adoption of this chapter.

If a subdivision consists of more than 75 lots, then two or more permanent, publicly approved entrances/exits are required.

**Sec. 90-63. - Off-street parking and unloading.**

(A) Parking Requirements.

Table 90-63.1 provides the required parking requirements per use. Parking for uses not included on the table shall be reviewed and determined by the Director of Planning and Development or designee.

Table 90.63.1

<b>Uses</b>	<b>Parking Spaces required</b>
Adult entertainment establishments	1 per 200 square feet of floor area
Adult Care Facilities and Hospitals	1 for each 2 patient beds
Amusement Facility	1 per 500 square feet of enclosed area plus 1 per 1,000 square feet of outdoor area
Athletic Club or Gymnasium	1 per 300 square feet of floor area
Automotive Repair Services	3 per service bay
Boarding House or Bed & Breakfast Inn	1 for each 2 beds
Business and Professional Offices	1 per 300 square feet floor area
Childcare Center	1 for each 10 students
Church or Place of Worship Private Club	1 for each 4 seats of maximum seating capacity in principle assembly area and 1 for each 17 classroom seats
Community Center, Cultural Facilities or Library	1 per 500 square feet of floor area
Duplex	2 for each dwelling unit
Full-service car wash	2 per every wash bay
Funeral Home	20 for each parlor
Gas Station	2 for every 4 pumps
Health Services	1 per 250 square feet of floor area
Manufactured Home	2 per dwelling unit
Manufacturing, industrial plant, laboratory, bottling plants	1 per 300 square feet of office space plus 1 per every 5,000 square feet of research or laboratory space, warehouse space, and/or manufacturing space
Mobile Home, Travel Trailer, Campgrounds, and Recreational Vehicle Parks	1 per individual site
Motel or Hotel	1 for each guest room plus 1 per 300 square feet of administrative area plus 1 per 300 square feet of event space
Motorized Equipment and Machinery Sales	1 for each 2,500 square feet of lot area
Movie Theater	1 for every 4 seats
Multi-unit Attached—Apartments	1.5 per dwelling unit
Private club or event center	1 per 300 square feet of floor area
Public Park	1 per 1,000 square feet of activity area
Public or Private Schools	1 per classroom plus 1 for each 300 square feet of administrative area
Single-family	2 per dwelling unit

Restaurants and breweries	1 per 125 square feet of floor area
Retail and Personal Services (including Shopping Centers)	1 per 300 square feet floor area
Self-Service Laundry	1 per every 5 laundry machines
Townhouse	2 for each dwelling unit plus amenity and guest parking of 1 additional space per every 5 units.
Vehicle Sales	1 for each 400 square feet floor area
Wholesale Trading and Warehousing	1 for 1,000 square feet, plus 1 for each 300 square feet of retail sales or service

(B) Parking Standards Single-Family and Two-Family.

Off-street parking spaces shall be provided on every lot on which any of the following uses are hereby established. Driveways must serve only one lot. Common driveways are not permitted to serve single-family and two-family units. Off-street parking spaces shall include adequate maneuvering areas and shall be provided with vehicular access to a street or lane. All parking spaces shall be:

- (1) Made of an asphalt, concrete or other city approved product;
- (2) A minimum of nine feet in width and 18 feet in length; and
- (3) Equal in number to at least the minimum requirements for the specific use set forth in Table 90.63.1.
- (4) Recreational vehicles. Recreational vehicles shall be parked in the side or rear of the primary structure and shall not protrude past the front of the primary structure.
- (5) Residential curb cuts. Paving of driveways are required for all properties as they are developed, including those that front exclusively on unpaved roads. Property owners shall pave all driveways from the right-of-way line to the edge of the existing paved streets.
  - a. No more than two combined entrances and exits shall be allowed for any parcel of property, having a frontage less than 200 feet on any one street. Additional entrances or exits for parcels having a frontage in excess of 200 feet may be permitted at the rate of one entrance/exit for each additional 200 feet of frontage.
  - b. The distance between any two curb cuts on the same side of the street shall be more than ten feet on local roads, 25 feet on collector, and 35 feet on arterial.
  - c. The width of any driveway shall not exceed 24 feet at the right-of-way line and 24 feet measured at the edge of pavement.
  - d. The property owner may submit to the Planning and Development Department a request to install a shorter paved area for the driveway due to extreme circumstances.

(C) Parking Standards Multi-family residential districts.

Additional parking shall be required for clubhouse and other non-residential uses. A parking plan shall be included with the site plan application. The storage of campers, boats, or other

recreational equipment shall not be permitted unless a common parking area designed for these features is included with the site plan application.

(1) Curb cuts for multi-family residential dwellings shall meet the following requirements:

- a. No more than two combined entrances and exits shall be allowed for any parcel where the frontage is less than 300 feet on any one street. On parcels with less than 150 feet of frontage, only one combined entrance and exit shall be allowed (two one-way driveways shall be allowed in lieu of the one two-way). Additional entrances or exits for parcels of property having a frontage in excess of 300 feet may be permitted at the rate of one entrance/exit for each additional 200 feet of frontage;
- b. All driveways shall be constructed so as to be at least ten feet from the property line; and,
- c. Maximum width of any driveway shall not exceed 35 feet measured at the end of the radii (minimum 12½-foot radius).
- d. Minimum length of any driveway shall be at least 25 feet from the rear edge of sidewalk, or property line if a sidewalk is not required

(2) All parking spaces shall be:

- a. Made of asphalt, concrete or other City approved product;
- b. A minimum of nine feet in width and 18 feet in length; and
- c. Equal in number to at least the minimum requirements for the specific use set forth in Table 90-63.1.
- d. All parking spaces must be clearly marked by a white painted stripe no less than 4 inches wide running the length of each of the sides of the space, or by curbing, or by another acceptable method to clearly designate the space.

(3) All surface parking lots shall have the following minimum lighting requirements:

a. Illumination shall provide an average maintained illumination of not less than one footcandle equal to one lumen per square foot at grade level, and shall be well distributed in the pavement areas; however, at no point shall illumination be less than an one-half footcandle of light measured at grade level. The maximum to minimum Footcandle level shall not exceed a 12 to one (12:1) ratio and the average to minimum footcandle level shall not exceed a four to one (4:1) ratio.

b. All parking lot lights shall be dark sky compliant and shall be horizontal to the ground.

c. Where applicable, public street lighting may be utilized to either partially or totally fulfill the lighting requirements; however, where street lighting is removed it should be the responsibility of the entity to independently provide these required levels of illumination.

d. All outdoor lighting shall be no greater than 15 feet above grade for non cut-off lights and 35 feet above grade for full cut-off lights.

(D) Parking Standards Commercial districts.

Off-street parking spaces shall be provided on every lot per Table 90-63.1. Such spaces shall include adequate maneuvering areas and shall be provided with vehicular access to a street or lane. Parking shall be no closer than ten feet to the street, road, or right-of-way. The parking plan shall be submitted with the site plan application.

(1) Commercial delivery to businesses.

- a. All deliveries to businesses shall be made in appropriate designated and approved delivery areas.
- b. No area designated or used for deliveries may extend or result in the extension of vehicles onto a public right-of-way.

(2) Curb cuts for commercial land uses shall meet the following requirements:

- a. No more than two combined entrances and exits shall be allowed for any parcel where the frontage is less than 300 feet on any one street. On parcels with less than 150 feet of frontage, only one combined entrance and exit shall be allowed (two one-way driveways shall be allowed in lieu of the one two-way). Additional entrances or exits for parcels of property having a frontage in excess of 300 feet may be permitted at the rate of one entrance/exit for each additional 200 feet of frontage;
- b. All driveways shall be constructed so as to be at least 12 feet from any side of the property line and building; and,
- c. Maximum width of any driveway shall not exceed 35 feet measured at the end of the radii (minimum 12½-foot radius);

(3) All parking spaces shall be:

- a. Made of a asphalt, concrete or other City approved product;
- b. A minimum of nine feet in width and 18 feet in length; and
- c. Equal in number to at least the minimum requirements for the specific use set forth in Table 90-63.1.
- d. All parking spaces must be clearly marked by a white painted stripe no less than 4 inches wide running the length of each of the sides of the space, or by curbing, or by another acceptable method to clearly designate the space.

(4) All surface parking lots shall have the following minimum lighting requirements:

- a. Illumination shall provide an average maintained illumination of not less than one footcandle equal to one lumen per square foot at grade level and shall be well distributed in the pavement areas; however, at no point shall illumination be less than one-half footcandle of light measured at grade level. The maximum to minimum Footcandle level shall not exceed a 12 to one (12:1) ratio and the average to minimum footcandle level shall not exceed a four to one (4:1) ratio.
- b. All parking lot lights shall be dark sky compliant and shall be horizontal to the ground.
- c. Where applicable, public street lighting may be utilized to either partially or totally fulfill the lighting requirements; however, where street lighting is removed it should be the responsibility of the entity to independently provide these required levels of illumination.

d. All outdoor lighting shall be no greater than 15 feet above grade for non cut-off lights and 35 feet above grade for full cut-off lights.

(E) Parking Standards Industrial Districts.

(1) No more than two combined entrances and exits shall be allowed for any parcel where the frontage is less than 300 feet on any one street. On parcels with less than 150 feet of frontage, only one combined entrance and exit shall be allowed (two one-way driveways shall be allowed in lieu of the one two-way). Additional entrances or exits for parcels of property having a frontage in excess of 300 feet may be permitted at the rate of one entrance/exit for each additional 200 feet of frontage;

(2) All driveways shall be constructed so as to be at least 12 feet from any side of the property line and building; and,

(3) Maximum width of any driveway shall not exceed 35 feet measured at the end of the radii (minimum 12-foot radius).

(4) All parking spaces shall be:

- a. Made of a asphalt, concrete or other City approved product;
- b. A minimum width of nine feet in width and 18 feet in length; and
- c. Equal in number to at least the minimum requirements for the specific use set forth in Table 90.63.1 and:
- d. All parking spaces must be clearly marked by a white painted stripe no less than 4 inches wide running the length of each of the sides of the space, or by curbing, or by another acceptable method to clearly designate the space.

(5) All surface parking lots shall have the following minimum lighting requirements:

a. Illumination shall provide an average maintained illumination of not less than one footcandle equal to one lumen per square foot at grade level and shall be well distributed in the pavement areas; however, at no point shall illumination be less than one-half footcandle of light measured at grade level. The maximum to minimum Footcandle level shall not exceed a 12 to one (12:1) ratio and the average to minimum footcandle level shall not exceed a four to one (4:1) ratio.

b. All parking lot lights shall be dark sky compliant and shall be horizontal to the ground.

c. Where applicable, public street lighting may be utilized to either partially or totally fulfill the lighting requirements; however, where street lighting is removed it should be the responsibility of the entity to independently provide these required levels of illumination.

d. All outdoor lighting shall be no greater than 15 feet above grade for non cut-off lights and 35 feet above grade for full cut-off lights.

(6) Commercial delivery to industrially zoned establishments:

- a. All deliveries shall be made in appropriate designated and approved delivery areas.

- b. No area designated or used for deliveries may extend or result in the extension of vehicles onto a public right-of-way.
- (F) All off-street parking spaces shall meet all City of Rincon and other applicable construction standards.

**Sec. 90-64. - Street intersection sight triangles.**

**(A) Sight triangle standards**

Intersections shall be designed with adequate corner sight triangles as depicted in Figure 90-64.1. Where necessary, back slopes shall be flattened and horizontal or vertical curves lengthened to provide the minimum required sight triangle.

The minimum intersection sight triangle requirement may be calculated using AASHTO "Policy on Geometric Design of Highways and Streets," chapter 9 (Intersections), latest edition. Intersection sight triangle is determined with an assumed height of driver's eye of 3.5 feet and an assumed height of object of 3.5 feet when measuring in the vertical plane. When measuring in the horizontal plane, the intersection sight triangle is determined with an assumed driver's eye location from a point four feet offset from the centerline and 15 feet from the edge of closest travel lane to a point along the centerline of the closest oncoming travel lane. When measuring in either plane, the line of sight must remain within the proposed standard dedicated right-of-way:

Figure 90-64.1

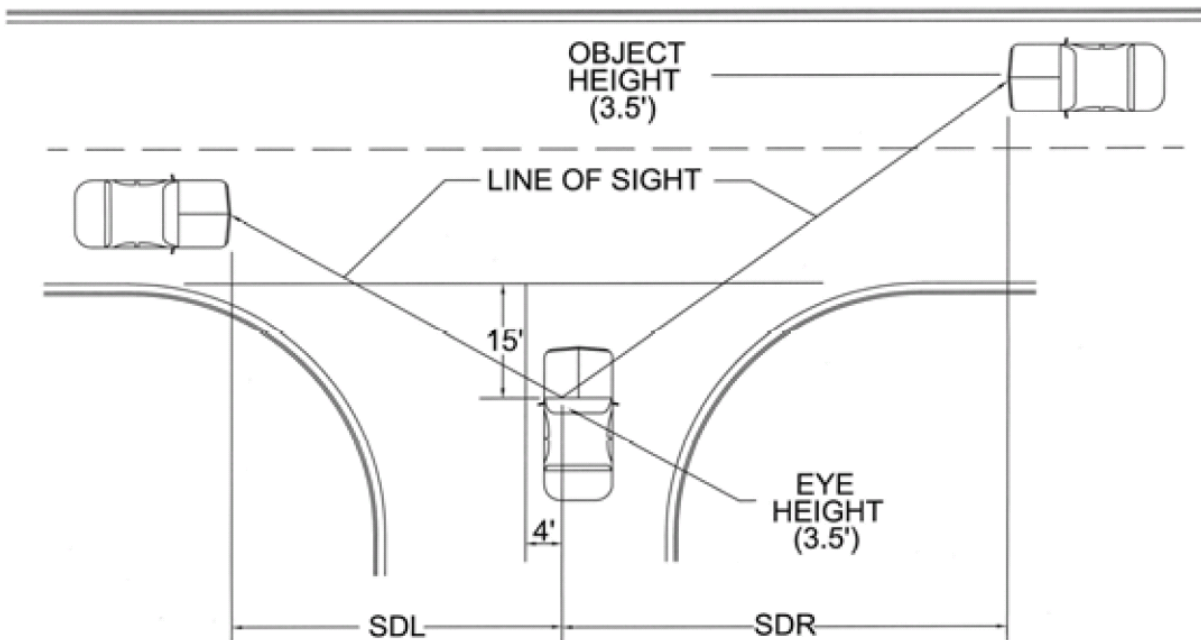

**(B) Obstructing visibility at intersections.** On any corner lot, within an area formed by the lot lines on the street sides of such lot and a line joining points on such lot lines located at a distance of 20 feet from the point of their intersection, the following shall apply:

- a. There shall be no fence or wall or hedge higher than three feet.

b. There shall be no obstruction to vision, other than a post or column or tree (except standards erected by city) exceeding one foot in greatest cross-sectional dimension, between a height of three feet and a height of 15 feet above the established grade of either of the intersecting streets.

c. The City Manager or designee may require additional restrictions based on the horizontal or vertical curvature of the roadway or any unique features of the intersection.

**Sec. 90-65. - Designated on-street parking.**

No designated on-street parking space may be proposed, established or permitted on any new public or private roadway or street depicted on any preliminary or final land development plan, or on any preliminary or final land subdivision plat referencing a major subdivision, or on any final land subdivision plat referencing a bona fide minor subdivision, nor shall any be authorized by any official City land development permit issued by the Planning and Development Department, unless formally approved by the Mayor and Council.

**Sec. 90-66. - Streets.**

Streets shall be two-way and a minimum width of 20 feet of pavement for a local street and 32 feet of pavement for a collector street. On-street parking shall be prohibited. All manufactured home spaces shall abut upon an interior drive which shall have unobstructed access to a public street or highway.

(A) Vehicles, including but not limited to landscaping trailers or moving trucks, that temporarily park on public streets must be sufficiently marked with traffic cones to indicate their presence in the right-of-way. This provision is not applicable to daily delivery vehicles.

**Sec. 90-67. - Service or curbside lanes.**

No service or curbside lanes may be designated for vehicle parking spaces; all such lanes must be restricted only for loading and unloading of passengers and goods, and for the temporary accommodation of disabled vehicles.

**Sec. 90-68. - Trespass by construction on public right-of-way.**

No public or private building or structure, advertising sign, road or street, bridge, water supply system, sanitary sewerage system, stormwater drainage system, pole, tower, sign or other mobile or immobile object shall be constructed or placed on any public way or public right-of-way, or constructed or placed to overhang any public right-of-way, nor to obstruct or restrict access to or from any public right-of-way, except in full conformance with all the terms, conditions, rules, standards and requirements of this Chapter and this chapter.

(A) Only an authorized government unit or agency, or authorized contractor or agent of such unit or agency, may install traffic control, hazard warning, public directory or public information signs, symbols, barricades or devices, or any sign-supporting structure, on any public right-of-way or roadway.

(B) No advertising sign, or other private purpose sign, or any private purpose sign-supporting structure, shall be constructed or located on, or overhang, any public right-of-way or roadway.

(C) Street lights, street name signs, traffic control, hazard warning, public directory or public information signs, symbols, barricades or devices constructed or installed by an authorized government unit or agency, or by an authorized contractor or agent of such unit or agency, and necessary utility service poles installed by any public or private utility company shall be exempt from this restriction.

**Sec. 90-69-90-74. - Reserved.**

**Sec. 90-75. - Purpose of sign regulations.**

The purposes of this chapter are to:

- (a) Regulate the size, illumination, and other characteristics of all types of signs and sign structures;
- (b) Encourage adequate identification of businesses and other uses within the City for general public convenience; and
- (c) Promote traffic safety by prohibiting an excessive number of signs, or signs of excessive size which may confuse or distract motorists, and by prohibiting signs which obstruct sight distance at roadway intersections or along public rights-of-way.

**Sec. 90-76. - General and special provisions.**

No sign or sign structure shall be used, reused, altered, remodeled, constructed, relocated or demolished, except in compliance with all the provisions of this chapter.

- (1) *Encroachment on or over public rights-of-way prohibited.* Only an authorized federal, state, county or City government unit or agency, or authorized contractor or agent of such unit or agency, may install traffic control, hazard warning, public directory or public information signs, symbols, barricades or devices, or any sign-supporting structure, on or overhanging any public right-of-way or roadway within their respective jurisdictions.
  - (a) No private purpose sign or any sign-supporting structure, shall be constructed or located on, or overhang, any public right-of-way or roadway, unless such structure or sign is specifically permitted by the responsible government unit or agency.
- (2) *Vision obstructions prohibited.* No sign or sign supporting structure shall be located or constructed where such sign or structure obstructs the visibility of traffic, traffic control or directional signs or signals, when viewed from any public roadway or driveway.
- (3) *Vertical and horizontal clearance required.* No sign constructed or located on private property at any public driveway, where vehicles pass under such sign, shall be lower than 16.0 linear feet measured vertically from the driveway crown to the bottom of the sign.
- (4) *Setback required.* All signs constructed or located on private property shall be set back not less than five linear feet from all public right-of-way lines and property lines.
- (5) *Only one primary sign per lot.* Only one primary sign shall be permitted on any individual lot.
- (6) *Wind-resistant construction required.* All plans for all permanent signs and sign structures shall meet wind loading requirements for this area. The plan must incorporate design and construction features adequate to prevent sign overturning,

collapse or disintegration from any wind pressure equivalent to current hurricane wind load for this area at the time of application.

- (7) *Sign measurement.* Sign display areas shall be measured by taking the area of the sign, letters, names, pictures, logos or symbols to determine total sign display area.
- (8) *Visibility of neighboring signs required.* No sign shall be constructed or located to obscure the visibility of another sign located on a neighboring or adjacent lot.
- (9) *Temporary signs.* No temporary sign shall be permitted on public property, except public information or traffic control signs erected and maintained by an authorized governmental unit or agency and as listed below:
  - (a) A maximum limit of one permitted temporary sign, including a banner sign, per lot for a maximum time limit of 45 days shall be allowed on private property. A sign permit is required for a temporary sign.
  - (b) Only one realtor's sign per lot is allowed. A sign permit is not required for a realtor sign.
  - (c) Yard sale signs shall be allowed not more than three days prior to the sale and removed not more than two days after the sale. A sign permit is not required for a yard sale sign.
  - (e) A construction site may have more than one authorized temporary sign per approval of the City Planning or designee.
  - (f) Required legal advertising shall be permitted and shall be removed not more than two days after the event in which the notice advertised has occurred. No permit shall be required.
- (10) *Removal of out-of-service permanent signs.* All out-of-service permanent signs shall be removed within 180 days from the date the establishment relating to the sign was terminated, relocated, or discontinued. In lieu of removing the sign, an opaque cover can be placed over the sign.
- (11) *Sign maintenance required.* All permanent signs, sign faces, sign posts, and all elements of all permanent sign supporting assemblies, shall be maintained in a safe condition and in good working order.
- (12) *Display of flags.* Any display of a flag may be allowable, but such flags must comply with all setbacks, horizontal and vertical clearance, and other relevant provisions of this chapter and this chapter. Nothing in this section is intended to bar or to limit the lawful display of any official flag.
- (13) All residences and businesses shall provide a conspicuous address. Businesses may also have their addresses painted on the curb in addition to on a fixed location.
- (14) *Billboards.* No billboard shall be erected except in compliance with the regulations listed below:
  - (a) All illuminated billboards shall use base-mounted lights. The light source must not be visible from a vehicle or residence. No additional lighting shall be allowed.
  - (b) All billboards shall be a minimum of ten (10) feet above grade and a maximum of thirty (30) feet above grade.
  - (c) Extrusions beyond the face of the billboard, excluding aprons, are prohibited.

- (d) Only one billboard shall be allowed to face the same direction per location. This allows back-to-back or V formation billboards but prohibits two billboards facing the same direction.  
Billboard location shall be no less than 500 feet from the nearest billboard measuring from the nearest point.
- (e) No more than three (3) billboards shall be permitted per mile when such billboards are located on the same side of the road.
- (f) Billboard structures shall be no less than ten (10) feet from any property line.
- (g) All billboards must also comply with all aspects of the Georgia Outdoor Advertising Code.

**Sec. 90-77. - Sign permits and fees required.**

A "sign permit" shall be required for the construction and location of all signs and sign structures, except signs exempted from the requirements of this chapter.

- (A) *Sign permit applications.* Each application for a sign permit submitted to the Department of Planning and Development shall be accompanied by all necessary construction plans, exhibits, location(s) and other information as required and shall include all required fees.
- (B) *Required plans, exhibits information and fees.* The following plans shall accompany each application for sign permit:
  - (a) Street address of each proposed sign location, survey sketch or other dimensioned drawing of each proposed sign location, total lot frontage dimensions, setback distances from nearest public rights-of-way and location of nearest public driveways;
  - (b) Dimensioned drawings showing all existing and proposed building signs and freestanding signs, plans for all signs showing all sign face and sign support dimensions, total areas of all sign faces expressed in linear feet and square feet, type of proposed construction materials, illumination details, colors, and all other relevant information; and
- (C) *Sign permit fees.* The administrative and inspection fees shall be paid with each application for a sign permit. The list of fees shall be available in the Department of Planning and Development.

**Sec. 90-78. - Nonconforming signs.**

Any existing sign which did not conform to the terms, conditions, rules, regulations or provisions of this chapter, on the day the ordinance was adopted, shall be defined as substandard and nonconforming.

- (A) *Disposition of nonconforming signs.* Any sign, or sign structure lawfully existing at the time of adoption of this chapter, may continue to be used, the premises may be rented or leased, and title may be transferred or conveyed by sale, by device or by other lawful means.
  - (a) Any existing lawful sign may be maintained and repaired if such activity fully conforms to all City-adopted Building, Housing, Fire, Electrical, Mechanical and Plumbing Codes, and all other county, state or federal laws regulating related subject matter; and
  - (b) No land development permit, occupancy permit or other authorization shall be issued which will have the effect of permitting the reconstruction of, or expansion

of, or enlargement of, any nonconforming sign that existed at the time of adoption of this chapter or that was unlawfully created after this chapter was adopted, unless all work sanctioned by the Permit will bring the sign into conformance with ordinance requirements.

#### **Sec. 90-79. - Administrative remedies for unsafe signs.**

The owner of any sign or sign structure which has been officially determined to be in violation of the provisions of this chapter, shall be cited with an official notice from the City.

- (A) *Administrative corrective actions.* If any sign owner fails to correct the sign conditions cited in any violation notice within 5 business days, the Planning and Development Department staff shall initiate all actions necessary to correct the cited conditions and to bring the sign into conformance with this chapter.
- (B) *Administrative costs.* All costs of all administrative corrective actions necessary to bring any sign into conformance with this chapter, shall be charged to violator. If such fees are not paid within 90 days, a lien or other appropriate legal action shall be initiated by the City.
- (C) *Immediate removal permitted.* Any sign or sign structure that is officially determined to be unsafe or insecure or a public hazard, and which constitutes an immediate peril to persons or property, may be summarily removed without notice by the Planning and Development Department staff, or at their direction, if the sign owner cannot be readily notified of such condition or necessary action.

#### **Sec. 90-80. - Allowable Signs.**

See Table 1.

#### **Sec. 90-81. - Sign types and dimensions.**

Specified types of signs, sign elements or other features designated as allowed or prohibited in the various districts, are listed on the following Table 2.

#### **Sec. 90-82. - List of prohibited signs.**

Various types of prohibited signs, sign elements or other sign features are listed on the following:

- (1) Any sign with a display area more than 100 square feet per sign face.
- (2) Any sign with flashing, animated, moving, revolving or rotating sign faces or beams of light (not including signs conveying time or temperature information to the public).
- (3) Any sign illumination from any internal or external light source that creates any hazard to motorists, or which constitutes a public or private nuisance to occupants of any neighboring building.
- (4) Any private purpose sign attached to, constructed on, or located on any public roadway or right-of-way, roadway curb or shoulder, fire hydrant, utility pole, public fence, or on any tree or plant, barricade, or signpost located within any public right-of-way (except building street address numbers painted on curbs and resident or occupant identity signs on mailboxes).
- (5) All flags, feather signs, pennants, spinners, streamers, balloons that are tethered more than ten feet above the ground, or other wind-powered advertising devices. (See Sec. 90-76, Subsection (2) of this article.)

- (6) Any roof-mounted sign (but not including signs mounted on "mansard-type" roofs as fascia signs).
- (7) Any mobile, trailer-mounted, portable, folding, or other moveable or re-locatable sign.
- (8) Any private purpose sign containing any word(s) or symbol(s) similar to traffic control signs, including but not limited to the words "Stop", "Go", "Slow", and "Danger" (but not including any sign intended for traffic safety, hazard warning or human protection purposes on public or private property).

**TABLE 1: ALLOWABLE SIGNS**

Permitted Signage				
SIGN FUNCTION OR PURPOSE	Agriculture AR-1 & AR-2 Districts	Residential R-1, R-2, R-3, R-4 & R-5 Districts	PUD OC, B-1 & B-2 Districts	Industrial L-1 & H-1 Districts
<b>Permanent Signs</b>				
Primary Wall Sign	P	P	P	P
Monument Sign	P	P	P	P
Directory, Informational & Directional	P	P	P	P
Billboards			P	P
<b>Temporary Signs</b>				
Construction Sign	P	P	P	P
Banner Sign	P	P	P	P
Real Estate Sign	P	P	P	P
Temporary Sign	P	P	P	P
P=Permitted, Blank = Prohibited				

**TABLE 2: LIST OF SIGN TYPES AND DIMENSIONS**

Sign standards when permitted in district.					
TYPES OF SIGNS	Agriculture AR-1 & AR-2 Districts	Residential R-1, R-2, & R-3, R-4 & R-5 Districts	PUD, OC, B-1 & B-2 Districts	Industrial L-1 & H-1 Districts	Additional Standards
Address Sign	Length: 5 LF Area: 1 SF	Length: 5 LF Area: 1 SF	Length: 5 LF Area: 1 SF	Length: 5 LF Area: 1 SF	
Monument Sign	Length: 8 LF Area: 40 SF Maximum height: 5 feet measured from top of sign to bottom, 12 feet measured from grade to top of sign	Length: 8 LF Area: 40 SF Maximum height: 5 feet measured from top of sign to bottom of sign	Length: 20 LF Area: 100 SF Maximum height: 5 feet measured from top of sign to bottom, 20 feet measured from grade to top of sign	Length: 20 LF Area: 100 SF Maximum height: 5 feet measured from top of sign to bottom, 20 feet measured from grade to top of sign	
Mansard sign	Length: 6 LF Area: 32 SF	Length: 6 LF Area: 16 SF	20 LF 100 SF	20 LF 100 SF	Maximum Height: 5 feet measured from top of sign to bottom.

Hanging or Projecting (Under-canopy or cantilevered)	Length: 6 LF Area: 32 SF	Length: 6 LF Area: 32 SF	Length: 6 LF Area: 32	Length: 6 LF Area: 32	Minimum clearance from grade: 8 feet
Marquee (Moveable letters)	Length: 6 SF Area: 32 SF	Length: 6 SF Area: 32 SF	Length: 6 SF Area: 32 SF	Length: 6 SF Area: 32 SF	
Awning or Canopy	Length: 6 LF Area: 32 SF	Length: 6 LF Area: 32 SF	Length: 6 LF Area: 32 SF	Length: 6 LF Area: 32 SF	
Banner	Length: 6 LF Area: 32 SF	Length: 6 LF Area: 32 SF	Length: 6 LF Area: 32 SF	Length: 6 LF Area: 32 SF	
Other Temporarily	Length: 6LF Area: 16 SF  Maximum height: 5 feet measured from top of sign to bottom of sign	Length: 6 LF Area: 16 SF  Maximum height: 5 feet measured from top of sign to bottom of sign	Length: 6 LF Area: 16 SF  Maximum height: 5 feet measured from top of sign to bottom of sign	Length: 6 LF Area: 16 SF  Maximum height: 5 feet measured from top of sign to bottom of sign	
Billboard	20 LF 100 SF		20 LF 100 SF	20 LF 100 SF	

**Explanation of Symbols:** LF = Linear Feet SF = Square Feet

Maximum Height—Measured from ground/grade to top of sign.

**Secs. 90-83—90-90. - Reserved.**

**Severability.** If any section, clause, sentence or phrase of this ordinance is held to be invalid or unconstitutional by any court of competent jurisdiction, then said holding shall in no way effect the validity of the remaining portions of this ordinance.

**Effective Date.** This ordinance shall become effective immediately upon its adoption by the City Council.

**Repeal.** All ordinances and parts of ordinances in conflict with this ordinance are hereby repealed.

SO ORDAINED this 12 day of August, 2024.