

ORDINANCE

AN ORDINANCE OF THE COMMISSION OF  
KNOX COUNTY, TENNESSEE, TO REPEAL  
AND REPLACE THE 2012 EDITIONS OF  
CERTAIN BUILDING, SAFETY, AND OTHER  
STANDARDIZED CODES WITH THE 2018  
EDITIONS OF SAME AND TO REPEAL  
KNOX COUNTY CODE, CHAPTER 26,  
ARTICLE III. NOISE. (Ord. No. O-12-9-101,  
adopted 10-22-12, Ord. No. O-90-10-103,  
adopted 11-19-90, Ord. No. O-92-11-102,  
adopted 1-25-93, Ord. No. O-93-11-103,  
adopted 12-20-93, Ord. No. O-96-10-102,  
adopted 11-25-96, and Ord. No. O-14-5-102,  
adopted 6-23-14).

ORDINANCE: O-18-10-101

REQUESTED BY: CODE ADMINISTRATION

PREPARED BY: KNOX COUNTY LAW  
DIRECTOR'S OFFICE

APPROVED AS TO FORM  
AND CORRECTNESS:

*Richard B. Armstrong Jr.*  
\_\_\_\_\_  
DIRECTOR OF LAW

APPROVED 1<sup>ST</sup> READING: October 22, 2018  
DATE

APPROVED 2<sup>ND</sup> READING: November 19, 2018  
DATE

APPROVED EMERGENCY: \_\_\_\_\_  
(YES) (NO)

VETOED: \_\_\_\_\_  
DATE

VETO  
OVERRIDE: \_\_\_\_\_  
DATE

MINUTE  
BOOK \_\_\_\_\_ PAGE \_\_\_\_\_

**WHEREAS, it is the policy of Knox County to adopt codes and regulations as are necessary for the preservation and enhancement of the health, safety, and welfare of the citizens of Knox County; and**

**WHEREAS, Knox County previously adopted building, fire, property maintenance, and other associated standardized codes published by the International Code Council, Inc., which are now outdated; and**

**WHEREAS, Knox County desires to repeal and replace the 2012 editions of these codes with the 2018 editions of same and to repeal Knox County Code, Chapter 26, Article III entitled "Noise" as the provisions under Chapter 26 have been incorporated into the 2018 International Property Maintenance Code; and**

**WHEREAS, the most current code provisions and editions of the codes to be adopted herein have been reviewed by Knox County code officials, and, in consultation with Knox County contractors, builders, and designers, suggested amendments to these codes have been incorporated herein.**

**NOW THEREFORE BE IT ORDAINED BY THE COMMISSION OF KNOX COUNTY AS FOLLOWS:**

**SECTION 1. Knox County Code Chapter 10, Article I, entitled "In General", is hereby repealed and replaced with a new Article I for the purpose of resolving the effects of conflicts between codes within Knox County, which article shall read as follows:**

**ARTICLE I. IN GENERAL**

**Section 10-1. Effect of conflicts between codes.**

**If the provisions of any of the codes contained in this chapter conflict with the fire prevention chapter, the more stringent provisions shall control; provided however, that, if there are conflicts between the 2018 International Building Code and the 2018 Life Safety Code, NFPA 101, and the code officials cannot reasonably determine which provision is more stringent, the provisions of the 2018 International Building Code shall control. If there is a conflict between the referenced code sections in both NFPA 101 and the IFC the section governing referenced standards in NFPA 101 shall apply.**

**SECTION 2. Knox County Code Chapter 10, Article II, entitled "2012 International Building Code (IBC)", is hereby repealed and replaced with a new Article II for the purpose of regulating the construction, alteration, movement, enlargement, replacement, repair, equipment, use and occupancy, location, maintenance, removal, and demolition of every building or structure or any appurtenances connected or attached to such buildings or structures within Knox County, which article shall read as follows:**

**ARTICLE II. 2018 INTERNATIONAL BUILDING CODE (IBC)**

**Section 10-31. Adopted.**

**The county hereby adopts the 2018 edition of the International Building Code, published by the International Code Council, Inc., by reference, as if set out at length in this section, with amendments set out in this article.**

**Section 10-32. Amendments.**

The code adopted by this article is amended as provided in this section (the section identifiers contained within these amendments conform to the 2018 International Building Code): (Insert Exhibit I)

**Section 10-33. Locations of Code.**

- a. A copy of the 2018 edition of the International Building Code, published by the International Code Council, Inc., shall be obtained and retained as a public record by the Knox County Department of Code Administration.
- b. If any person is cited in violation of this article, a notation shall be included in such citation identifying with specificity where a copy of such code is located and the hours during which such person has the opportunity to read or inspect such code or document.

**SECTION 3. Knox County Code, Chapter 10, Article III entitled “2012 International Residential Code”, is hereby repealed and replaced with a new Article III for the purpose of regulating the construction, alteration, movement, enlargement, replacement, repair, equipment, use and occupancy, location, removal and demolition of detached one- and two-family dwellings and townhouses not more than three stories above-grade in height with a separate means of egress and their accessory structures within Knox County, which article shall read as follows:**

**ARTICLE III. 2018 INTERNATIONAL RESIDENTIAL CODE (IRC)**

**Section 10-56. Adopted.**

The county hereby adopts the 2018 edition of the International Residential Code, published by the International Code Council, Inc., by reference, as if set out at length in this section, with the amendments set out in this article.

**Section 10-57. Amendments.**

The code adopted by this article is amended as provided in this section (the section identifiers contained within these amendments conform to the 2018 International Residential Code): (Insert Exhibit II)

**Section 10-58. Location of Code**

- a. A copy of the 2018 edition of the International Residential Code, published by the International Code Council, Inc., shall be obtained and retained as a public record by the Knox County Department of Code Administration.
- b. If any person is cited in violation of this article, a notation shall be included in such citation identifying with specificity where a copy of such code is located and the hours during which such person has the opportunity to read or inspect such code or document.

**SECTION 4. Knox County Code Chapter 10, Article IV entitled "2012 International Fuel Gas Code", is hereby repealed and replaced with a new Article IV for the purpose of regulating the installation of fuel gas piping systems, fuel gas utilization equipment, gaseous hydrogen systems and related accessories within Knox County, which article shall read as follows:**

**ARTICLE IV. 2018 INTERNATIONAL FUEL GAS CODE (IFGC)**

**Section 10-76. Adopted.**

**The county hereby adopts the 2018 edition of the International Fuel Gas Code, published by the International Code Council, Inc., by reference, as if set out at length in this section, with the amendments set out in this article.**

**Section 10-77. Amendments.**

**The code adopted by this article is amended as provided in this section (the section identifiers contained within these amendments conform to the 2018 International Fuel Gas Code): (Insert Exhibit III)**

**Section 10-78. Location of Code.**

- a. A copy of the 2018 edition of the International Fuel Gas Code, published by the International Code Council, Inc., shall be obtained and retained as a public record by the Knox County Department of Code Administration.**
- b. If any person is cited in violation of this article, a notation shall be included in such citation identifying with specificity where a copy of such code is located and the hours during which such person has the opportunity to read or inspect such code or document.**

**SECTION 5. Knox County Code Chapter 10, Article V entitled "2012 International Property Maintenance Code", is hereby repealed and replaced with a new Article V for the purpose of establishing minimum maintenance standards for basic equipment, light, ventilation, heating, sanitation and fire safety and regulations for lot cleanliness, abandoned and inoperable vehicles, noise, and vacant, deteriorated or blighted properties, which article shall read as follows:**

**ARTICLE V. 2018 INTERNATIONAL PROPERTY MAINTENANCE CODE (IPMC)**

**Section 10-91. Adopted.**

**The county hereby adopts the 2018 edition of the International Property Maintenance Code, published by the International Code Council, Inc., by reference, as if set out at length in this section, with the amendments set out in this article.**

**Section 10-92. Amendments.**

The code adopted by this article is amended as provided in this section (the section identifiers contained within these amendments conform to the 2018 International Property Maintenance Code): (Insert Exhibit IV)

**Section 10-93. Location of Code.**

- a. A copy of the 2018 edition of the International Property Maintenance Code, published by the International Code Council, Inc., shall be obtained and retained as a public record by the Knox County Department of Code Administration.
- b. If any person is cited in violation of this article, a notation shall be included in such citation identifying with specificity where a copy of such code is located and the hours during which such person has the opportunity to read or inspect such code or document.

**SECTION 6. Knox County Code Chapter 10, Article VI entitled "2012 International Mechanical Code", is hereby repealed and replaced with a new Article VI for the purpose of regulating the design, installation, maintenance, alteration and inspection of mechanical systems that are permanently installed and utilized to provide control of environmental conditions and related processes within buildings within Knox County, which article shall read as follows:**

**ARTICLE VI. 2018 INTERNATIONAL MECHANICAL CODE (IMC)**

**Section 10-106. Adopted.**

The county hereby adopts the 2018 edition of the International Mechanical Code, published by the International Code Council, Inc., by reference, as if set out at length in this section, with the amendments set out in this article.

**Section 10-107. Amendments.**

The code adopted by this article is amended as provided in this section (the section identifiers contained within these amendments conform to the 2018 International Mechanical Code): (Insert Exhibit V)

**Section 10-108. Location of Code.**

- a. A copy of the 2018 edition of the International Mechanical Code, published by the International Code Council, Inc., shall be obtained and retained as a public record by the Knox County Department of Code Administration.
- b. If any person is cited in violation of this article, a notation shall be included in such citation identifying with specificity where a copy of such code is located and the hours during which such person has the opportunity to read or inspect such code or document.

**SECTION 7. Knox County Code Chapter 10, Article VII entitled "2012 International Plumbing Code", is hereby repealed and replaced with a new Article VII for the purpose of regulating the erection, installation, alteration, repair, relocation, replacement, addition to, use or maintenance of plumbing systems within Knox County, which article shall read as follows:**

**ARTICLE VII. 2018 INTERNATIONAL PLUMBING CODE (IPC)**

**Section 10-136. Adopted.**

The county hereby adopts the 2018 edition of the International Plumbing Code, published by the International Code Council, Inc., by reference, as if set out at length in this section, with the amendments set out in this article.

**Section 10-137. Amendments.**

The code adopted by this article is amended as provided in this section (the section identifiers contained within these amendments conform to the 2018 International Plumbing Code): (Insert Exhibit VI)

**Section 10-138. Location of Code.**

- a. A copy of the 2018 edition of the International Plumbing Code, published by the International Code Council, Inc., shall be obtained and retained as a public record by the Knox County Department of Code Administration.
- b. If any person is cited in violation of this article, a notation shall be included in such citation identifying with specificity where a copy of such code is located and the hours during which such person has the opportunity to read or inspect such code or document.

**SECTION 8. Knox County Code, Chapter 10, Article IX, Division 2 entitled "2012 International Swimming Pool and Spa Code (ISPSC)", is hereby repealed and replaced with a new Division 2 for the purpose of regulating the design, construction or installation, repair or alteration of swimming pools, public or private, and equipment related thereto within Knox County, which division shall read as follows:**

**DIVISION 2. 2018 INTERNATIONAL SWIMMING POOL AND SPA CODE (ISPSC)**

**Section 10-216. Adopted.**

The county hereby adopts the 2018 edition of the International Swimming Pool and Spa Code, published by the International Code Council, Inc., by reference, as if set out at length in this section, with the amendments set out in this article.

**Section 10-217. Amendments.**

The code adopted by this article is amended as provided in this section (the section identifiers contained within these amendments conform to the 2018 edition of the International Swimming Pool and Spa Code: (Insert Exhibit XII)

**Section 10-218. Location of Code.**

- a. A copy of the 2018 edition of the International Swimming Pool and Spa Code, published by the International Code Council, Inc., shall be obtained and retained as a public record by the Knox County Department of Code Administration.
- b. If any person is cited in violation of this article, a notation shall be included in such citation identifying with specificity where a copy of such code is located and the hours during which such person has the opportunity to read or inspect such code or document.

**SECTION 9.** Knox County Code Chapter 10, Article X entitled "2012 International Code Council Performance Code for Buildings and Facilities (ICCPC)", is hereby repealed and replaced with a new Article X for the purpose of providing performance based requirements for regulating the construction, alteration, movement, enlargement, replacement, repair, equipment use and occupancy, location, maintenance, removal and demolition of every building or structure or any appurtenances connected or attached to such buildings or structures within Knox County, which article shall read as follows:

**ARTICLE X. 2018 INTERNATIONAL CODE COUNCIL PERFORMANCE CODE FOR BUILDINGS AND FACILITIES (ICCPC)**

**Section 10-261. Adopted.**

The county hereby adopts the 2018 edition of the International Code Council Performance Code for Buildings and Facilities , published by the International Code Council, Inc., by reference, as if set out at length in this section, with the amendments set out in this article.

**Section 10-262. Amendments.**

The code adopted by this article is amended as provided in this section (the section identifiers contained within these amendments conform to the 2018 International Code Council Performance Code for Buildings and Facilities): (Insert Exhibit IX)

**Section 10-263. Location of Code.**

- a. A copy of the 2018 edition of the International Code Council Performance Code for Buildings and Facilities, published by the International Code Council, Inc., shall be obtained and retained as a public record by the Knox County Department of Code Administration.
- b. If any person is cited in violation of this article, a notation shall be included in such citation identifying with specificity where a copy of such code is located and the hours during which such person has the opportunity to read or inspect such code or document.

**SECTION 10.** Knox County Code Chapter 10, Article XI entitled "2012 International Existing Building Code (IEBC)", is hereby repealed and replaced with a new Article XI for the purpose of regulating the repair, alteration, change in occupancy, addition and relocation of existing buildings within Knox County, which article shall read as follows:

**ARTICLE XI. 2018 INTERNATIONAL EXISTING BUILDING CODE (IEBC)**

**Section 10-281. Adopted.**

**The county hereby adopts the 2018 edition of the International Existing Building Code, published by the International Code Council, Inc., by reference, as if set out at length in this section, with the amendments set out in this article.**

**Section 10-282. Amendments.**

**The code adopted by this article is amended as provided in this section (the section identifiers contained within these amendments conform to the 2018 International Existing Building Code): (Insert Exhibit X)**

**Section 10-283. Location of Code.**

- a. A copy of the 2018 edition of the International Existing Building Code, published by the International Code Council, Inc., shall be obtained and retained as a public record by the Knox County Department of Code Administration.**
- b. If any person is cited in violation of this article, a notation shall be included in such citation identifying with specificity where a copy of such code is located and the hours during which such person has the opportunity to read or inspect such code or document.**

**SECTION 11. Knox County Code Chapter 10, Article XII entitled "2012 International Energy Conservation Code (IECC)", is hereby repealed and replaced with a new Article XII for the purpose of regulating the design and construction of buildings for the effective use and conservation of energy over the useful life of each building within Knox County, which article shall read as follows:**

**ARTICLE XII. 2018 INTERNATIONAL ENERGY CONSERVATION CODE (IECC)**

**Section 10-301. Adopted.**

**The county hereby adopts the 2018 edition of the International Energy Conservation Code, published by the International Code Council, Inc., by reference, as if set out at length in this section, with the amendments set out in this article.**

**Section 10-302. Amendments.**

**The code adopted by this article is amended as provided in this section (the section identifiers contained within these amendments conform to the 2018 International Energy Conservation Code): (Insert Exhibit XI)**

**Section 10-303. Location of Code.**

- a. A copy of the 2018 edition of the International Energy Conservation Code, published by the International Code Council, Inc., shall be obtained and retained as a public record by the Knox County Department of Code Administration.**

- b. If any person is cited in violation of this article, a notation shall be included in such citation identifying with specificity where a copy of such code is located and the hours during which such person has the opportunity to read or inspect such code or document.

**SECTION 12. Knox County Code, Chapter 10, Article XIII entitled "2012 International Green Construction Code (IGCC)" is hereby repealed and replaced with a new Article XIII for the purpose of regulating and governing the conditions and maintenance of structures, the standards for physical things and conditions essential to safeguard the environment, public health, safety and general welfare through the establishment of requirements to reduce the negative impact and increase the positive impacts of the built environment on the natural environment and building occupants, which article shall read as follows:**

**ARTICLE XIII 2018 INTERNATIONAL GREEN CONSTRUCTION CODE (IGCC)**

**Section 10-321. Adopted.**

The county hereby adopts the 2018 edition of the International Green Construction Code, published by the International Code Council, Inc., by reference, as if set out at length in this section, with the amendments set out in this article.

**Section 10-322. Amendments.**

The code adopted by this article is amended as provided in this section (the section identifiers contained within these amendments conform to the 2018 edition of the International Green Construction Code: (Insert Exhibit XIII)

**Section 10-323. Location of Code.**

- a. A copy of the 2018 edition of the International Green Construction Code, published by the International Code Council, Inc., shall be obtained and retained as a public record by the Knox County Department of Code Administration.
- b. If any person is cited in violation of this article, a notation shall be included in such citation identifying with specificity where a copy of such code is located and the hours during which such person has the opportunity to read or inspect such code or document.

**SECTION 13. Knox County Code Chapter 30, Article II entitled "2012 International Fire Code (IFC)", is hereby repealed and replaced with a new Article II for the purpose of regulating structures, processes, premises and safeguards regarding the following: fire and explosion hazards arising from the storage, handling or use of structures, materials or devices; conditions hazardous to life, property, or public welfare in the occupancy of structures or premises; fire hazards in the structures or on the premises from occupancy or operation; and matters related to the construction, extension, repair, alteration, or removal of fire suppression or alarm systems within Knox County, which article shall read as follows:**

**ARTICLE II. 2018 INTERNATIONAL FIRE CODE (IFC)**

**Section 30-31. Adopted.**

The county hereby adopts the 2018 edition of the International Fire Code, published by the International Code Council, Inc., by reference, as if set out at length in this section, with the amendments set out in this article.

**Section 30-32. Amendments.**

The code adopted by this article is amended as provided in this section (the section identifiers contained within these amendments conform to the 2018 International Fire Code): (Insert Exhibit VII)

**Section 30-33. Location of Code.**

- a. A copy of the 2018 edition of the International Fire Code, published by the International Code Council, Inc., shall be obtained and retained as a public record by the Knox County Department of Code Administration.
- b. If any person is cited in violation of this article, a notation shall be included in such citation identifying with specificity where a copy of such code is located and the hours during which such person has the opportunity to read or inspect such code or document.

**SECTION 14. Knox County Code Chapter 30, Article III entitled "2012 Life Safety Code (LSC)", is hereby repealed and replaced with a new Article III for the purpose of regulating new and existing buildings and structures regarding: Construction, protection and occupancy features necessary to minimize danger to life from the effects of fire, including smoke, heat, and toxic gases created during a fire; criteria for the design of egress facilities so as to allow prompt escape of occupants from buildings or where desirable, into safe areas within buildings; and protective features and systems, building services, operating features, maintenance activities, and other provisions to provide adequate egress time or protection for people exposed to fire while in Knox County, which article shall read as follows:**

**ARTICLE III. 2018 LIFE SAFETY CODE (LSC)**

**Section 30-56. Adopted.**

The county hereby adopts the 2018 edition of the Life Safety Code, published by the National Fire Protection Association, by reference, as if set out at length in this section, with the amendments set out in this article.

**Section 30-57. Amendments.**

The code adopted by this article is amended as provided in this section (the section identifiers contained within these amendments conform to the 2018 Life Safety Code): (Insert Exhibit VIII)

**Section 30-58. Location of Code.**

- a. A copy of the 2018 edition of the Life Safety Code, published by the National Fire Protection Association, shall be obtained and retained as a public record by the Knox County Department of Code Administration.
- b. If any person is cited in violation of this article, a notation shall be included in such citation identifying with specificity where a copy of such code is located and the hours during which such person has the opportunity to read or inspect such code or document.

**SECTION 15. Knox County Code, Chapter 26, Article III entitled "Noise" is hereby repealed and deleted in its entirety.**

**SECTION 16. This Ordinance shall take effect as provided by the Charter of Knox County, Tennessee, the public welfare requiring it.**

  
\_\_\_\_\_  
Presiding Officer of the Commission      Date 11/19/18

  
\_\_\_\_\_  
County Clerk      Date 11/20/18

Approved:   
\_\_\_\_\_  
County Mayor      Date 11/25/18

Vetoed: \_\_\_\_\_  
County Mayor      Date

**Exhibit I**  
**Amendments to the 2018 International Building Code**

**Section [A] 101.1 Title.**

Delete “[NAME OF JURISDICTION]” and insert “Knox County, Tennessee” in its place.

**Section [A] 101.2.1 Appendices.**

Insert “The following Appendices are specifically included in the adoption. All others are excluded.

|            |  |
|------------|--|
| Appendix A | Employee Qualifications                  |
| Appendix B | Board of Appeals                         |
| Appendix C | Group U - Agricultural Buildings         |
| Appendix E | Supplementary Accessibility Requirements |
| Appendix F | Rodent Proofing                          |
| Appendix G | Flood-Resistant Construction             |
| Appendix H | Signs                                    |
| Appendix I | Patio Covers                             |
| Appendix J | Grading                                  |
| Appendix K | Administrative Provisions”               |

**Section [A] 101.4.3 Plumbing.**

Delete “*International Private Sewage Disposal Code*” and replace with “Knox County Health Department”.

**Section [A] 102.4.1 Conflicts.**

Between the words “code” and “and” insert “, 2018 NFPA 101,”. Delete “provisions of this code” and insert “most restrictive”.

**Section [A] 104.4 Inspections**

Add a new section as follows: “**Section 104.4.1 Re-inspections.** As deemed necessary by the code official, the owner/occupant of a facility found in violation of the adopted building codes and/or NFPA 101 shall contact the inspector responsible for identifying the building code and/or NFPA 101 violations to schedule the required re-inspection of the facility within the time frame specified by the inspector. The facility shall not be in compliance until all violations noted have been corrected and a re-inspection has been completed.”

**Section [A] 105.1 Required.**

Insert the words “or tenancy” after the word “occupancy”.

Insert a new section as follows:

**“[A] 105.1.3 Documentation prerequisite to issuance of a demolition permit.**

Before a permit for the demolition of any building may be issued the following documentation must be submitted:

1. Minimum three inch by five inch black and white photographs of all sides and any interesting details or features inside or outside of the structure and negatives of such photographs. Digital photographs shall be an acceptable alternate.
2. Any and all historical documents regarding the building that may be located by the applicant.
3. The completed historical and architectural information sheet describing the structure, including unusual features such as doors, trims, windows, mantles, stairways, decorative plaster, ceilings, etc.”

**Section [A] 110.3.3 Lowest floor elevation.**

At the end of the section insert "Compliance with the Knox County Department of Engineering and Public Works requirements regarding building in flood hazard areas shall be deemed to comply with this section."

**Section 202 Definitions**

After the definition for TECHNICAL PRODUCTION AREA, add a new definition as follows:  
TENANCY. Possession of real property under title or right.

**Section [A] 714.3 Installation details.**

Add a new section as follows: "Section 714.3.1 Installation requirements. The Knox County Fire Prevention Bureau Fire Stop Certificate of Completion form 714.3.1(1) or a functional equivalent must be completed by the fire-stopping installer prior to the issuance of a certificate of completion."

Insert a new form as follows:

**"Form 714.3.1(1)**

|   |   |                      |
|---|---|----------------------|
|  | KNOX COUNTY FIRE PREVENTION BUREAU<br>FIRE-STOP SYSTEM CERTIFICATE OF<br>COMPLETION |                      |
|   | PROJECT NAME: _____   | PERMIT NUMBER: _____ |
|   | ADDRESS: _____  | DATE: _____          |
|   | GENERAL CONTRACTOR: _____   |                      |

|  |  |  |  |  |  |
|--|--|--|--|--|--|
| LISTED AND TESTED FIRE STOP SYSTEMS SPECIFIED FOR THIS PRODUCT |  |  |  |  |  |
|--|--|--|--|--|--|

|            |          |           |            |                 |                            |
|------------|----------|-----------|------------|-----------------|----------------------------|
| ELECTRICAL | PLUMBING | SPRINKLER | MECHANICAL | ALARM<br>SYSTEM | CONSTRUCTION<br>GAP/JOINTS |
|------------|----------|-----------|------------|-----------------|----------------------------|



**Section [F] 907.2.10.1 Group R-1.**

Insert “4. In each garage or storage area with a six foot or wider door to the outside.”

**Section [F] 907.2.10.2 Groups R-2, R-3, R-4, and I-1**

Insert “4. In each private garage or storage area with a six foot or wider door to the outside.”

**Section 1004.5 Areas without fixed seating.**

Insert “*fire code official* or” just prior to “*building official*” in both occurrences.

**Section 1004.5.1 Increased occupant load.**

Insert “*fire code official* or” just prior to “*building official*” in both occurrences.

**Section 1004.7 Outdoor areas.**

Insert “*fire code official* or” just prior to “*building official*”.

**Section 1015.2 Where required.**

Delete the first sentence and replace with “Guards shall be located along open-sided walking surfaces or ground surfaces including mezzanines, equipment platforms, stairs, ramps, landings, retaining walls and any other locations that are located more than 30 inches (762 mm) measured vertically to the floor or grade below at any point within 36 inches (914 mm) horizontally to the edge of the open side.”

**Section 1030.2 Minimum size.**

Delete the Exception subsection in its entirety.

**Section 1612.3. Establishment of flood hazard areas.**

Delete the text of this section in its entirety and replace with “Flood hazard areas shall be determined in accordance with the regulations enforced by the Knox County Department of Engineering are public Works.”

**Section [P] 2901.1 Scope.**

Change “*International Private Sewage Disposal Code*” to “requirements of the Knox County Health Department”

Appendix B: Board of Appeals

Insert in the title the word “CONSTRUCTION” between the words “OF” and “APPEALS”.

**Section B101.2 Membership of the board.**

Delete the words “of appeals” in the first sentence.

Delete the words “chief appointing authority” and replace with the words “county legislative body” in the first sentence.

Insert “One for seven years; one for six years;” after the number “1’.

Delete the word “five” and replace with the word “seven” in item number 2.

Insert the words “and *fire code official*” after “*building official*” in the last sentence.

**Section B101.2.1 Alternate members.**

Delete Section B101.2.1 in its entirety.

**Section B101.2.2 Qualifications.**

Delete the words “of appeals” in the first sentence.

Delete the word “five” and replace with the word “seven” in the first sentence.

After the word “disciplines” insert “or as determined by the *building official* and the *fire code official*”

**Section B101.2.6 Secretary**

Delete the words “chief administrative officer” and replace with the words “building official” in the first and second sentences.

**Section B101.3.1 Open Hearing.**

Insert the words “, the *fire code official*” after “*building official*” in the last sentence.

**Section B101.3.3 Postponed Hearing.**

Delete the word “five” and replace with the word “seven”.

**Section B101.4 Board decision.**

Insert the words “and/or the *fire code official*” after “*building official*”.

Insert the word “majority” after the word “concurring” and delete “of two-thirds of its members”

**Section B101.4.1 Resolution.**

Insert the words “and *fire code official*” after “*building official*” in the last sentence.

**Section B101.4.2 Administration.**

Insert the words “and/or the *fire code official*” after “*building official*”.

**Section G102.2 Establishment or flood hazard areas.**

Delete “on [INSERT DATE]”

**Section H101.2 Signs exempt from permits.**

Delete Section H101.2 in its entirety.

**Section J101.1 Scope.**

Immediately after the word “chapter” insert “and the Knox County Department of Engineering and Public Works”

**Section K103.1 Exception:**

At the end of the section insert “Compliance with the State of Tennessee electrical inspectors permitting and inspection requirements shall be deemed to comply with the regulations contained herein.”

**Section K104.1 Information on construction documents.**

At the end of the section insert “Cover Sheet For Plans Submission form K104.1 shall be filled out.”

**Section K104.1 Cover Sheet For Plans Submission.**

Insert “

**Form K104.1  
COVER SHEET FOR PLANS SUBMISSIONS**

PROJECT NAME: \_\_\_\_\_

PROJECT ADDRESS: \_\_\_\_\_

PROJECT DESCRIPTION (Scope of Work): \_\_\_\_\_

FIRE DISTRICT: \_\_\_\_\_

PROJECT CONTACT PERSON: (Registered Arch. or Engineer in Responsible Charge)

ARCHITECTS/ENGINEERS/LANDSCAPE ARCHITECTS: List all names and pertinent information for each registrant (architect, engineers, and landscape architect) involved in the project. Include each engineering discipline represented in the project (civil, electrical, mechanical, plumbing, and structural).

Name \_\_\_\_\_

Company Name \_\_\_\_\_

Phone (including area code) \_\_\_\_\_ office \_\_\_\_\_ fax \_\_\_\_\_

E-Mail Address \_\_\_\_\_

Tennessee License Number \_\_\_\_\_

Design Codes/Edition \_\_\_\_\_

Accessibility Code Edition Used \_\_\_\_\_

Type of Construction \_\_\_\_\_

Occupancy Group(s) \_\_\_\_\_

Number of Stories (excluding basement unless educational or assembly occupancy) \_\_\_\_\_

Height of Building from Average Grade \_\_\_\_\_

Building Area Per Story \_\_\_\_\_ Existing \_\_\_\_\_ Proposed \_\_\_\_\_

Occupant Load Per Floor \_\_\_\_\_

Required Exit Width Per Floor \_\_\_\_\_

Number of Parking Spaces Required \_\_\_\_\_ Proposed \_\_\_\_\_ Handicapped \_\_\_\_\_ Van \_\_\_\_\_

Fire Protection hourly ratings for all structural components and separation of hazards components required by the applicable building code.

\_\_\_\_\_ Columns \_\_\_\_\_ Beams \_\_\_\_\_ Walls

\_\_\_\_\_ Floor/Ceiling \_\_\_\_\_ Roof/Ceiling \_\_\_\_\_ Roof Covering

\_\_\_\_\_ Corridors \_\_\_\_\_ Shaft Enclosures \_\_\_\_\_ Stair Enclosure

\_\_\_\_\_ Tenant Separations \_\_\_\_\_ Occupancy Separations

Sprinkler System Type : \_\_\_\_\_ Standpipe System : \_\_\_\_\_

Fire/Smoke Alarm System: \_\_\_\_\_

Abbreviations Used and Meaning: \_\_\_\_\_

**WATER SUPPLY DATA (FROM NEAREST HYDRANT TO SITE)**

Provide the following flow test data on the plans for hydrant(s) used to meet the 400 feet or less hose lay requirement in accordance with the Knox County Fire Prevention Bureau.

Show flow test data next to the hydrant tested. Flow test must have been conducted within the last six months from start of design process.

Static pressure \_\_\_\_\_ psi      Residual pressure \_\_\_\_\_ psi (20 psi minimum)

Flow \_\_\_\_\_ gpm (500 gpm minimum)

TN Department of Environment and Conservation Rules and Regulations 1200-5-1-17 paragraph 18.

Party responsible for taking test (name and address) \_\_\_\_\_

Date test taken: \_\_\_\_\_ Time test taken: \_\_\_\_\_ am/pm

Elevation of test hydrant: \_\_\_\_\_

**General Notes:**

- \*. Identify use of rooms and spaces
- \*. Show area increase calculations
- \*. Show wall ratings on structural, mechanical, plumbing, electrical, and fire protection drawings
- \*. Provide design live load values on plans for wind, snow, roof, floor, stairs, guard and hand railings, and seismic
- \*. Identify any exceptions/appeals/equivalencies and authority granting approval.”

**Section K106.1. General**

Delete the word “shall” and insert the word “may” in its place.

**Exhibit II**

**Amendments to the 2018 International Residential Code**

**Section R101.1 Title.**

Delete “[NAME OF JURISDICTION]” and insert “Knox County, Tennessee” in its place.

**Section R102.5 Appendices.**

At the end of this section, insert the following:

“The following Appendices are specifically included in the adoption. All others are excluded.

- Appendix A. Sizing and Capacities of Gas Piping
- Appendix B. Sizing of Venting Systems Serving Appliances Equipped with Draft Hoods, Category I Appliances and Appliances Listed For Use with Type B Vents
- Appendix C. Exit Terminals of Mechanical Draft and Direct-Vent Venting Systems
- Appendix D. Recommended Procedure for Safety Inspection of an Existing Appliance Installation
- Appendix E. Manufactured Housing Used as Dwellings
- Appendix F. Radon Control Methods

- Appendix G. Piping Standards for Various Applications
- Appendix H. Patio Covers
- Appendix J. Existing Buildings and Structures
- Appendix K. Sound Transmission
- Appendix M. Home Day Care - R-3 Occupancy
- Appendix N. Venting Methods
- Appendix O. Automatic Vehicular Gates
- Appendix P. Sizing of Water Piping Systems
- Appendix Q. Tiny Houses

Insert a new section as follows:

**“R105.1.1 Documentation prerequisite to issuance of a demolition permit.**

Before a permit for the demolition of any building may be issued the following documentation must be submitted:

1. Minimum three inch by five inch black and white photographs of all sides and any interesting details or features inside or outside of the structure and negatives of such photographs. Digital photographs shall be an acceptable alternate.
2. Any and all historical documents regarding the building that may be located by the applicant.
3. The completed historical and architectural information sheet describing the structure, including unusual features such as doors, windows, mantles, stairways, decorative plaster, ceiling, etc.”

**Section R105.2 Work exempt from permit.**

Delete Item 1 in its entirety.

Delete “2. Fences not over 7 feet (1829 mm) high.” and insert “2. Fences.” in its place.

**Section R106.1 Submittal documents.**

At the end of the first paragraph before the exception, insert “All construction documents, including the site plan, for all buildings over 5000 square feet in area and for all buildings with three or more attached dwellings shall be prepared and sealed by a registered design professional licensed by the State of Tennessee.”

**Table R301.2(1) Climatic and Geographic Design Criteria.**

Insert “10 PSF” in the table for Ground Snow Load.

Insert “90” in the table for Wind Speed.

Insert “No” in the table for topographic effects.

Insert “C” in the table for Seismic Design Category.

Insert “Severe” in the table for Weathering.

Insert “12 inches” in the table for Frost Line Depth.

Insert “Moderate to heavy” in the table for Termite.

Insert “19 degrees Fahrenheit” in the table for Winter Design Temperature.

Insert “No” in the table for Ice Barrier Underlayment Required.

Insert “210” in the table for Air Freezing Index.

Insert “59.4” in the table for Mean Annual Temperature.

Delete footnote g. in its entirety and in its place insert “g. Flood hazard areas shall be as determined by the Knox County Department of Engineering and Public Works.”

**Section R301.2.2 Seismic provisions.**

Delete item 1, renumber item 2 to item 1 and insert “and townhouses” just after the word dwellings and at the end of the section insert “All references to “townhouses in seismic design category C” in Chapters 6, 7, and 28 shall not apply in Knox County.”

**Section R302.5.1 Opening protection.**

After the words “fire-rated doors” replace the “,” with a ”.” and delete the remainder of the sentence.

**Section R303.4 Mechanical ventilation.**

Add the word “(Optional).” in the section title after the word ventilation.

Delete the words “the dwelling unit shall be provided with whole-house mechanical ventilation” and replace with the words “dwelling units provided with whole-house mechanical ventilation shall be”.

**Section R313 Automatic Fire Sprinkler Systems**

Add the words “(Optional, see Tennessee Code Annotated, Section 68-120-101(a)(8) ).” in the section title after the word “Systems”.

**Section R313.1 Townhouse automatic fire sprinkler systems.**

Delete the words “An automatic residential fire sprinkler system shall be installed in townhouses.” and replace with “When an automatic residential fire sprinkler system is installed in townhouses, the following shall apply:”

**Section R313.2 One- and two-family dwellings automatic fire sprinkler systems.**

Delete the words “An automatic residential fire sprinkler system shall be installed in one- and two-family dwellings.” and replace with “When an automatic residential fire sprinkler system is installed in one- and two-family dwellings, the following shall apply:”

**Section R314.3 Location.**

Insert “5. In each garage. These smoke alarms shall be specifically approved for use in the garages in the manufacturers written instructions. **Exception:** Heat detectors interconnected with the alarm system and having battery back up may be used in a garage.

**Section R322.1.7 Protection of water supply and sanitary sewage.**

Delete “and Chapter 3 of the *International Private Sewage Disposal Code*” and insert “, the requirements of the water and sewer service utility providers and the Knox County Health Department” in its place.

**Section R502.11.4 Truss Design Drawings.**

Delete “to the *building official* and *approved* prior to installation” and replace it with “for review when required by the *building official*”.

**Section R802.10.1 Truss design drawings.**

Delete “to the *building official* and *approved* prior to installation” and replace it with “for review when required by the *building official*”.

**Table N1102.1.2 (R402.1.2) Insulation and fenestration requirements by component.** In row Climate Zone 4 except marine under Ceiling R-Value delete “49” and replace with “38”. In the same row under Wood Frame Wall R-Value delete “20 or 13+5” and replace with “13”.

**Section N1102.2.6 (R402.2.6) Steel-frame ceilings, walls, and floors.**

After the first occurrence of the word “of” insert “Table N1102.1.2 or”.

**Section N1102.4.1.1 (R402.4.1.1) Installation.**

Add the words “ and visual inspection option.” after the word “Installation” in the section title.

Add the words “, and be field verified.” after the word “construction”.

**Section N1102.4.1.2 (R402.4.1.2) Testing.**

Add the word “(optional)” after the word “Testing” in the section title.

Before the first sentence insert “Where required by the *building official*,”

**Section N1103.1.1 (R403.1.1) Programmable thermostat.**

Add the word “(optional).” after the word “thermostat” in the section title.  
Before the first sentence insert “Where required by the *building official*,”

**Section N1103.2.2 (R403.2.2) Sealing (Mandatory).**

Before the word “Duct” insert “Where required by the *building official*,”

**Section N1103.6 (R403.6) Mechanical ventilation (Mandatory).**

Delete the word “Mandatory”. and replace with the word “Optional” in the section title.  
Delete “The building shall be provided with ventilation that meets” and replace with “Buildings provided with ventilation shall meet”.

**Section N1103.10 (R403.10) Pools and permanent spa energy consumption (Mandatory).**

Delete the word “Mandatory” and replace with the word “Optional” in the section title.  
Before the first sentence insert “Where required by the *building official*,”

**Section P2603.5.1 Sewer depth.**

Delete “[NUMBER]” in two places and insert “twelve inches” in two places.

**Section E3403.2 Inspection Required.**

Insert the words “where required” after the words “shall be inspected”.

**Section AE304.3.2.1 Investigation.**

Before the first sentence insert “Where required by the *building official*,”

**Section AE304.3.2.2 Fee.**

Before the first sentence insert “Where required by the *building official*,”

**Section AE305.5.1 Structural inspections for the manufactured home installation.**

At the end of the section insert “**Exception:** The inspections required by this section shall not apply to manufactured homes as exempted by the State of Tennessee but shall apply to any construction or installation of decks, porches, steps, or other structures or equipment. All manufactured homes shall pass a final inspection and have a certificate of occupancy issued.”

**Section AF103.5.3 Vent pipe.**

At the end of the section insert “**Exception:** The vent pipe shall be allowed to terminate in the attic and capped unless tests verify the radon potential to be 4 pCi/L or greater.”

**Section AF103.12 Power source.**

Delete Section AF103.12 in its entirety.

**Exhibit III**

**Amendments to the 2018 International Fuel Gas Code**

**Section [A] 101.1 Title.**

Delete “[NAME OF JURISDICTION]” and insert Knox County, Tennessee” in its place.

**Section [A] 101.3 Appendices.**

Insert “The following Appendices are specifically included in the adoption. All others are excluded.

- Appendix A. Sizing and Capacities of Gas Piping (IFGS)
- Appendix B. Sizing of Venting Systems Serving Appliances Equipped with Draft Hoods, Category I Appliances, and Appliances Listed for Use with Type B Vents (IFGS)
- Appendix C. Exit Terminals of Mechanical Draft and Direct-Vent Venting Systems (IFGS)
- Appendix D. Recommended Procedure for Safety Inspection of an Existing Appliance Installation (IFGS)”

**Section [A] 106.6.2 Fee schedule.**

Delete Section 106.6.2 in its entirety and insert “Fees as adopted by resolution for Knox County, Tennessee.”

**Section [A] 106.6.3 Fee refunds.**

Delete Section 106.6.3 in its entirety including the section number and title.

**Section [A] 108.4 Violation penalties.**

Delete “guilty of a [SPECIFY OFFENSE], punishable by a fine of not more than [AMOUNT] dollars or by imprisonment not exceeding [NUMBER OF DAYS], or both such fine and imprisonment” and insert “subject to penalties as prescribed by law” in its place.

**Section [A] 108.5 Stop work orders.**

Delete “liable for a fine of not less than [AMOUNT] dollars or more than [AMOUNT] dollars” and insert “subject to penalties as prescribed by law” in its place.

**Section 109 (IFGC) Means of Appeal.**

Delete section 109 in its entirety and insert “The Board of Construction Appeals shall be as established and regulated by the 2018 International Building Code.” in its place.

**Exhibit IV**

**Amendments to the 2018 International Property Maintenance Code**

**TABLE OF CONTENTS.**

Insert new chapters and subsections:

**“CHAPTER 9 LOT CLEANLINESS**

**Section**

**901 Declaration of Nuisance**

**902 Definitions**

**903 Lot Maintenance**

**904 Prohibited Acts**

**905 Presumption of Nuisance**

**906 Notice to Abate**

**907 Abatement by County**

**908 Penalties**

**909 Appeal**

**CHAPTER 10 ABANDONED AND INOPERABLE VEHICLES**

**Section**

- 1001 Declaration of Nuisance**
- 1002 Definitions**
- 1003 Exceptions**
- 1004 Abatement on Public Property**
- 1005 Abatement on Private Property**
- 1006 Disposition as Surplus**

**CHAPTER 11 VACANT, DETERIORATED OR BLIGHTED PROPERTIES**

**Section**

- 1101 Adoption of State Law**
- 1102 Definitions**
- 1103 Vacant Property Review Commission**
- 1104 Abatement Order**
- 1105 Eminent Domain**

**CHAPTER 12 NOISE**

**Section**

- 1201 Declaration of Nuisance**
- 1202 Definitions**
- 1203 Use Regulations**
- 1204 General Prohibitions**
- 1205 Exceptions**
- 1206 Noise Permits**
- 1207 Construction Chapter”**

**Section [A] 101.1 Title.**

Delete “[NAME OF JURISDICTION]” and insert in its place “Knox County, Tennessee”.

**Section [A] 101.2 Scope.**

Insert the word “, vehicles” after the word “equipment”.

**Section [A] 102.3 Application of other codes.**

Delete “*International Zoning Code.*” and insert in its place “adopted codes, ordinances, and resolutions of Knox County, Tennessee.”

**Section [A] 102.5 Workmanship.**

At the end of the section, insert “Residential Construction Performance Guidelines for Professional Builders & Remodelers, Third Edition as published by the National Association of Home Builders may be used as a performance guideline.”

**Section [A] 103.5 Fees.**

Delete [JURISDICTION TO INSERT APPROPRIATE SCHEDULE] and insert “Fees as adopted by resolution for Knox County, Tennessee.”

**Section [A] 106.3 Prosecution of Violations.**

Delete the first sentence of Section 106.3 and insert the following sentence in its place: Any person failing to comply with and an order served in compliance with this code shall be guilty of a violation of this code and subject to the penalties provided herein.

Insert a new section as follows:

**“Section [A] 110.5 Documentation prerequisite to issuance of permit.**

Before a permit for the demolition of any building may be issued the following documentation must be submitted:

1. Minimum three inch by five inch black and white photographs of all sides and any interesting details or features inside or outside of the structure and negatives of such photographs. Digital photographs shall be an acceptable alternate.
2. Any and all historical documents regarding the building that may be located by the applicant.
3. The completed historical and architectural information sheet describing the structure, including unusual features such as doors, windows, mantles, stairways, decorative plaster, ceiling, etc.”

**Section [A] 111.1 Application for Appeal.**

Delete Section 111.1 and insert the following in its place: “Unless a chapter of this code designates a specific administrative body to hear appeals and person directly affected by a decision of the *code official* shall have the right to appeal to the board of appeals, provided that a written application for appeal is filed with the *code official* within twenty (20) days of the day the decision, notice, or order was served. An application for appeal shall be based on a claim that the true intent of this code or the rules legally adopted thereunder have been incorrectly interpreted, the provisions of this code do not fully apply or the requirements of this code are adequately satisfied by other means. For the purpose of this section the “board of appeals” shall mean the Knox County Board of Zoning Appeals.

**Section [A] 111.2 Membership of the Board.**

Delete Section 111.2 in its entirety.

**Section [A] 111.4 Open hearing.**

Delete the last sentence of Section 111.4.

**Section [A] 111.4.1 Procedure.**

Delete the word “shall” in the first sentence of Section 111.4.1 and insert the word “may” in its place.

**Section [A] 112.4 Failure to comply.**

Delete “liable to a fine of not less than [AMOUNT] dollars or more than [AMOUNT] dollars” and insert “subject to penalties as prescribed by law” in its place.

**Section [A] 201.3 Terms defined in other codes.**

Delete “*International Zoning Code* or” and insert “or the adopted codes, ordinances, and resolutions of Knox County, Tennessee.” after “NFPA 70,”.

**Section 302.4 Weeds.**

Delete “[jurisdiction to insert height in inches]” and insert in its place “twelve inches”.

Add a new section as follows:

**“Section 303.3 Abandoned pools.**

All abandoned swimming pools shall be filled with concrete, dirt, or such other material as is necessary to prevent the accumulation of water within such abandoned pool. Any pool which is maintained or list in such condition as to demonstrate the intent of the owner that they are not to be in use for an indefinite period of time or a swimming pool not in use for a period of one year shall be presumed to be abandoned.”

**Section 304.14 Insect screens.**

Delete “During the period from [DATE] to [DATE],” and change “every” to “Every”.

**Section 602.3 Heat supply.**

Delete “during the period from [DATE] to [DATE]”

**Section 602.4 Occupiable work spaces.**

Delete “during the period from [DATE] to [DATE]”

**Chapter 8 Referenced Standards**

Delete “IZC-18 International Zoning Code .....102.3, 201.3”

At the end of the section insert “Residential Construction Performance Guidelines for Professional Builders & Remodelers, Third Edition as published by the National Association of Home Builders .....102.5.”

Insert new chapters 9, 10, 11, and 12 as follows:

**CHAPTER 9 LOT CLEANLINESS**

**Section 901. Declaration of Nuisance.** The existence of trees, vines, grass, underbrush or the accumulation of debris, trash, litter, garbage, or any combination of the preceding elements, or a vacant dilapidated building or structure, so as to endanger the health, safety or welfare of other citizens, or to encourage the infestation of rats and other harmful animals is a nuisance subject to abatement under this Chapter.

**Section 902. Definitions.** As used in this chapter, unless the context clearly indicates otherwise, the following terms shall have the following meanings:

1. *Dilapidated Building or Structure.* An unsecured, open, vacant building deemed unfit by a certified building inspector.
2. *Natural Landscaped Area.* Natural landscaping, also called native gardening, is the use of native plants, including trees, shrubs, ground cover, and grasses which are indigenous to the geographic area of the garden which is either naturally established or designed and cultivated that when established will sustain itself with minimal maintenance effort that do not contain noxious weeds or poisonous plants that cause a public nuisance.
3. *Subdivided Vacant Lots.* Any lot cleared and graded for future construction within a subdivision.

**Section 903. Lot Maintenance.** Subdivided lots must be mowed and maintained in their entirety if adjacent to homes. All others must have a ten (10) foot perimeter maintained at all times.

**Section 904. Prohibited Acts.** It shall be unlawful for any person owning, leasing, occupying or having control of property to:

1. Allow trees, vines, grass, weeds, underbrush or any other vegetation to grow or debris, trash, litter, garbage, refuse or other materials, a vacant dilapidated building or structure, or any combination of such elements to accumulate on such property to such an extent that a nuisance is created injurious to the health, safety, and welfare of the inhabitants of the county, or that infestation by rats or other harmful animals is encouraged; or
2. Allow trees, vines, grass, weeds, or any plant that is not cultivated to grow in rank profusion or otherwise in, along, upon or across the sidewalk or street adjacent to the premises in the area between the property line and the curb line, or within the area ten (10) feet beyond the property line, to a height greater than twelve (12) inches on an average.

**Section 905. Notice to Abate.** If the code official determines that a property is in violation of this Chapter, the code official shall notify the owner demanding abatement of the condition within ten days of receipt of the notice. In addition to the requirements of Section 107, the notice shall contain:

1. A brief statement of Tennessee Code Annotated 5-1-115, including the consequences of failing to remedy the noted condition;
2. The code official's name, office, address and telephone;
3. A cost estimate for remedying the noted condition, which shall conform with the standards of cost in the community; and
4. A place wherein the notified party may return a copy of the notice, indicating the desire for a hearing.

**Section 906. Penalties.** In the event the county is unable to remedy the condition creating a nuisance, the code official may assess penalties for violations of this Chapter as set forth in Section 106.4 of this Code.

**Section 907. Appeal.** Any person aggrieved by an order issued under this Chapter may appeal by filing a written application with the Board of Zoning Appeals within ten (10) days of receiving notice. The Board secretary shall place the matter on the Board's agenda for public hearing. At the public hearing, the Board may affirm, reverse, or modify the code official's order. Appeal from the decision of the Board shall be by certiorari.

## **CHAPTER 10 ABANDONED AND INOPERABLE VEHICLES**

**Section 1001. Declaration of Nuisance.** The presence within the county of an abandoned or inoperable motor vehicle on private or public property is a nuisance, which may be abated in accordance with the provisions of this chapter.

**Section 1002. Definitions.** As used in this chapter, unless the context clearly indicates otherwise, the following terms shall have the following meanings:

1. *Abandoned Motor Vehicle.* A motor vehicle that:
  - a) Is over four (4) years old and is left unattended on public property for more than ten (10) days;
  - b) Is in an obvious state of disrepair and is left unattended on public property for more than seventy-two (72) hours;
  - c) Has remained illegally on public property or within a public right of way for a period of more than forty-eight (48) hours;
  - d) Has remained on private property without the consent of the owner or person in control of the property for more than forty-eight (48) hours; or
  - e) Has been stored, parked or left in a garage, trailer park, or any type of storage or parking lot for more than thirty (30) consecutive days.
2. *Inoperable Vehicle.* A motor vehicle that:
  - a) Will not move under its own power;

- b) Does not meet the requirements for operation of motor vehicles on public roads;
- c) Is without one or more wheels or inflated tires; or
- d) Has more than one broken window.

3. *Motor Vehicle.* Any vehicle that is designed to be self-propelled.

**Section 1003. Exceptions.** This chapter shall not apply:

1. To any motor vehicle on private property which is not visible from the street or from other public or private property, if the motor vehicle is completely enclosed within a permanent or portable building consisting of four walls and a roof and which is in compliance with all gas, plumbing, electrical, zoning and mechanical codes, and with the building and fire codes as adopted by the county; or
2. To any motor vehicle held in connection with a business enterprise lawfully licensed by the county and properly operated in the appropriate zone pursuant to the the zoning ordinance of the county, if the storage or parking of such motor vehicle is necessary to the operation of such business enterprise.

**Section 1004. Abatement on Public Property.** The code official may abate any abandoned or inoperable motor vehicle located on public property by the following procedure:

1. Within three (3) business days after seizure of an abandoned or inoperable motor vehicle on public property, the code official shall verify ownership of the vehicle through the Tennessee Information Enforcement System (TIES) or the Tennessee Department of Motor Vehicles Title Registration Division. Within three (3) business days after receiving verification of ownership, the code official shall notify the last known registered owner of the vehicle and all lien holders of record by registered mail, return receipt requested.
2. The notice shall describe the year, make, model and serial number of the motor vehicle; set forth the location of the facility where the motor vehicle is being held; inform the owner and any lien holders of their right to reclaim the motor vehicle within ten (10) days after the date of the notice, upon payment of all towing, preservation and storage charges resulting from placing the vehicle in custody; and state that the failure of the owner or lien holders to exercise their right to reclaim the vehicle within the time provided shall be deemed a waiver by the owner and all lien holders of all right, title, and interest in the vehicle and consent to the sale of the abandoned, immobile, or unattended motor vehicle at a public auction.
3. In the event there is no response to the notice by registered mail provided for in this subsection, then there shall be notice by one publication in one newspaper of general circulation in the county. The notice shall be in a small display ad format, but one advertisement may contain multiple listings.
4. If the owner or lien holder fails to reclaim a motor vehicle, the code official may sell the vehicle at a public auction. The purchaser at auction shall receive a sales receipt from the code official. The code official may use sale proceeds for payment of the expenses of the auction, the costs of towing, preserving and storing the vehicle, and all notice and publication costs. Any remaining proceeds shall be held for the owner of the vehicle or entitled lien holder for forty-five (45) days, and shall then be deposited into the general fund.

**Section 1005. Abatement on Private Property.** The code official may abate any abandoned or inoperable motor vehicle, including but not limited to the one vehicle allowed by Knox County, located on private property by the following procedures:

1. Prior to the seizure of an abandoned or inoperable vehicle on private property, the code official shall notify the owner, lessee, occupant, or person having control of such property demanding removal of the vehicle(s) within thirty (30) days. The notice required by this subsection shall contain:
  - a) An identification of the vehicle(s) in violation of this chapter;
  - b) A statement of the process an aggrieved person may use to appeal the notice; and
  - c) A statement of the consequences for failing to remove the vehicle(s).
2. Any person aggrieved by the notice provided in this Subsection may appeal to the Board of Zoning Appeals by filing a written application for appeal with the Office of Code Administration. The Board may affirm, reverse, or modify the code official's determination. Any person aggrieved by the action of the Board may appeal the decision as provided by law in the cases of certiorari.
3. If an aggrieved person fails to remove the vehicle from the property or appeal to the Board of Zoning Appeals within thirty (30) days of service of the notice, the code official may remedy the condition and abate the nuisance by seizing the vehicle.
4. When the time for appeal provided in this subsection expires, the code official may sell the vehicle at a public auction according to the procedure of abating abandoned or inoperable vehicles on public property in the preceding section.

**Section 1006. Disposition as Surplus.** If an owner or lien holder fails to reclaim a seized vehicle as provided in this Chapter and the vehicle does not sell at public auction, the code official may dispose of the vehicle as surplus county property.

## **CHAPTER 11 VACANT, DETERIORATED OR BLIGHTED PROPERTIES**

**Section 1101. Adoption of State Law.** Blighted or deteriorated properties in this county create a need to exercise the authority contained in title 13, chapter 21, part 2 of the Tennessee Code Annotated governing the acquisition, holding, clearing, maintenance, and disposition of property determined to be blighted or deteriorated; therefore, Knox County adopts the provisions of said title, chapter, and part.

**Section 1102. Definitions.** As used in this chapter, unless the context clearly indicates otherwise, the following terms shall have the following meanings:

1. *Blighted or deteriorated property.* Any vacant structure or land, except property used for agricultural purposes, in a predominantly built-up neighborhood:
  - a) Which because of physical condition or use is regarded as a public nuisance at common law or has been declared a public nuisance in accordance with local housing, building, plumbing, fire or related codes;
  - b) Which because of physical condition, use or occupancy is considered an attractive nuisance to children, including, but not limited to, abandoned wells, shafts, basements, excavations, and unsafe fences or structures;
  - c) Which, because it is dilapidated, unsanitary, unsafe, vermin-infested or lacking in the facilities and equipment required by the housing code of the municipality, has been designated as unfit for human habitation by the code official;
  - d) Which is a fire hazard, or is otherwise dangerous to the safety of persons or property;

- e) From which the utilities, plumbing, heating, sewage or other facilities have been disconnected, destroyed, removed, or rendered ineffective so that the property is unfit for its intended use;
- f) Which by reason of neglect or lack of maintenance has become a place for accumulation of trash and debris, or a haven for rodents or other vermin;
- g) Which has been tax delinquent for a period of at least three (3) years; or
- h) Which has not been rehabilitated within the time constraints placed upon the owner by the code official.

2. *Residential, commercial, industrial and related use.* Residential or commercial or industrial property for sale, lease, or rent and related uses; such related uses include, but are not limited to, park and recreation areas, neighborhood community service, parking lots or structures, and any use which is consistent with or complementary to the existing properties in the area.

**Section 1103. Vacant Property Review Commission.** There is hereby established the county vacant property review commission for the purpose of reviewing properties alleged to be blighted and certifying them to the county commission for acquisition. The nine (9) duly appointed members of the board of zoning appeals shall also serve on the vacant property review commission. The county vacant property review commission shall meet after the monthly board of zoning appeals meeting as needed.

**Section 1104. Procedure.**

1. If the code official determines that a property is blighted or deteriorated, the official may order the owner or the owner's designated agent to eliminate the conditions that are a violation of law. The order shall state that the property is blighted or deteriorated and give a general description of the condition or conditions that constitute the blight or deterioration. The order shall demand elimination of the blight or deterioration within a definite time, not to exceed thirty (30) days. The order shall state that failure to eliminate the blight or deterioration within the provided time will result in referral of the matter to the vacant property review commission.
2. If an owner or designated agent fails to eliminate the blight or deterioration as ordered by the code official, the code official may refer the matter to the vacant property review commission. Contemporaneously with such referral, the code official shall request a planning commission determination that reuse of the property for residential, commercial, industrial and related use is consistent with the comprehensive plan.
3. Upon referral of a blighted or deteriorated property to the vacant property review commission, the commission secretary shall notify the owner or designated agent of the referral by certified mail, return receipt requested; however, if the address of the owner or designated representative is not reasonably ascertainable, the secretary shall post not in a conspicuous place on the property. The notice shall state that the code official referred the property to the commission as blighted or deteriorated and give a general description of the condition or conditions that constitute blight or deterioration. The notice shall demand elimination of the blight or deterioration within ninety (90) days. The notice shall contain a hearing date the coincides with a vacant property review commission meeting date following the expiration of the 90-day period. The vacant property review commission may grant an extension of time for good cause shown.
4. On the hearing date contained in the secretary's notice, the vacant property review commission shall hold a public hearing to determine whether to certify the matter to the county commission for eminent domain proceedings. The vacant property review commission may make such a certification upon finding:
  - a) that the code official ordered the owner or designated agent to eliminate the conditions which are in violation of local codes or law;
  - b) that the property is vacant;
  - c) that the property is blighted or deteriorated;

- d) that the commission secretary notified the property owner or designated agent that the property is blighted for deteriorated and the owner or designated agent failed to comply with the notice within the time provided; and
- e) the planning commission of the municipality has determined that reuse of the property for residential, commercial, industrial and related use is in keeping with the comprehensive plan.

**Section 1105. Eminent Domain.** Upon receipt of a blight or deterioration certification, the county commission may authorize eminent domain proceedings pursuant to title 29, chapters 16 and 17, if the county commission also finds that:

- 1. Such property has deteriorated to such an extent as to constitute a serious and growing menace to the public health, safety and welfare;
- 2. Such property is likely to continue to deteriorate unless corrected;
- 3. The continued deterioration of such property may contribute to the blighting or deterioration of the area immediately surrounding the property; and
- 4. The owner of such property has failed to correct the deterioration.

## CHAPTER 12 NOISE

**Section 1201. Declaration of Nuisance.** The county commission finds that excessive noise is detrimental to the physical, mental and social well being of the citizens of the county as well as to their comfort, living conditions, general welfare and safety and hereby declares it necessary to provide for more effective regulation of excessive noise. It is the intent of this chapter to establish standards that will eliminate or reduce unnecessary and excessive noise, which is physically harmful and otherwise detrimental to individuals and the community in the enjoyment of life, property and conduct of business.

**Section 1202. Definitions.** As used in this chapter, unless the context clearly indicates otherwise, the following terms shall have the following meanings:

- 1. *Ambient noise.* The all-encompassing noise associated with a given environment, being usually a composite of sounds from many sources near and far.
- 2. *A-weighted sound pressure level.* The sound pressure level in decibels as measured on a sound level meter using the A-weighting network, as defined in American National Standard SI.4-1983 (R 1997). The level so read is designated dB(A).
- 3. *City.* The city of Knoxville.
- 4. *County.* The Knox County.
- 5. *Commercial use.* The activity within or upon a premise where offices, clinics, kennels, shopping and service establishments exist and none of the gross floor area meets the definition of residential use, as set forth below.
- 6. *dB(A).* The sound level shown in a reading made on the dB(A) scale.
- 7. *Decibel (dB).* A unit for measuring the volume of a sound, equal to twenty (20) times the logarithm to the base ten of the ratio of the pressure of the sound measured to the reference pressure, which is twenty micropascals (twenty (20) micronewtons per square meter).
- 8. *Impulsive sound.* A sound of short duration, usually less than one second, with an abrupt onset and rapid decay. Examples of sources of impulsive sound include explosions, drop forge impacts, and the discharge of firearms.
- 9. *Industrial use.* Any activity within or upon a premise where manufacturing, processing or fabrication of goods or products takes place.

10. *Motor vehicle.* Any motor vehicle required to be registered by the department of safety for the state, pursuant to Title 55 of the Tennessee Code.
11. *Person.* Any individual, association, partnership, or corporation, and includes any officer or employee thereof.
12. *Public premise.* All real property, including appurtenances thereon, which is owned or controlled by any public governmental entity and shall include streets, alleys, parks and navigable waterways, but shall not include real property leased to any nongovernmental entity for residential, commercial or industrial use, as defined herein.
13. *Real property boundary.* A line along the ground surface, and its vertical extension, which separates the real property owned by one (1) person or entity from that owned by another person or entity, but not including intrabuilding real property divisions.
14. *Repair.* The restoration of a broken, damaged, or failed device, equipment, part, or property to an acceptable operating or usable condition or state.
15. *Residential use.* Any premises lawfully used for human habitation under county ordinances and the laws of the state and shall include schools, churches, hospitals, nursing homes, and similar institutional facilities. For purposes of this chapter only, premises adjoining, adjacent to or opposite hospitals or nursing homes shall also be deemed residential use.
16. *Sound pressure.* The average rate at which sound energy is transmitted through a unit area in a specific direction.
17. *Sound pressure level meter.* An instrument used for measurement of the intensity of sound and accurately calibrated in decibels. Readings shall be made on a dB(A) scale.

**Section 1203. Use Regulations.** No person within the county shall cause, suffer, allow or permit sound from any source which, when measured from the real property boundary of the source of the sound, is in excess of the following standards:

1. *Residential use.*
  - a. When the offending sound emanates from a residential use between the hours of 7:00 a.m. and 10:00 PM, sound which has an A-weighted sound pressure level of 65 dB(A), or impulsive sound which has an A-weighted sound pressure level of 80 dB(A).
  - b. When the offending sound emanates from a residential use between the hours of 10:00 PM and 7:00 a.m., sound which has an A-weighted sound pressure level of 60 dB(A), or impulsive sound which has an A-weighted sound pressure level of 80 dB(A).
2. *Commercial use.*
  - a. When the offending sound emanates from a commercial use between the hours of 7:00 a.m. and 10:00 PM, sound which has an A-weighted sound pressure level of 80 dB(A), or impulsive sound which has an A-weighted sound pressure level of 80 dB(A).
  - b. When the offending sound emanates from a commercial use between the hours of 10:00 PM and 7:00 a.m., sound which has an A-weighted sound pressure level of 75 dB(A), or impulsive sound which has an A-weighted sound pressure level of 80 dB(A).
3. *Industrial use.*

- a. When the offending sound emanates from an industrial use, continuous or impulsive sound which has an A-weighted sound pressure level of 80 dB(A).
- b. No person shall cause, suffer, allow or permit from any source within a public premise any airborne sound which, when measured from the source of the sound, has an A-weighted sound pressure level in excess of 65 dB(A), or any impulsive sound which has an A-weighted sound pressure level of 80 dB(A). This subsection shall not apply to legitimate government operations. Sound, whether continuous or impulsive, shall be measured at approximately five (5) feet above grade, using a slow meter response setting and using a windscreen when appropriate.

**Section 1204. General Prohibitions.** Consistent with other provisions of this chapter, and in addition thereto, it shall be unlawful for any person within the county to make, produce, cause, suffer, continue or allow to be produced or continued by human voice, machine, animal, or device, or any combination of same, any unreasonably loud, unusual or unnecessary noise which disturbs the peace and quiet of any neighborhood, or which causes discomfort or annoyance to any reasonable person of normal sensitivity residing in the area, or which otherwise injures or endangers the comfort, repose, health, peace, safety or welfare of others.

1. The standards which shall be considered in determining whether a violation of this section exists shall include, but shall not be limited to the following:
  - a. The frequency of the noise;
  - b. The intensity of the noise;
  - c. Whether the nature of the noise is usual or unusual;
  - d. Whether the origin of the noise is natural or unnatural;
  - e. The frequency and intensity of the ambient noise, if any;
  - f. The proximity of the noise to residential sleeping facilities;
  - g. The nature and land use of the area within which the noise emanates;
  - h. The population density of the inhabitation of the area within which the noise emanates;
  - i. The time of the day the noise occurs;
  - j. The duration of the noise; and
  - k. Whether the noise is recurrent, intermittent, or constant.
2. The following acts, among others, are declared to be unreasonably loud, unusual or unnecessary noises in violation of this chapter, even if the noises referred to do not violate the noise level standards set forth in section 1203.
  - a. *Horns and signaling devices on vehicles.* The sounding of any horn or signaling device on any automobile, motorcycle, bus or other vehicle while not in motion, except as a danger signal if another vehicle is approaching apparently out of control, or if in motion only as a danger signal after or as brakes are being applied and deceleration of the vehicle is intended; the creation by means of any such signaling device of any unreasonably loud or harsh sound; and the sounding of such device for an unnecessary and unreasonable period of time.
  - b. *Steam whistles.* The blowing of any steam whistle attached to any stationary boiler, except to give notice of the time to begin or stop work, or as a warning of fire or danger, or upon request of proper county authorities.

- c. *Exhausts.* The discharge into the open air of the exhaust of any steam engine, stationary internal combustion engine, motor vehicle or motorboat engine except through a muffler or other device which will effectively prevent loud or explosive noises therefrom.
- d. *Drums and other attention-attracting devices.* The use of any drum or other instrument or device for the purpose of attracting attention by creation of noise to any performance, show or sale.
- e. *Animals and birds.* The keeping of any animal or bird which, by frequent barking, howling, crying, singing or causing any other frequent or long-continued noise, disturbs the comfort and repose of any person in the vicinity.
- f. *Sound trucks.* The use or operation on or upon the public streets in the county or on driveways or throughways owned by or leased to Knoxville's community development corporation of any device known as a sound truck, or any loudspeaker, sound amplifier or other instrument of any kind or character which emits therefrom loud and raucous noises and is attached to and upon any vehicle operated or standing upon the county streets or on driveways or throughways owned by or leased to Knoxville's community development corporation.
- g. *Defect in vehicle or noisy load.* The use of any automobile, motorcycle, or other vehicle so out of repair or loaded in such a manner as to create loud or unnecessary grating, grinding, rattling or other noise.
- h. *Pneumatic devices.* The use of any mechanical devices operated by compressed air unless the noise created thereby is effectively muffled and reduced.

**Section 1205. Exceptions.** None of the terms or prohibitions contained in this chapter shall apply to or be enforced against:

- 1. Any vehicle of the county or a public utility while engaged in necessary public business.
- 2. Excavations or repairs of bridges, streets or highways by or on behalf of the city, the county or the state during the night, when the public welfare and convenience renders it impossible to perform such work during the day.
- 3. Emergency activities of the city, the county or the state and emergency activities of public utilities when they are seeking to provide electricity, water or other public utility services and the public health, safety or welfare is involved.
- 4. Any special event authorized pursuant to the law, rules and regulations of the county.
- 5. Excavation, construction, demolition, repair, paving or alteration of buildings or streets. This exception shall not apply to such excavation, construction, demolition, repair, paving or alteration of buildings or streets in a residential use between the hours of 6:00 p.m. and 7:00 a.m. except in case of urgent necessity in the interest of public health and safety, and then only with a permit from the building inspector. If the building inspector should determine that the public health and safety will not be impaired by the erection, demolition, alteration or repair of any building or the excavation of streets and highways between the hours of 6:00 p.m. and 7:00 a.m., and further determines that loss or inconvenience would result to any party in interest, permission may be granted for such work to be done between the hours of 6:00 p.m. and 7:00 a.m. upon application being made at the time the permit for the work is awarded or during the progress of the work.
- 6. Use of domestic power equipment (including but not limited to power lawn mowers, leaf blowers, trimmers, snowblowers, tillers, saws, sanders, drills or similar devices) between 8:00 a.m. and 9:00 p.m.

7. Attendant on-site noise connected with the actual performance of organized sporting events on school campuses and in publicly owned parks or facilities.
8. Warning devices on authorized emergency vehicles and on motor vehicles used for traffic safety purposes.
9. Amplified and unamplified bells and chimes on schools, public buildings and other places of assembly.
10. Use of motor vehicles for the collection or compacting of refuse, except that such vehicles shall not operate between 10:00 p.m. and 7:00 a.m. in a residential use.
11. Cleaning and maintenance of parking lots and access roadways held open to the public, but only when such activities are not feasible between 7:00 a.m. and 10:00 p.m.
12. Any aircraft in flight subject to federal law regarding noise control and any helicopter in the act of landing or taking off, if such landing or taking off is approved by the county or necessary for the protection of human life.
13. Air conditioning and refrigeration units appurtenant to a permanent structure, so long as the unit or any of its component parts is not so out of repair as to create loud or unnecessary grating, grinding, rattling or other noise.
14. Human sounds emanating from children twelve (12) years of age or under, including but not limited to speech and utterances of laughter, cries, and sounds associated with play.
15. Security alarms on structures or motor vehicles, except that such alarms must terminate operation within five (5) minutes after activation for continuous airborne sound and within fifteen (15) minutes for impulsive sound unless otherwise provided in this Code.

**Section 1206. Noise Permits.** The code official shall, upon proper application, grant special permits for limited exceptions from the provisions of this chapter.

1. Special noise permits shall be issued only for events occurring on Friday, Saturday or a federally recognized holiday, and shall be effective only between the hours of 7:00 a.m. and 10:00 p.m. Special noise permits shall be limited to a single day, and no more than two (2) permits shall be issued to any premises in any twelve-month period, regardless of any change in ownership of the premises.
2. Any person seeking a special noise permit pursuant to this section shall file an application with the code official, which application shall contain specific information regarding the nature of the event for which the permit is sought, including the anticipated duration of the event, the address of the premises for which the permit is sought, the name (and address, if different from the premises for which the permit is sought) of the person seeking the permit, an acknowledgment of responsibility of the applicant for any violations of this chapter resulting from noncompliance with the terms of the permit, and the signature of the applicant. Said application shall be filed no less than three (3) business days prior to the effective date of the permit.
3. Upon receipt of a properly executed and signed application, the code official shall issue a special noise permit to the applicant, which permit shall exempt the premises specified in the permit from the provisions of sections 1203, 1204 and 1205 of this chapter for the date specified in the permit, except that sound emitted from the premises shall in no way exceed the standards set forth in 1203 of this Chapter by more than 10 dB(A).
4. Noncompliance with any conditions of the permit or any of the provisions of this section shall invalidate the permit and subject the applicant and any other person on the premises to all provisions of this chapter.

5. The permit shall be displayed prominently on the premises covered by the permit.

**Section 1207. Construction of Chapter.** The provisions of this chapter are severable. If any provision of this chapter or its application to any person or circumstance is held invalid, such invalidity shall not affect other provisions or applications of this chapter which can be given effect without the invalid provisions or application. Nothing in this chapter shall be construed as negating or superseding any other county ordinance, unless otherwise specifically noted."

## Exhibit V

### Amendments to the 2018 International Mechanical Code

**Section [A] 101.1 Title.**

Delete "[NAME OF JURISDICTION]" and insert in its place "Knox County, Tennessee".

|  |            |                |                    |
|--|------------|----------------|--------------------|
| <b>Section</b>   | <b>[A]</b> | <b>101.2.1</b> | <b>Appendices.</b> |
| Insert "The following Appendices are specifically included in the adoption. All others are excluded.<br>Appendix A. Chimney Connector Pass-Throughs" |            |                |                    |

**Section [A] 106.5.2 Fee schedule.**

Delete Section 106.5.2 in its entirety and insert "Fees as adopted by resolution for Knox County, Tennessee."

**Section [A] 106.5.3 Fee refunds.**

Delete Section 106.5.3 in its entirety including the section number and title.

**Section [A] 108.4 Violation penalties.**

Delete "guilty of a [SPECIFY OFFENSE], punishable by a fine of not more than [AMOUNT] dollars or by imprisonment not exceeding [NUMBER OF DAYS], or both such fine and imprisonment" and insert "subject to penalties as prescribed by law" in its place.

**Section [A] 108.5 Stop work orders.**

Delete "liable for a fine of not less than [AMOUNT] dollars or more than [AMOUNT] dollars" and insert "subject to penalties as prescribed by law" in its place.

**Section 109 (IFGC) Means of Appeal.**

Delete section 109 in its entirety and insert "The Board of Construction Appeals shall be as established and regulated by the 2018 International Building Code." in its place.

## Exhibit VI

### Amendments to the 2018 International Plumbing Code

**Section [A] 101.1 Title.**

Delete "[NAME OF JURISDICTION]" and insert in its place "Knox County, Tennessee".

**Section [A] 101.2 Scope.**

At the end of the first paragraph insert "The following Appendices are specifically included in the adoption. All others are excluded.

- Appendix B. Rates of Rainfall for Various Cities
- Appendix C. Structural Safety
- Appendix D. Degree Day and Design Temperatures
- Appendix E. Sizing of Water Piping System”

**Section [A] 106.6.2 Fee schedule.**

Delete Section 106.6.2 in its entirety and insert “Fees as adopted by resolution for Knox County, Tennessee.”

**Section [A] 106.6.3 Fee refunds.**

Delete Section 106.6.3 in its entirety including the section number and title.

**Section [A] 108.4 Violation penalties.**

Delete “guilty of a [SPECIFY OFFENSE], punishable by a fine of not more than [AMOUNT] dollars or by imprisonment not exceeding [NUMBER OF DAYS], or both such fine and imprisonment” and insert “subject to penalties as prescribed by law” in its place.

**Section [A] 108.5 Stop work orders.**

Delete “liable for a fine of not less than [AMOUNT] dollars or more than [AMOUNT] dollars” and insert “subject to penalties as prescribed by law” in its place.

**Section 109 Means of Appeal.**

Delete section 109 in its entirety and insert “The Board of Construction Appeals shall be as established and regulated by the 2018 International Building Code.” in its place.

**Section 305.4.1 Sewer Depth.**

Delete “[NUMBER]” in two places and insert “twelve” in its place.

Delete “(mm)” in two places.

**Section 701.2 Sewer Required.**

Delete “that is in accordance with the *International Private Sewage Disposal Code*”.

**Section 903.1 Roof Extension.**

Delete “[NUMBER]” and insert “twelve” in its place.

Delete “(mm)”

**Section 1101.1 Scope.**

Insert “This shall be in addition to all regulations enforced by the Knox County Department of Engineering and Public Works.” at the end of the section.

## **Exhibit VII**

### **Amendments to the 2018 International Fire Code**

**Section [A] 101.1 Title.**

Delete “[NAME OF JURISDICTION]” and insert “Knox County, Tennessee” in its place.

**Section [A] 101.2.1 Appendices.**

Insert “The following Appendices are specifically included in the adoption. All others are excluded.

Appendix B Fire-Flow Requirements For Buildings

|            |   |
|------------|---|
| Appendix C | Fire HYDRANT Locations And Distribution |
| Appendix D | Fire Apparatus Access Roads             |
| Appendix E | hazard Categories                       |
| Appendix F | Hazard Ranking”                         |

**Section [A] 102.7.1 Conflicts**

Between “code” and “and” add “,NFPA 101,”  
 Change “provisions of this code” to “most restrictive provision”

**Section [A] 102.7.2 Provisions in referenced codes and standards.**

Insert “as approved by the *fire code official*” at the end of the sentence before the period.

**Section [A] General.**

At the end of the section insert “This department shall be known as the Knox County Fire Prevention Bureau.”

**Section 104.11.1 Barricades.**

Change “fire chief” to “*fire code official*”

**Section 104.11.2 Obstructing operations.**

Change “fire chief” to “*fire code official*”

**Section [A] 107.2 Inspections.**

Add a new section as follows: “**Section 107.5 Re-inspections.** As deemed necessary the the fire code official the owner/occupant of a facility found in violation of the adopted fire code and/or NFPA 101 shall contact the inspector responsible for identifying the fire code candor NFPA 101 violations to schedule the required re-inspection of the facility within the time frame specified by the inspector. The facility shall not be in compliance until all violations noted have been corrected and a re-inspection has been completed.”

**Section [A] 109.1 Board of appeals established.**

Insert after the last sentence “The Board of Construction Appeals shall be the same as established and regulated by the 2018 International Building Code.”

**Section [A] 110.4 Violation penalties.**

Delete “guilty of a [SPECIFY OFFENSE], punishable by a fine of not more than [AMOUNT] dollars or by imprisonment not exceeding [NUMBER OF DAYS], or both such fine and imprisonment” and insert “subject to penalties as prescribed by law” in its place.

**Section [A] 112.4 Failure to comply.**

Delete “liable for a fine of not less than [AMOUNT] dollars or more than [AMOUNT] dollars” and insert “subject to penalties as prescribed by law” in its place.

**Section 401.3.1 Fire events.**

Insert new section to read: “**Section 401.3.1.1 Other emergencies.** In the event of any other emergency to which the fire department will respond on a property, the owner or occupant shall immediately notify the fire department.”

**Section 503.1 Where required.**

Change 503.1.3 to 503.1.4 and

Insert new section as follows:

**“Section 503.1.4 Utility Access Driveways.**

Plans for utility access driveways shall be submitted per the following:

Plans submitted require both a plan view and a profile and sometimes a grading. Plan is needed as well. The plan view must show:

1. Stationing,
2. Radii of centerline horizontal curves,
3. Points of curvature and tangency of the horizontal curves,
4. Horizontal curves that tie the driveway to the roadway,
5. Width of the pavement,
6. Width of the easement, and
7. The turnaround area for fire apparatus.

The minimum width of pavement permitted is 16 feet. However, the portion of the driveway in the right-of-way must be 20 feet.

**Turning templates** are needed to show that the fire truck can make the necessary movements. The design vehicle is a BUS-40 as it is similar to the fire truck in that it has a 40 foot length and a 25 foot wheelbase. The turning templates should be applied on a separate plan view.

Dead end driveways in excess of 150 feet in length shall be provided with and approved area for turning around fire apparatus. For layouts and dimensions of the **turn around area**, Appendix D of the International Fire Code (IFC) may be used as a guideline.

The **profile** must show:

1. Stations,
2. Grades,
3. Vertical curves,
4. Points of vertical intersection of the grades, and
5. No grade shall exceed 15%.

The **typical cross section** of pavement to be provided meets the driveway requirements of what Knox County uses for business driveways on capital projects. The section is as follows:

1. A compacted sub grade with 4 inches of base (mineral aggregate type "A", grade "D"),
2. 1-3/4 inches binder (bituminous hot mix grade B-M), and
3. 1-1/4 inches topping (asphaltic concrete surfacing grade "D").

This cross-section provides 7 inches of material.

The need for a **grading plan** is decided on a case-by-case basis. The effects of stormwater runoff on the side slopes of the proposed access driveway may require curbs culverts, catch basins or road side swale. Once again the need for these items is decided on a case-by-case basis.

If a utility wishes to collocate on an existing structure that does not have vehicular accessed, then access must be provided and will need to meet the conditions listed above."

#### **Section 507.5 Fire hydrant systems.**

Change the. "6" at the end of the sentence to "7" and add a new section as follows: "**Section 507.5.7 Hydrant removal.** Fire hydrants required by this code or otherwise installed shall not be removed without approval of the fire code official."

#### **Section 507.5.1 Where required.**

Add a new section as follows: "**Section 507.5.1.2 Fire hydrants in residential areas.** Fire hydrants shall be available at a distance of not more than 600 feet to all new dwellings within new residential developments/subdivisions or a manufactured housing parks containing more than four dwellings. Two copies of a site utility plan and designs showing the layout of all underground main and all fire hydrant locations shall be submitted by the owner/developer for review by the fire code official. **Exception:** Dwellings or manufactured houses equipped with an automatic sprinkler system, installed and tested in accordance with NFPA 13D or 13 R."

#### **Section 507.5.4 Obstruction.**

At the end of the section insert "Fire hydrants shall be maintained unobstructed in accordance with Detail 507.5.5(1)."

**Section 507.5.5 Clear space around hydrants.**

At the end of the section, before the period, insert "by the fire code official. Fire hydrants shall be maintained unobstructed in accordance with Detail 507.5.5(1)."

Insert a new detail as follows:

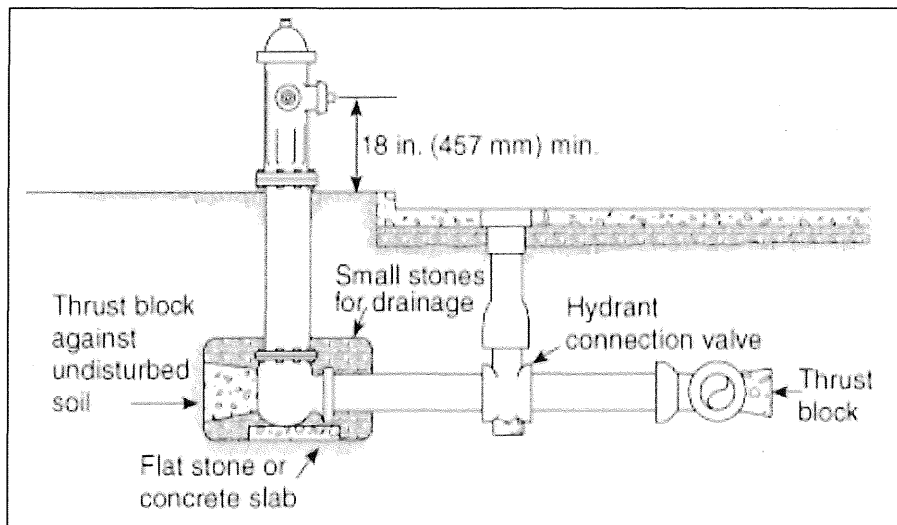
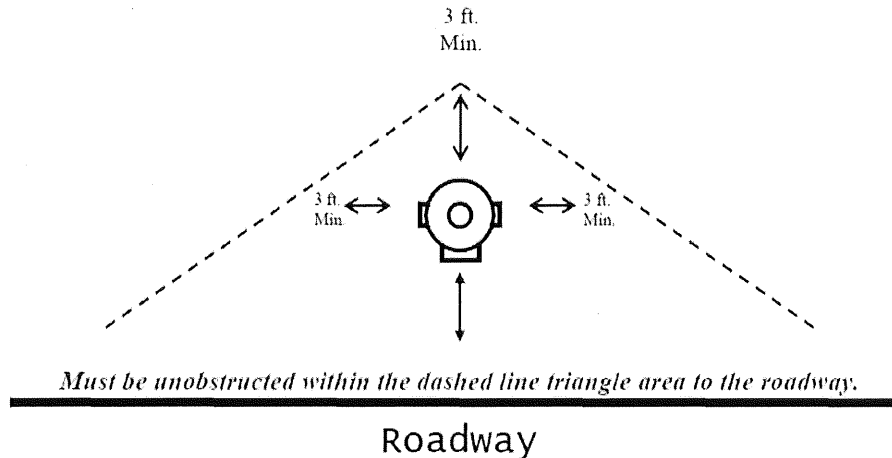

**“Detail 507.5.5(1)**

**Section 510 Emergency Responder Radio Coverage.**

Delete section 510 in it's entirety.

**Section 703.1 Maintaining protection.**

At the end of the section insert "The Knox County Fire Prevention bureau fire-stopping certificate of completion form 703.1(1) or a functional equivalent must be completed by the fire-stopping installer prior to the issuance of a certificate of completion."



**Section 901.6.3 Records.**

At the end of the section, add “All system records shall be submitted to the Knox County Fire Prevention Bureau within 10 days of any inspection, test, or maintenance.”.

**Section 901.7 Systems out of service.**

In the first sentence after “required” add “or otherwise installed”, and add a new section as follows:

“**Section 901.7.7 Fire protection system activation.** The activation or use of any fire protection system or device in connection with the control or extinguishment of a fire shall be reported to the *fire code official*. Such report shall be made by the owner and contractor of the premises in which the system or device is installed and by the contractor or service firm responsible for restoring the system dot normal operation or servicing the actuated system or unit. The owner or contractor shall report its use and performance as required by 901.7 to the fire code official immediately.”

**Section 903.2.8 Group R.**

At the end of the section add “Exception: this section shall not apply to detached one and two-family dwellings and multiple single family dwellings (townhouses) not more than three stories in height where each dwelling extends from the foundation to the roof, is open on at least two sides with each dwelling having separate means of egress and their accessory structures as regulated by the 2018 International residential Code.”

**Section 906.1 Where Required.**

Delete the Exception section under Section 906.1(1) in its entirety.

**Section 907.2.1.1 System initiation in Group A occupancies with an occupant load of 1,000 or more.**

Replace “1,000 or more” with “more than 300” in the title and in the code section.

**Section 907.2.10.2 Groups R-2, R-3, R-4 and I-1.**

Insert “4. In each garage or storage area with a six foot or wider door to the outside.”

**Section 907.6.6.1 Automatic telephone-dialing devices.**

Change “*fire chief*” to “*fire code official*”

**Section 912.2.1 Visible location.**

After the words “street side” add “(addressed side)”. At the end of the section add “The fire department connection shall be identified b a permanent approved sign which shall have the letters “FDC” at least 6” high in red on a white background.”

**Section 912.2 Location.**

Add a new section as follows: **Section 912.2.3 Hazards.** Gas meters, propane cylinders, electrical devices or any other product or device that could become a fire, explosion or electrical hazard shall be located a minimum of 15 feet from connections.”

**Section 912.4 Access.**

After the word “walls” insert “gas meters”.

**Section 912.4.2 Clear space around connections.**

Delete all after the word “required” and add “in section 912.2.3.”

**Section [B] 1030.2 Minimum size.**

Delete the Exception in its entirety.

**Chapter 11 Construction Requirements for Existing Buildings**

Delete Chapter 11 in its entirety.

**Section 5706.6.2.1 Parking near residential, educational and institutional occupancies and other high risk areas.**

Change “*fire chief*” to “*fire code official*”

**Section B104 Fire-Flow Calculation Area.**

Delete entire section.

**Section B105 Fire-Flow requirements For Buildings.**

Delete entire section.

**Table B105.1 Minimum Require Fire-Flow and Flow Duration For Buildings.**

Delete table.

**Section D103.1 Access road width with a hydrant.**

Delete Section D103.1, including the title and Figure D103.1, in its entirety, and replace with “**D103.1 Fire apparatus access roads.** All fire apparatus access roads shall meet or exceed the Knoxville-Knox County Minimum Subdivision Regulations.”

**Section D103.2 Grade.**

Delete Section D103.2 in its entirety.

**Section D103.3 Turning radius.**

Delete Section D103.3 in its entirety.

**Section D103.4 Dead ends.**

Delete Section D103.4, including Table D103.4, in its entirety.

**Section D103.5 Fire apparatus access road gates.**

Re-number Section D103.5 to D103.2

**Section D103.6 Signs.**

Delete Section D103.6, including Figure D103.6, in its entirety.

**Section D106.1 Projects having more than 100 dwelling units.**

Replace “100” with “125” where it appears in the title and in the section.

**Section D107 One- or Two-Family Residential Developments**

Delete Section D107 in its entirety.

**Exhibit VIII**

**Amendments to the 2018 NFPA 101 Life Safety Code**

**Section 1.2 Purpose.**

At the end of the section add “Exception: This Code shall not apply to detached one and two-family dwellings and multiple single family dwellings (townhouses) not more than three stories in height where each dwelling

extends from the foundation to the roof, is open on at least two sides with each dwelling having a separate means of egress and their accessory structures as regulated by the 2018 International Residential Code.”

### **Chapter 1 Administration.**

Insert a new section as follows: “**Section 1.7 Annexes.** Annex A, Explanatory Materials, is specifically included in the adoption.”

### **Section 3.3.36.3 Apartment Building.**

At the end of the section, add “Exception: Townhouses which are a group of three or more attached single-family dwelling units not more than three stories above grade in height in which each unit extends from foundation to roof and with open space on at least two sides with a separate means of egress and their accessory structures as defined by the 2018 International Residential Code shall not be considered as apartments for the purposes of this code.”

### **Section 4.7.1 Where required.**

Immediately after “shall be conducted as” insert “deemed necessary the the fire code official, and as”.

### **Section 4.7.6 Fire Drill Written Record.**

Immediately after the word “manner” insert “,and upon request a copy shall be provided to the fire code official”.

### **Section 6.1.14.1 General.**

Add a new section as follows: “**Section 6.1.14.1.4** All multiple occupancies of which at least one of the occupancies is of residential use, in which occupants sleep shall be equipped with a fire alarm detection system installed in accordance with LSC 9.6 and NFPA 72. Smoke or heat detection (depending on the areas to be protected and the use of the area) shall be installed in the following locations:

Residential area used for sleeping purposes:

1. Within all bedrooms or sleeping rooms.
2. Centrally located in a corridor or area giving access to each group of rooms used for sleeping purposes, and
3. On every level of the residential apartment.

Occupancies within the same building or structure:

1. Within all areas of all occupancies within the same building or structure spaced in accordance with NFPA 72.

Plans and designs shall be submitted for permit and review in accordance with IFC Section 907.1.1, to the Knox County Department of Codes administration and Inspections prior to installation. An acceptance test of the system master be approved by the fire inspector upon completion.”

### **Section 9.7.4.1**

Delete the test of this section in its entirety and replace with “Portable fire extinguishers shall be installed, inspected and maintained in all occupancies in accordance with NFPA 10, Standard for Portable Fire Extinguishers.”

### **Section 14.3.2.1(1)**

At the end of the subsection add the following: “(e) Laundries (equipped only with domestic equipment) and less than or equal to 100 square feet.”

### **Section 14.3.2.1(2)(a)**

After “Laundries” insert “greater than 100 square feet”

**Section 15.3.2.1(1)**

At the end of the subsection add the following: “(e) Laundries (equipped only with domestic equipment) and less than or equal to 100 square feet.”

**Section 15.3.2.1(2)(a)**

After “Laundries” insert “greater than 100 square feet”

**Section 16.1.1 Application.**

Add a new section as follows: “**Section 16.1.1.8** Unless otherwise required by three adopted codes of Knox County, Tennessee, all day care facilities (including adult day-care facilities) with seven or more persons shall be sprinklered with an NFPA 13 system.”

**Section 16.3.2.3**

Delete “or 16.3.2.5”

**Section 16.3.2.5**

Delete the text of this section in its entirety and replace with “Domestic cooking equipment capable of producing grease laden vapors shall be protected as required by NFPA 96.”

**Section 16.3.5.2**

Delete this section in its entirety.

**Section 16.6.3.5 Extinguishment Requirements.**

Delete this section in its entirety.

**Section 17.3.2.3**

Delete “or 17.3.2.5”

**Section 17.3.2.5**

Delete the text of this section in its entirety and replace with “Domestic cooking equipment capable of producing grease laden vapors shall be protected as required by NFPA 96.”

**Chapter 24 One- and Two-Family Dwellings.**

Delete Chapter 24 in its entirety.

**Section A.4.7.6 Fire Drill Written Record.**

Immediately after the word “paragraph” delete “should” and insert the word “shall “ in its place.

**Section A.24**

Delete all six section with the A.24 prefix in their entirety.

**Exhibit IX**

**Amendments to the 2018 International Code Council Performance Code**

**Section 102.3.6.3 Contract and peer review.**

At the end of the section insert “All costs for the required contract and peer reviews shall be the responsibility of the applicant.”

**Section 102.3.8.4 Technical opinion.**

At the end of the section insert “All costs for these services shall be the responsibility of the applicant.”

**Section 201.3 Terms not defined in other codes.**

Delete this section in its entirety and replace with the following:

“**Section 201.3 Terms defined in other codes.** Where terms are not defined in this code and are defined in other adopted codes such terms shall have the meanings ascribed to them as in those codes.”

**Section 201.4 Terms not defined.**

Insert a new section as follows:

“**Section 201.4 Terms not defined.**

Where terms are not defined through the methods authorized by this section, such terms shall have ordinarily accepted meanings such as the context implies.”

**Exhibit X**

**Amendments to the 2018 International Existing Building Code**

**Section [A] 101.1 Title.**

Delete “[NAME OF JURISDICTION]” and insert “Knox County, Tennessee” in its place.

**Section [A] 101.2 Scope.**

At the end of the section insert “The use of this code shall not exempt any portion of any existing building from any of the requirements of the 2018 NFPA 101 Life Safety Code.”

**Section [A] 101.4.1 Buildings not previously occupied.**

Immediately after “*International Building Code,*” insert “,the 2018 NFPA 101 Life Safety Code”

**Section [A] 101.4.2 Buildings previously occupied.**

Immediately after “*International Fire Code,*” insert “the 2018 NFPA 101 Life Safety Code,”

**Section [A] 101.6 Appendices.**

Insert “The following Appendices are specifically included in the adoption. All others are excluded.

Appendix A. Guidelines For The Seismic Retrofit Of Existing Buildings

Appendix B. Supplementary Accessibility Requirements For Existing Buildings and Structures”

**Section [A] 102.4 Referenced codes and standards.**

At the end of the section add “Exception: Where differences occur between provisions of this code and the 2018 NFPA 101 Life Safety Code, the code officials shall decide which shall apply.”

**Section [A] 103.1 Creation of enforcement agency.**

Insert “These departments shall be know as the Knox County Department of Codes Administration and Inspections and the Knox County Fire Prevention Bureau.” at the end of the section.

Insert a new section as follows:

“**Section [A] 105.1.3 Documentation prerequisite to issuance of permit.**

Before a permit for the demolition of any building may be issued the following documentation must be submitted:

1. Minimum three inch by five inch black and white photographs of all sides and any interesting details or features inside or outside of the structure and negatives of such photographs. Digital photographs shall be an acceptable alternate.
2. Any and all historical documents regarding the building that may be located by the applicant.
3. The completed historical and architectural information sheet describing the structure, including unusual features such as doors, trims, windows, mantles, stairways, decorative plaster, ceilings, etc.”

**Section [A]109.3 Required inspections.**

Delete this section in its entirety and replace with “When required by the code officials, the inspections set forth in this Sections 109.3.1 through 109.3.9 shall be subject to inspection by the code officials.”

**Section [A] 112 Board of Construction Appeals**

Delete this section in its entirety and insert “The Board of Construction Appeals shall be as established and regulated by the International Building Code.”

**Section 302.3 Additional codes.**

Delete “*International Private Sewage Disposal Code*” and insert “Knox County Health Department regulations” in its place and insert “2018 NFPA 101 Life Safety Code” just after “*International Residential Code*”

**Section 604.1 Scope.**

At the end of the sentence, before the period, insert “or as otherwise deemed necessary by the codes officials”

**Exhibit XI**

**Amendments to the 2018 International Energy Conservation Code**

**Section C101.1 Title.**

Delete “[NAME OF JURISDICTION]” and insert “Knox County, Tennessee” in its place.

**Section R101.1 Title.**

Delete “[NAME OF JURISDICTION]” and insert “Knox County, Tennessee” in its place.

**Section R101.5 Compliance.**

Just after the first occurrence of the word “provisions” insert “or Chapter 11, Energy Efficiency, of the International Residential Code”

**Section DC108.4 Failure to comply.**

Delete “liable to a fine of not less than [AMOUNT] dollars or more than [AMOUNT] dollars” and insert “subject to penalties as prescribed by law” in its place.

**Exhibit XII**

**Amendments to the 2018 International Swimming Pool and Spa Code**

**Section 101.1 Title.**

Delete “[NAME OF JURISDICTION]” and insert “Knox County, Tennessee” in its place.

**Section 105.2 Application for permit.**

At the end of the section insert “No swimming pool shall be permitted unless the swimming pool plans have been approved by the Knox County Health Department excluding private residential pool accessory to and on the same lot as a single family dwelling.”

**Schedule 105.6.2 Fee Schedule.**

Delete section 105.6.2 in its entirety and insert “Fees as adopted by resolution for Knox County, Tennessee.”

**Section 105.6.3 Fee refunds.**

Delete Section 105.6.3 in its entirety including the section number and title.

**Section 107.4 Violation Penalties.**

Delete “guilty of a [SPECIFY OFFENSE], punishable by a fine of not more than [AMOUNT] dollars or by imprisonment not exceeding [NUMBER OF DAYS], or both such fine and imprisonment” and insert “subject to penalties as prescribed by law” in its place.

**Section 107.5 Stop work orders.**

Delete “liable for a fine of not less than [AMOUNT] dollars or more than [AMOUNT] dollars” and insert “subject to penalties as prescribed by law” in its place.

**Section 108 Means of Appeal.**

Delete section 108 in its entirety and insert “The Board of Construction Appeals shall be as established and regulated by the 2018 International Building Code.” in its place.

**Section 305.2 Outdoor Swimming Pools and Spas.**

At the end of the section add two exceptions as follows:

- “1. All swimming pools in existence on May 20, 1991 which had an existing fence which is three feet or greater in height.
2. All swimming pools constructed prior to June 1, 1991 which are located on lots one acre in size or greater and located in either agricultural or estate zone.”

## **Exhibit XIII**

### **Amendments to the 2018 International Green Construction Code**

**Section [A] 101.1 Title.**

Delete “[NAME OF JURISDICTION]” and insert “Knox County, Tennessee” in its place.

**Section 101.3 Scope.**

Delete the word “apply” and insert “be optional and may be applied” in its place.

**Section 101.4 Appendices.**

Delete “Provisions in the appendices shall not apply unless specifically adopted.” and insert

Appendix A. Project Electives

Appendix B. Radon Mitigation

are specifically adopted. The provisions of the appendices shall be optional and may be applied to accomplish the scope and intent of the respective appendix.” in its place.

**Section 108.1 General.**

Insert "The Board of Construction Appeals shall be as established and regulated by the 2018 International Building Code." in its place.

**Table 302.1 Requirements Determined By the Jurisdiction.**

Insert "(Optional and may be applied)" after the word Jurisdictional Requirements in all the sections (20 places).